

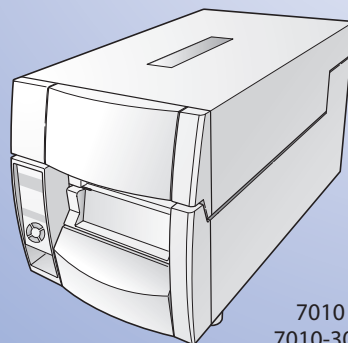

User Guide

7010 Thermal Printer



7010  
7010-300

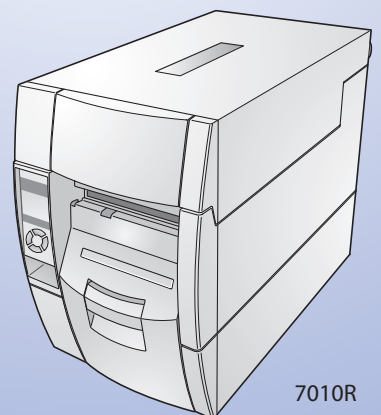

7010R

# CONTENTS

## Before Operation

INTRODUCTION	3
COMPLIANCE STATEMENT FOR EUROPEAN USERS	4
FCC COMPLIANCE STATEMENT FOR AMERICAN USERS	4
EMI COMPLIANCE STATEMENT FOR CANADIAN USERS	5
ETAT DE CONFORMITE EMI A L'USAGE DES UTILISATEURS CANADIENS	5
IMPORTANT SAFETY INSTRUCTIONS	6
NOTICE	7
SAFETY INSTRUCTIONS	8

## Chapter 1 Setup

Confirmation of Carton Contents	10
Part Names and Functions	11
Connection to Power	18
Driver Installation	18
Connection to a Computer	19

## Chapter 2 Printer Operation

Power ON/OFF	20
Normal Operating Mode	21
Setting the Media	23
Setting the Ribbon	32
Mode Settings	35
Quick Setup of the Print Method	51
Emulation Auto-Detection	52
Setting the menu for the Rewinder (7010R only)	53

## Chapter 3 Printer Adjustments

Sensor Adjustments and Calibration	54
Media Thickness Adjustment	57
Media Width Adjustment	58
Adjusting the Ribbon	59
Moving the Adjustable Sensor	61
Cleaning	62

## Chapter 4 Troubleshooting

### Appendixes

Specifications	66
Interfaces	70
Replacing the Interface Board	76
Replacing the Print Head	78

# INTRODUCTION

Thank you for purchasing a Tally Dascom-series label printer offering high performance printing at up to 10 inches per second on media up to 4.65 inches wide.

## /// **Main Features** ///

### **<Easy Access - Easy Operation>**

The printer is designed for all day-to-day operations to be accessible from the front of the printer so there is no need to move items near to the printer for access for media loading.

### **<Printer case>**

The main printer's case lifts directly upwards meaning that no space is needed on either side of the printer. The power switch is located in a recessed panel at the front of the printer so it can be easily accessed without moving the printer.

### **<The Easiest Media Loading>**

The metal print head mechanism opens so that it is completely clear of the media path so that the paper and ribbons can be loaded without any part of the printer in the way.

### **<Easy Printer Control and Configuration>**

The clear, easy-to-see backlit LCD makes both configuration and operation easy with simple messages about the printer's status and also the ability for quick configuration when needed.

### **<Flexible Media Usage>**

The printer features an adjustable media sensor which allows the customer to use any type of media. The media (label) rolls can be inside or outside wound. Similarly, the ink ribbon can be wound either way: 'ink in' or 'in out'.

### **<Optimum Ribbon Tension>**

The ribbon tensioning function - Active Ribbon Control and Positioning - maintains even ribbon tension from beginning to end of a ribbon. This eliminates ribbon wrinkle and improves print positioning, especially for small labels. Smudging caused by ribbon slippage is also removed.

### **<Dual Programming Language>**

This printer contains both the Datamax® and Zebra® emulations. By using the keys on the operation panel, it is easy to simply switch between the two emulations to meet your program.

### **<Interfaces and Options>**

Parallel, Serial and USB interfaces are supplied as standard and optional Ethernet and Wireless LAN boards can be fitted quickly and easily. An auto-cutter and peeler option is also available and can be easily installed.

### **<Easy Rewinder operation> (7010R only)**

The internal rewinder is easily accessed from the front of the printer and it can be used for winding liner or printed batches of labels.

## **COMPLIANCE STATEMENT FOR EUROPEAN USERS**

CE marking shows conformity to the following criteria and provisions:

Low Voltage Directive (2006/95/EC)/EN60950-1

EMC Directive (2004/108/EC)/EN55022, EN55024, EN61000-3-2 & EN61000-3-3

This product has been tested under EN ISO 7779 and has an acoustic level output no higher than 55db(A).

This device is not intended for use at a video workstation in compliance with Bildscharb V.

## **FCC COMPLIANCE STATEMENT FOR AMERICAN USERS**

This equipment has been tested and found to comply with the limits for a Class A digital device, pursuant to Part 15 of the FCC Rules. These limits are designed to provide reasonable protection against harmful interference when the equipment is operated in a commercial environment. This equipment generates, uses, and can radiate radio frequency energy and, if not installed and used in accordance with the instruction manual, may cause harmful interference to radio communications. Operation of this equipment in a residential area is likely to cause harmful interference in which case the user will be required to correct the interference at his own expense.

# EMI COMPLIANCE STATEMENT FOR CANADIAN USERS

**This Class A digital apparatus complies with Canadian ICES-003.**

This equipment generates and uses radio frequency energy and if not installed and used properly, that is, in strict accordance with the manufacturer's instructions, may cause interference to radio and television reception. This digital apparatus does not exceed the Class A limits for radio noise emissions from digital apparatus set out in the Radio Interference Regulations of the Canadian Department of Communications. This equipment is designed to provide reasonable protection against such interference in a residential installation. However, there is no guarantee that interference will not occur in a particular installation. If this equipment does cause interference to radio or television reception, which can be determined by turning the equipment off and on, the user is encouraged to try to correct the interference by one or more of the following measures:

- Reorient or relocate the receiving antenna.
- Increase the separation between the equipment and receiver.
- Connect the equipment into an outlet on a circuit different from that to which the receiver is connected.
- Consult the dealer or an experienced radio/TV technician for help.

**CAUTION:** Use shielded cables to connect this device to computers.

Any changes or modifications not expressly approved by the grantee of this device could void the user's authority to operate the equipment.

## ETAT DE CONFORMITE EMI A L'USAGE DES UTILISATEURS CANADIENS

**Cet appareil numérique de la classe A est conforme à la norme NMB-003 du Canada.**

Cet équipement produit et utilise l'énergie à radiofréquences et s'il n'est pas installé et utilisé correctement, c'est à dire en accord strict avec les instructions du fabricant, il risque de provoquer des interférences avec la réception de la radio et de la télévision.

Le présent appareil numérique n'émet pas de bruits radio électriques dépassant les limites applicables aux appareils numériques de la classe A prescrites dans le Règlement sur le brouillage radioélectrique édicté par le ministère des Communications du Canada.

Cet équipement est conçu pour fournir une protection satisfaisante contre de telles interférences dans une installation résidentielle. Cependant, il n'y a pas de garantie contre les interférences avec les réceptions radio ou télévision, provoquées par la mise en et hors circuit de l'équipement; aussi, il est demandé à l'utilisateur d'essayer de corriger l'interférence par l'une ou plus des mesures suivantes:

- Réorienter l'antenne de réception.
- Installer l'ordinateur ailleurs, par exemple pour le récepteur.
- Brancher l'ordinateur dans une prise de courant différente de façon à ce que l'ordinateur et le récepteur soient branchés sur des circuits différents.

# IMPORTANT SAFETY INSTRUCTIONS

- Read all of these instructions and save them for later reference.
- Follow all warnings and instructions marked on the product.
- Unplug this product from the wall outlet before cleaning. Do not use liquid or aerosol cleaners. Use a damp cloth for cleaning.
- Do not use this product near water.
- Do not place this product on an unstable cart, stand or table. The product may fall, causing serious damage to the product.
- Slots and openings on the cabinet and the back or bottom are provided for ventilation. To ensure reliable operation of the product and to protect it from overheating, do not block or cover these openings. The openings should never be blocked by placing the product on a bed, sofa, rug or other similar surface. This product should never be placed near or over a radiator or heat register. This product should not be placed in a built-in installation unless proper ventilation is provided.
- This product should be operated from the type of power source indicated on the marking label. If you are not sure of the type of power available, consult your dealer or local power company.
- This product is equipped with a three-pronged plug, a plug having a third (grounding) pin. This plug will only fit into a grounding-type power outlet. This is a safety feature. If you are unable to insert the plug into the outlet, contact your electrician to replace your obsolete outlet. Do not defeat the safety purpose of the grounding-type plug.
- Do not allow anything to rest on the power cord. Do not locate this product where the cord will be walked on.
- If an extension cord is used with this product, make sure that the total of the ampere ratings on the products plugged into the extension cord do not exceed the extension cord ampere rating. Also, make sure that the total of all products plugged into the wall outlet does not exceed 15 amperes for 120V outlet and 7.5 amperes for 220V-240V outlet.
- Never push objects of any kind into this product through cabinet slots as they may touch dangerous voltage points or short out parts that could result in a risk of fire or electric shock. Never spill liquid of any kind on the product.
- Except as explained elsewhere in this manual, don't attempt to service this product yourself. Opening and removing those covers that are marked "Do Not Remove" may expose you to dangerous voltage points or other risks. Refer all servicing on those compartments to service personnel.
- The mains plug on this equipment must be used to disconnect mains power. Please ensure that the socket outlet is installed near the equipment and shall be easily accessible.
- Unplug this product from the wall outlet and refer servicing to qualified service personnel under the following conditions:
  - A. When the power cord or plug is damaged or frayed.
  - B. If liquid has been spilled into the product.
  - C. If the product has been exposed to rain or water.
  - D. If the product does not operate normally when the operating instructions are followed. Adjust only those controls that are covered by the operating instructions since improper adjustment of other controls may result in damage and will often require extensive work by a qualified technician to restore the product to normal operation.
  - E. If the product has been dropped or the cabinet has been damaged.
  - F. If the product exhibits a distinct change in performance, indicating a need for service.



# NOTICE

- Before use, be sure to read this manual. And keep it handy for reference when needed.
- The contents of this manual may change without prior notice.
- Reproduction, transfer, or transmission of the contents of this manual without prior consent is strictly prohibited.
- We are not liable for any damage resulting from the use of the information contained herein, regardless of errors, omissions, or misprints.
- We are not liable for any problems resulting from the use of optional products and consumable supplies other than the designated products contained herein.
- Do not handle, disassemble or repair the parts other than those specified in this manual.
- We are not liable for any damage caused by user's erroneous use of the printer and inadequate environment.
- Data residing in the printer is temporary. Therefore, all data will be lost if power is lost. We are not liable for any damage or loss of profits caused by data loss due to failures, repairs, inspections, etc.
- Please contact us if there are any mistakes or ambiguities within this manual.
- If there are missing or incorrectly collated pages in this manual, contact us to obtain a new manual.

# SAFETY INSTRUCTIONS

## which must be strictly observed !

- To prevent personal injury or property damage, the following shall be strictly observed.
- The degree of possible injury and damage due to incorrect use or improperly following instructions is described below.

 <b>Warning</b>	Indicates a situation which, if not observed and handled properly, could result in death or serious injury.
 <b>Caution</b>	Indicates a situation which, if not observed and handled properly, could result in injury.



: This is a mark to call attention to the reader.

### **Warning**

Never perform the following. If not avoided, these may cause damage or trouble to the printer or cause the printer to overheat and release smoke and cause burns or an electrical shock. If the printer is damaged or is malfunctioning, be sure to turn the printer off immediately and remove the power cord from the outlet, then consult our service personnel.

- Do not place the printer in a poorly ventilated area, or shut off the air vent of the printer.
- Do not place the printer where chemical reactions occur, such as in laboratories or where air is mixed with salt or gas.
- Do not use a power voltage or frequency other than those specified.
- Do not plug/unplug the power cord or attach/detach the interface cable by simply grabbing the power cord or interface cable. Do not pull or carry the printer when the tension of the power cord or interface cable is increased.
- Do not drop or put foreign matter such as clips and pins into the printer. This may cause problems.
- Do not plug the power cord into an outlet with many loads.
- Do not spill drinks such as tea, coffee and juice on the printer or spray insecticide on the printer. If drink or water is spilled, first be sure to turn the power off and remove the power cord from the outlet, then consult our service personnel.
- Do not disassemble or modify the printer.

Discard or safely store the plastic packing bag. This bag should be kept away from children. If the bag is pulled over a child's head, it may cause suffocation.



## General Precautions

### **Caution**

- Prior to operation, read the safety instructions carefully and observe them.
- Do not drop or put foreign matter such as clips and pins into the printer. This may cause problems.
- Be careful when moving or carrying the printer. Dropping the printer may cause injury or property damage.
- Make sure if you open the top cover, it is opened all the way. If only partially open, the cover could slam shut, possibly causing injury.
- When the cover is open, be careful of the corners of the cover. They could cause injury.
- Do not open the printer during printing.
- When cleaning the surface of the printer case, do not use the cloth that is soaked in thinner, trichloroethylene, benzene, ketone or similar chemicals.
- Do not use the printer where there is a lot of oil, iron particles, or dust.
- Do not spill liquids or spray insecticide on the printer.
- Do not jolt or impact to the printer by stepping on, dropping or hitting the printer.
- Operate the control panel properly. A careless, rough handling may cause problems or malfunction. Do not use such sharp-edged tool as a ballpoint pen for operation.
- Be careful of the edges of the plates so injury or property damage is possible.
- If a problem occurs during printing, stop the printer immediately and unplug the power cord from the outlet.
- When printer trouble occurs, do not try to disassemble it. Instead, consult our service personnel.

## Precautions When Installing the Printer

### **Caution**

- Prior to operation, read the safety instructions carefully and observe them.
- Do not use or store the printer near fire, excessive moisture, in direct sunlight, near an air conditioner or heater or other source of unusually high or low temperature or humidity or excessive dust.
- Do not place the printer where chemical reactions occur, such as in a laboratory.
- Do not place the printer where air is mixed with salt or gas.
- The printer must sit on a firm, level surface where there is ample ventilation. Never allow the printer's air vent to be blocked by a wall or other object.
- Do not put anything on the top of printer.
- Do not place the printer near a radio or television, and do not use the same wall outlet for the printer and radio or television. Radio or television reception could be adversely affected.
- Use the power cord supplied with the product. Never use the power cord for other product.
- Do not put anything on the power cord or step on it.
- Do not drag or carry the printer with the power cord or interface cable.
- Avoid plugging the power cord into an outlet with many loads.
- Do not bundle the power cord when inserting the plug.
- Always grip the plug housing, not the cord, to plug/unplug the power cord.
- Make certain the power is turned off before connecting/disconnecting the interface cable.
- Avoid lengthening the signal cable or connecting it to any noise-producing device. If it is unavoidable, use the shielded cable or twisted pair for each signal.
- Place the printer near the outlet where the power cord can be unplugged easily to shut off power.
- Use the AC outlet that accepts a three-pronged plug. Otherwise, static electricity may be generated and there will be danger of electric shock.

## Confirmation of Carton Contents

### Removing the Packing Material

The printer is shipped with adhesive tape in place to hold the top cover closed. Simply remove the two pieces of tape on either side of the top cover. Then simply open the cover by lifting up and tipping it backwards.

There is another strip of adhesive tape that must be removed which holds the mechanism closed for shipping. Remove the tape and attached paper by carefully peeling from the plastic case.

Retain the tape should you need to transport the printer again. A further piece of packing paper is inside the mechanism and you can remove this when the head is opened as explained later in the manual.

Check that the following accessories are included with the printer in the carton.

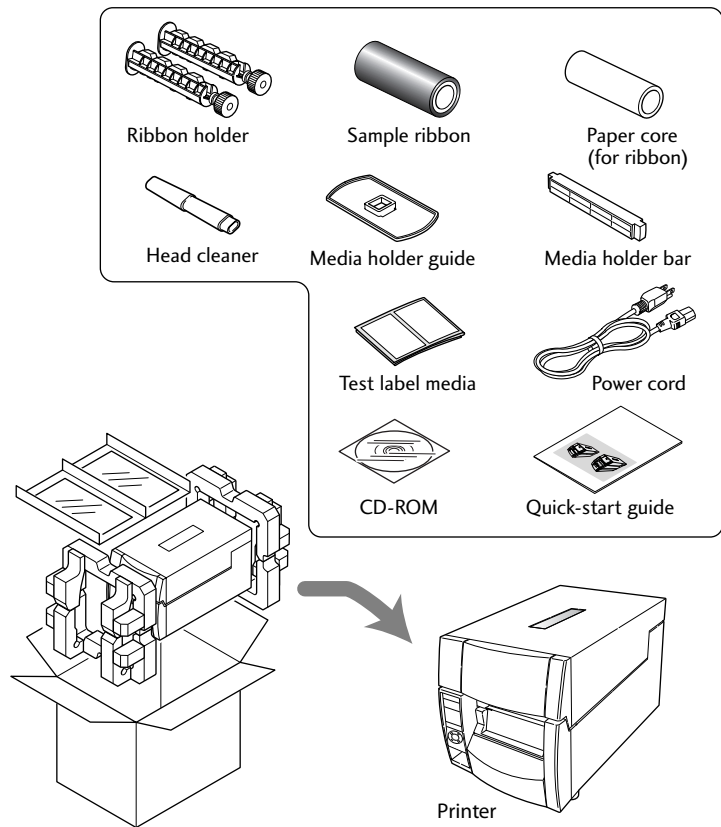

**Note:** The empty carton and packing materials should be stored for future shipping of the printer.

When removing the printer from the box, there is the extra cardboard "sling" to make lifting easier.

## ⚠ Caution

- Be careful when moving or carrying the printer and when taking the printer out of the carton. The printer may cause injury or property damage if dropped. Be sure to grip the printer housing firmly when taking it out of the carton. Do not grip the printer by the foam packing material which may break, causing the printer to drop.
- When opening the cover, open it all the way. If only part way open, the cover could slam shut, possibly causing injury.
- Be careful of the edge of the cover when the cover is opened. It may cause injury or property damage.
- Be careful of the edges of the metal plates as injury or property damage is possible.

## Part Names and Functions

### Inside the printer

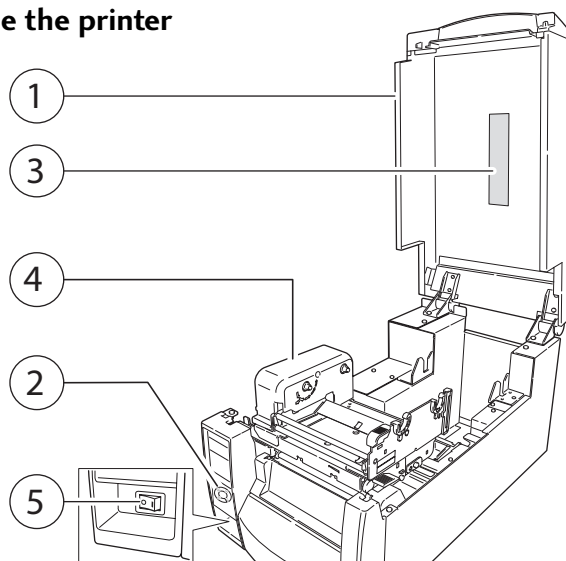

- ① **Top cover**  
Is opened vertically to set media or ribbon.
- ② **Operation panel**  
This is used to make changes and adjustments to the printer and its configuration.
- ③ **Top cover window**  
The amount of ribbon and media remaining can be checked through this window.
- ④ **Ribbon drive unit**
- ⑤ **Power switch**  
This is the power switch for the printer.

*Operation Panel (p.16)*

*Setting the Ribbon (p.32)*

*Power ON/OFF (p.20)*

## Part Names and Functions

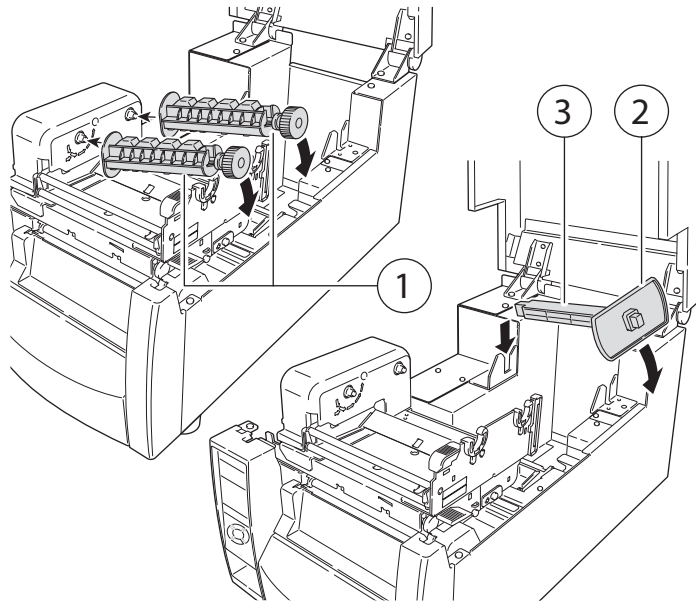

① **Ribbon holder**

It is used to attach the ribbon and paper core.

② **Media holder guide**

This guide is moved horizontally to match the media size.  
The guide can be sliding it from the holder bar.

③ **Media holder bar**

The media is supported by the media holder bar when installed in the printer.

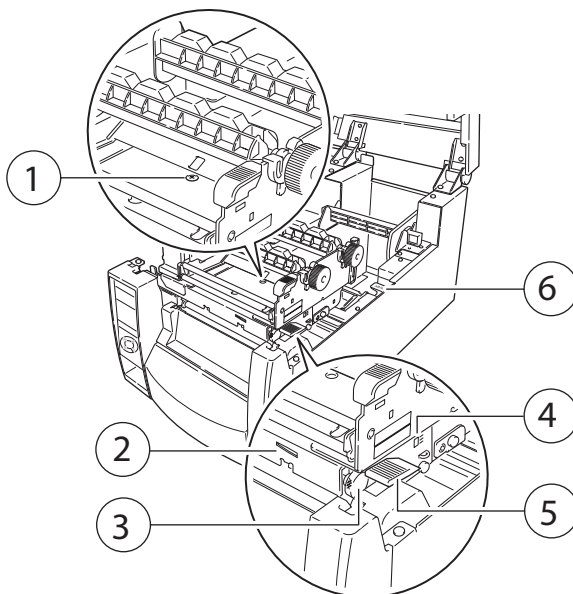

*Media Thickness Adjustment*  
(p.57)

*Media Width Adjustment*  
(p.58)

- ① **Media thickness adjustment screw**  
It is adjusted to match the thickness of the media.
- ② **Media width adjustment indicator**
- ③ **Media width adjustment knob**  
It is adjusted to match the width of the media.
- ④ **Media thickness adjustment indicator**
- ⑤ **Head open lever**  
The head unit can be raised to install media by pushing this lever.  
It locks the head unit during printing.
- ⑥ **Sensor arm open lever**  
The sensor arm can be raised to install media by pushing this lever.

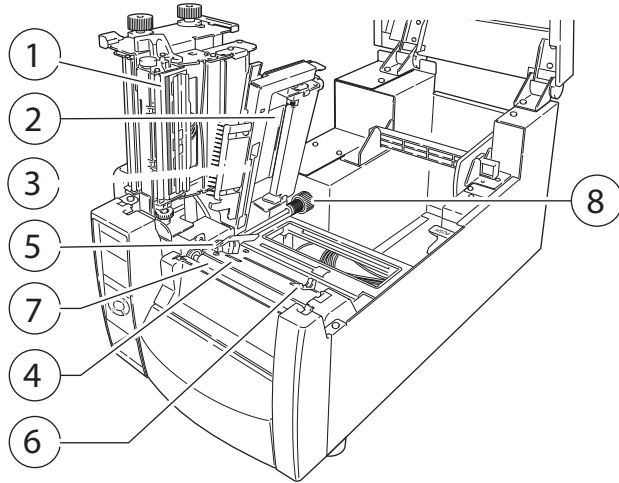

*Sensor Adjustments and Calibration (p.54)*

*Installing the Media (p.26, p33)*

- ① **Thermal printhead**  
This is the printhead. Avoid touching this with your fingertips and leaving grease or dirt on the printhead surface.
- ② **Sensor arm**  
The media can be installed by raising this arm.  
The media can be held in place by lowering this arm.
- ③ **Adjustable (rear) sensor**  
Detects the label or tag position. This sensor is switched “on” by default.
- ④ **Fixed media sensor**  
Alternative method to detect the label or tag position. This sensor is more accurate for small labels as it is closer to the print head. It is switched “off” by default.
- ⑤ **Left media guide**  
This is a fixed part of the printer. The left side of the media (labels, tags) as viewed from the front of the printer should be placed against this media guide.
- ⑥ **Right, movable media guide**  
Slide the right media guide so that it just touches the media. It should “guide” the media through the printer. It should **not hold it firmly** otherwise the media will jam.
- ⑦ **Platen**  
Interlocked with the thermal printhead, it feeds media backwards or forwards.
- ⑧ **Adjustable sensor position knob**  
This is used to change the left-to-right position of the adjustable media sensor across the media. See Chapter 3, Printer Adjustments for more details.

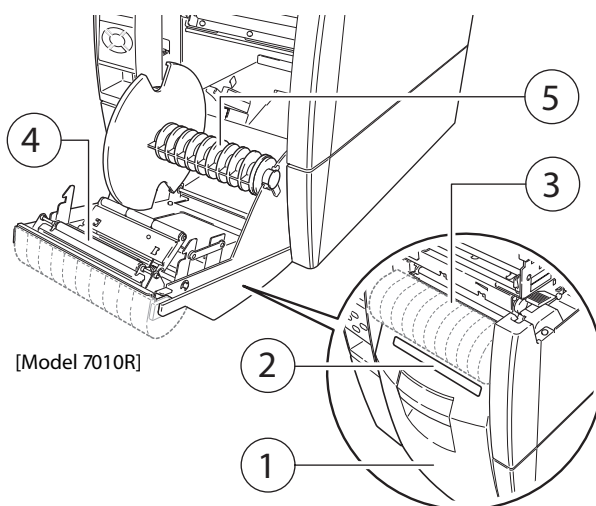

- ① **Rewinder cover**  
When using the rewinder function, open the door by pulling the opening handle on the front.
- ② **Media entry slit cover**  
When rewinding the printed batches of media, remove the Media Entry Slit Cover and insert the media from the head unit through the slit. It should then be rewound around the Rewinder Flange.
- ③ **Rewinder paper guide (available as an option from your supplier)**  
When the printer is being used in Peel mode, this curved guide is not needed. In batch mode, when rewinding printed media, this curved guide must be installed to guide the media through the media slit.
- ④ **Peeler rollers**  
The peeler rollers provide the pressure on the liner to cause the printer to peel off labels one-by-one.
- ⑤ **Rewinder flange**  
The liner or batches of printed media are wrapped around the central core of the rewinder flange.

## Operation Panel

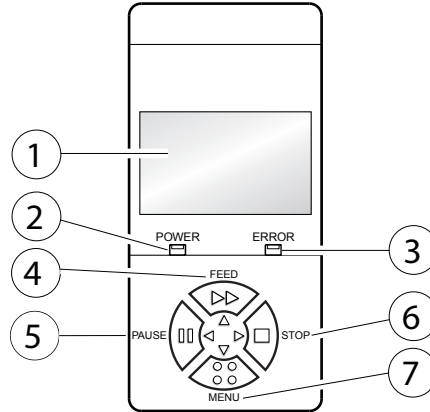

*LED Functions (p.22)*

*Normal Operating Mode (p.21)*

*Menu Setup Mode (p.37)*

- ① **LCD display**  
This displays the operational status of the printer.
- ② **POWER LED**  
This is lit when the printer power is on. (green)
- ③ **ERROR LED**  
This is lit or flashes when the printer is in an alarm or error status. (orange)
- ④ **FEED key**  
This key feeds the media to the top of the next label or form.
- ⑤ **PAUSE key**  
This temporarily stops printing.
- ⑥ **STOP key**  
This stops printing or cancels the alarm.
- ⑦ **MENU key**  
In normal operation, this key will enter the menu configuration mode. It can be configured to repeat the previous label, if preferred.

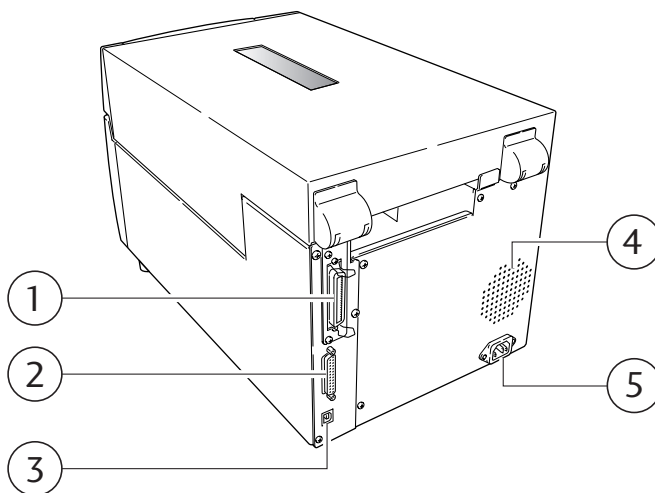

**Rear View**

*Parallel Interface (p.72)*

*Serial Interface (p.70)*

*USB Interface (p.75)*

*Connection to Power (p.18)*

- ① **Parallel interface (Centronics parallel or IEEE1284)**  
This receives parallel transmission of data from a host computer.
- ② **Serial interface (RS232C)**  
This receives serial transmission of data from a host computer.
- ③ **USB interface**  
This receives USB transmission of data from a host computer.
- ④ **Heat air opening**  
It allows warm air to vent from the printer.  
Be sure not to block it with media etc.
- ⑤ **Power cord inlet**  
The connector of the enclosed power cord is connected here.

## Connection to Power

1. The power switch is located on the front of the printer recessed below the control panel. Check that the power switch is turned OFF.
2. Insert the power cord in to the inlet on the printer.
3. Insert the plug of the power cord in the AC outlet.

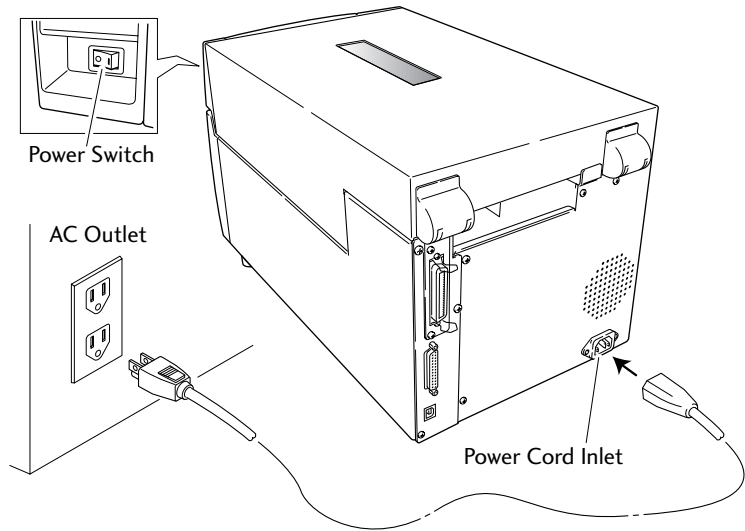

### Caution

Use an AC outlet that accepts a three-pronged plug. Otherwise, static electricity may be generated and there will be danger of electric shock.

## Driver Installation

The computer may automatically detect the presence of the new printer when it is first started, depending on the computer type, interface and operating system. Follow any on-screen instruction and also instructions supplied with your printer. Your supplier will assist you with the correct drivers and software which are compatible with your particular computer system.

## Connection to a Computer

This product has three interfaces that can be used to receive printing data: a serial port (RS232C), parallel port (IEEE1284, Non-L. P. S.), and a USB port (USB1.1). An optional internal network interface can be added by your dealer.

To connect the cable, proceed as follows:

1. Turn OFF both power switches of the printer and the computer.
2. Connect one end of the interface cable to the interface connector on the back of the printer and secure it with locks or locking screws, where available.
3. Connect the other end of the interface cable to the interface connector on the computer and secure it with locks or locking screws, where available.

*Serial Interface (p.70)*  
*Parallel Interface (p.72)*  
*USB Interface (p.75)*

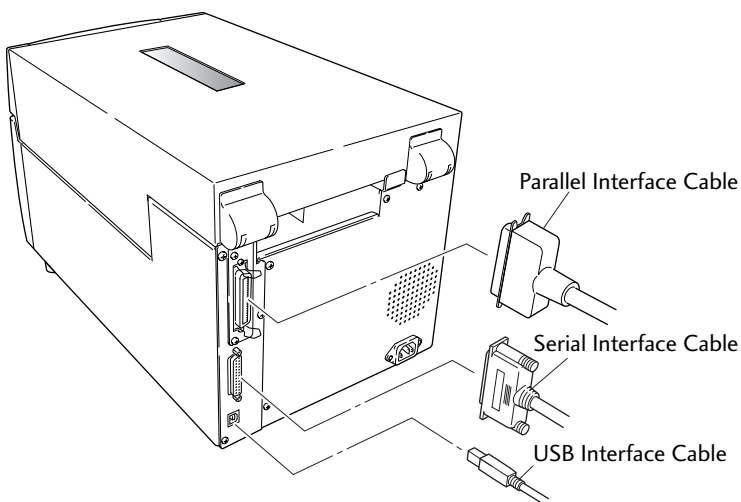

*Replacing the Interface Board (p.76)*

**Note:** If an optional network interface is used, the standard parallel port is removed from the printer, so the parallel interface cannot be used.

## Power ON/OFF

### Turning on the power

1. The power switch is conveniently located at the front of the printer for easy access during normal operation. It is in the recess underneath the control panel so it cannot be accidentally operated by mistake.
2. The POWER LED is lit.

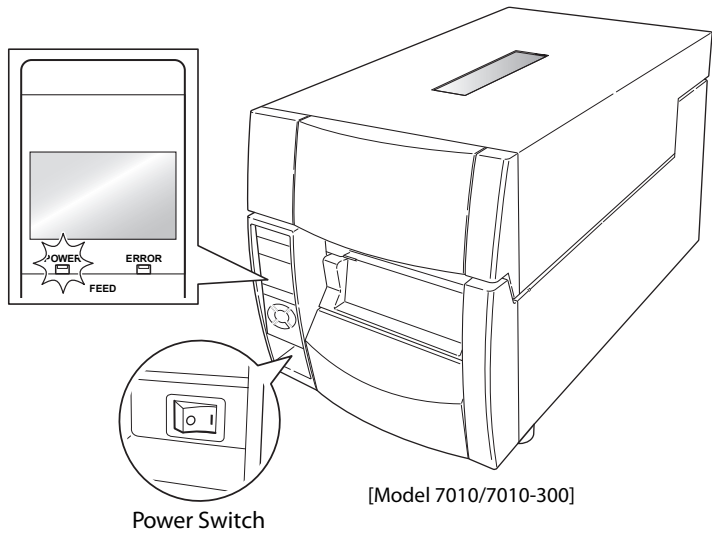

### Turning off the power

1. Turn off the power switch of the printer.
2. The POWER LED goes off.

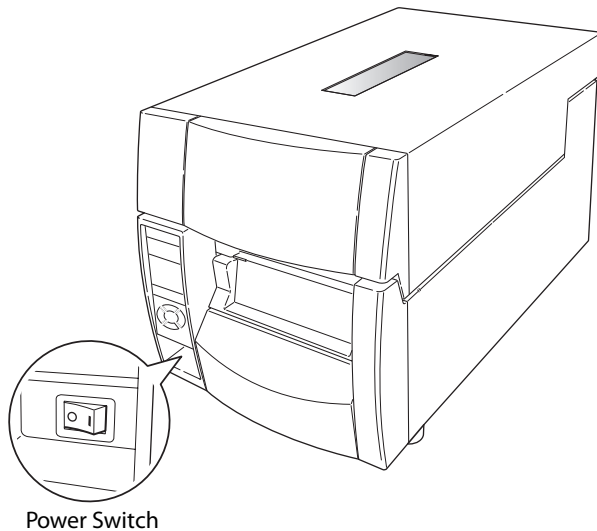

Menu Setup Mode (p.37)

## Normal Operating Mode

When the power is turned on, the printer enters normal operating mode. The control keys activate the following functions.

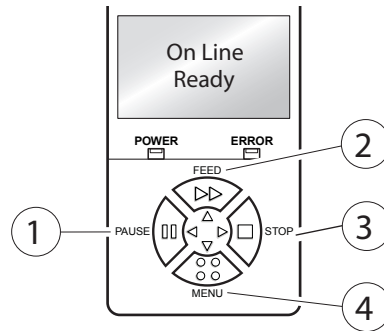

### ① PAUSE key: Temporarily pauses printing

- When this key is pushed once, the LCD indicates "Pause" and the printer temporarily pauses.
- When it is pushed during printing, the printer pauses after the label currently being printed is issued. Pressing the key a second time restarts printing and the remaining number of designated labels are printed.

### ② FEED key: Feeds media

- Pressing this key feeds media to the print start position. The distance it is fed is determined by automatically detecting the front end of the media when using label media, and when continuous media has been designated, a fixed quantity is fed, then feeding stops.
- When the TEAR OFF setting is effective, feeding stops when the media has been fed to the TEAR OFF location.
- When the optional cutter unit is installed, the media is fed to the cut position then it is cut.
- If the optional peeler unit is installed, the media is fed to the peeling location. When the media is pausing at the peeling position, feeding does not occur, even if the FEED key is pushed.

### ③ STOP key: It stops printing and cancels the alarm

Pushing this key once during printing puts the printer in pause mode after the label is issued. It is possible to cancel 1 batch of label issuing data by pressing the STOP key for 4 seconds or longer in pause status. (The LCD indicates "Job Clear" during cancel.)

### ④ MENU key:

In normal operation, this key will enter the menu configuration mode. It can be configured to repeat the previous label, if preferred.

Menu Setup Mode (p.37)

### LED Functions

#### ① POWER LED

It lights up when printer power is turned on. (green)

#### ② ERROR LED

This is lit or flashes when the printer is in error status. (orange)

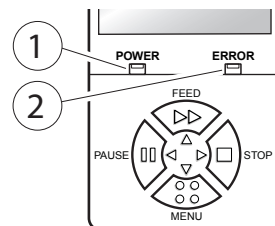

### Table of Alarm and Error Indications

In addition to normal operating mode, when an abnormal condition is detected in the printer, an alarm sounds and ERROR LED either lights up or flashes to indicate the type of error. The LCD indicates the error message.

Item	ERROR LED	LCD
Printing possible (no error)	OFF	On Line
Stop or Pause key on operation panel pressed	OFF	Pause
Head temperature - high temperature abnormality	Flashing	Alarm Head Hot
Head temperature - low temperature abnormality	Flashing	Error Head Cold
PF motor temperature abnormality	Flashing	Alarm PFMotor Hot
Fan motor malfunction	Flashing	Error Fan Lock
Cutter motor temperature abnormality	Flashing	Alarm Cutter Hot
Head open	Flashing	Error Head Open
Paper end	Flashing	Error Paper End
Paper out (paper position undetectable)	Flashing	Error Paper Load
Paper jam	Flashing	Error Paper Jam
Head low resistance value abnormality	Flashing	Alarm Head Check
Ribbon end	Flashing	Error Ribbon End
Communication error (receiving buffer overrun)	Flashing	Error Serial Over Run
Communication error (parity)	Flashing	Error Serial Parity
Communication error (framing)	Flashing	Error Serial Framing
Cover open	Flashing	Error Cover Open
*Auto-cutter abnormality (foreign object etc.)	Flashing	Error Cutter Fail
**Rewinder full (7010R only)	Flashing	Error Rewinder Full
**Rewinder cover open (7010R only)	Flashing	Error Rewinder Oper
**Rewind fail (7010R only)	Flashing	Error Rewind Fail
**Rewinder Hot (7010R only)	Flashing	Alarm Rewinder Hot

\* Applicable only when using the optional auto cutter

\*\* Applicable only with the rewinder version

# Setting the Media

## Media Sizes

The position of label and tag media is sensed by either a transparent sensor or a reflective sensor.

Transparent sensor: Detects the gaps between label media and notches of tag media

Reflective sensor: Detects the black mark

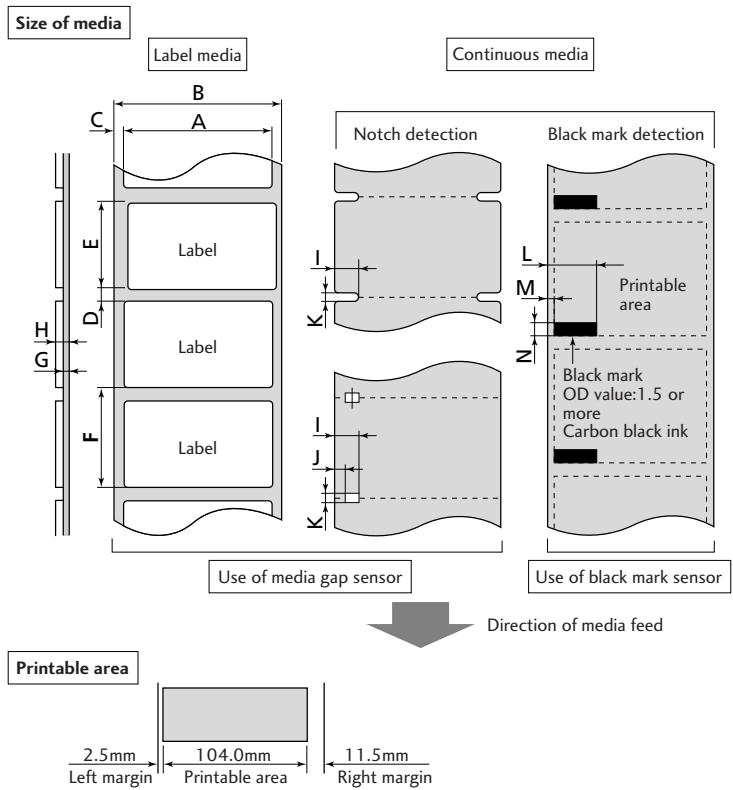

## Setting the Media

### When Using Front Sensors

		Minimum value mm (in)		Maximum value mm (in)	
A	Label width	7.62	(0.3)	118.00	(4.65)
B	Liner width	25.40	(1.0)	118.00	(4.65)
C	Left end of label	0	(0)	2.54	(0.10)
D	Gap between labels	2.54	(0.10)	812.80	(32.00)
E	Label length	6.35	(0.25)	812.80	(32.00)
F	Label pitch	6.35	(0.25)	812.80	(32.00)
G	Liner thickness	0.06	(0.0025)	0.125	(0.0049)
H	Media thickness	0.06	(0.0025)	0.25	(0.01)
I	Right end of notch	8.3	(0.32)	11	(0.43)
J	Left end of notch	0	(0)	4.7	(0.19)
K	Notch length	2.54	(0.10)	17.80	(0.70)
L	Right end of black mark	15.00	(0.59)	—	—
M	Left end of black mark	0	(0)	1.5	(0.06)
N	Black mark width	3.18	(0.125)	17.80	(0.70)

*Menu Setting Table (p.43)*

- \* Use a transparent sensor for label media gaps and media with black marks.
- \* Use a transparent sensor for fan fold media.
- \* If the label pitch is 1 inch or less, set the Small Media Adjustment menu to ON and match it to the label that uses the value of the Small Media Length menu.

### When Using Adjustable Sensor

		Minimum value mm (in)		Maximum value mm (in)	
A	Label width	25.24	(1.0)	118.00	(4.65)
B	Liner width	25.24	(1.0)	118.00	(4.65)
C	Left end of label	0	(0)	2.54	(0.10)
D	Gap between labels	2.54	(0.10)	812.80	(32.00)
E	Label length	12.70	(0.50)	812.80	(32.00)
F	Label pitch	12.70	(0.50)	812.80	(32.00)
G	Liner thickness	0.05	(0.0025)	0.125	(0.0049)
H	Media thickness	0.05	(0.0025)	0.25	(0.01)
I	Right end of notch	3.6	(0.14)	60.8	(2.39)
J	Left end of notch	0	(0)	57.2	(2.25)
K	Notch length	2.54	(0.10)	17.80	(0.70)
L	Right end of black mark	15.00	(0.59)	66.5	(2.62)
M	Left end of black mark	0	(0)	51.5	(2.02)
N	Black mark width	3.18	(0.125)	17.80	(0.70)

*Menu Setting Table (p.43)*

- \* Use a transparent sensor for label media gaps and media with black marks.
- \* Use a transparent sensor for fan fold media.
- \* If the label pitch is 1 inch or less, set the Small Media Adjustment menu to ON and match it to the label that uses the value of the Small Media Length menu.



### Installing the Media

1. Push the large blue head-open lever to release the head unit, and then lift the sensor arm by hand as shown below.

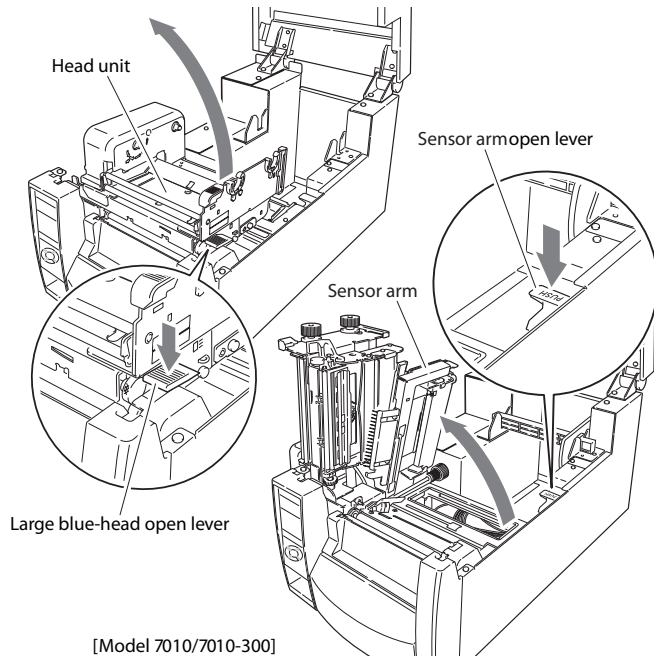

2. Firstly, slide the two black plastic parts of the media holder assembly together. Ensure correct alignment of the guide with the bar as it can only be installed in one direction.
3. Slide the roll of media over the media bar. The media guide must be on the right side of the roll of media (as viewed from the front of the printer) with the flat surface of the media guide touching the roll.

*Media Sizes (p.23)*

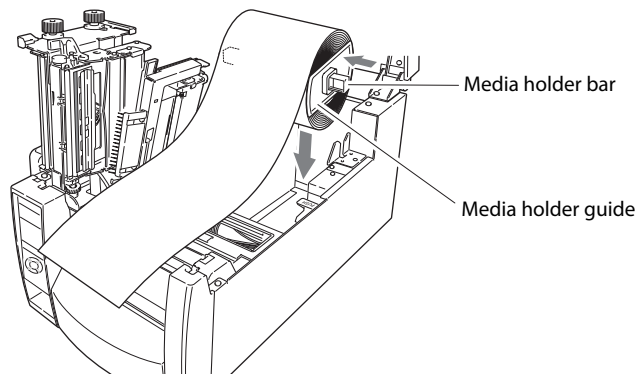

## Setting the Media

4. Set the media roll and media holder in to the printer as shown above. It is advisable to pull a length of media forwards and through the mechanism ready for later positioning.
5. Move the media roll so it is touching the left side of the housing. Then slide the black movable media guide so it is touching the media on the right side.

**Note:** Do not try to hold the media too tightly with these guides as it will cause the printer to jam during printing.

6. Align the media with the left fixed media guide (2 locations), align the right movable media guide with the media width, and lower the sensor arm which loosely holds the media in position.

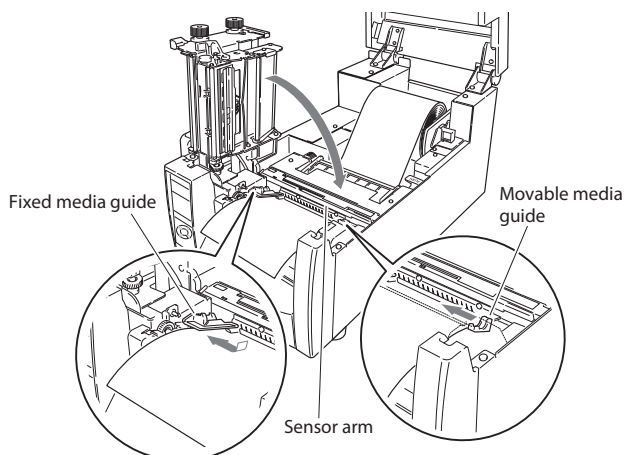

7. Lower the head unit back down to the closed position. Push the head close knob firmly to close and lock the mechanism. The mechanism is only locked correctly when you head a “click”. Align it with the width of the media that has been set, then set the media width adjustment screw and the media thickness adjustment knob. See “Chapter 3 Printer Adjustments”.

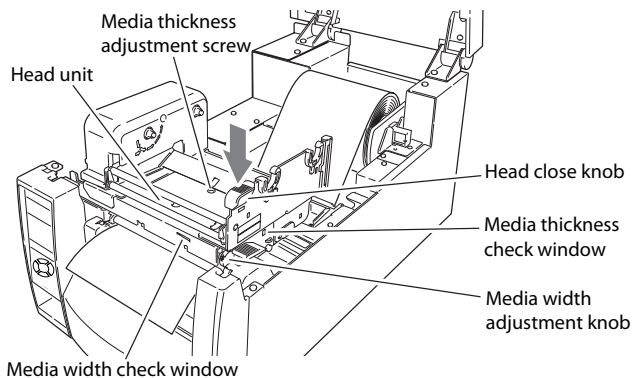

8. With the power switched on, push the FEED key to feed the media. It will halt at the next print start position.

*Media Thickness Adjustment*  
(p.57)

*Media Width Adjustment*  
(p.58)

**Using the Rewinder as a Peeler  
(7010R models/Peeling Mode)**

1. Ensure that the optional rewriter paper guide is not installed.

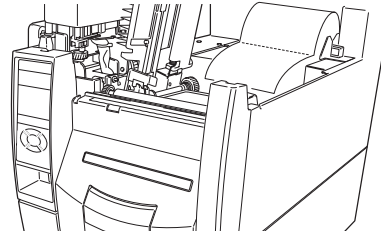

2. Open the rewriter cover and remove the rewriter flange.

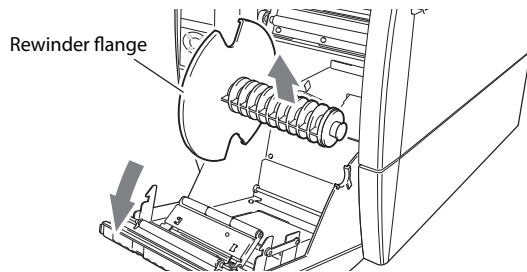

3. Pull out approximately 40cm length of the media from the head unit.

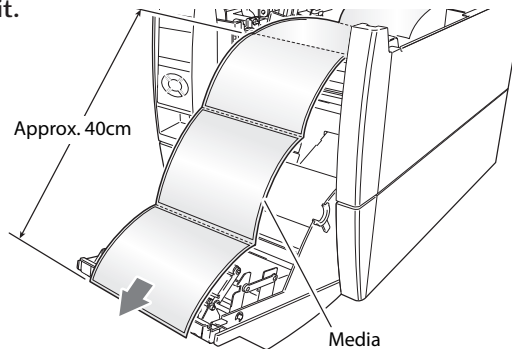

4. Peel off a number of labels at the tip part of the media from the liner so that the liner unit is in contact with the peeler roller when closing the rewriter cover.

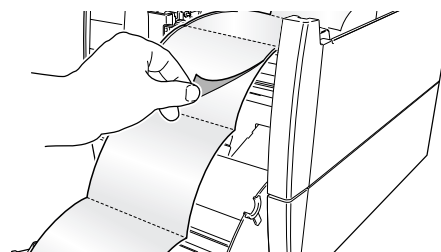

## Setting the Media

5. Insert the end of the liner in to the slot in the rewinder flange and wind the liner on to itself with two or three turns to ensure it is held properly. Set the rewinder flange back in to the printer.

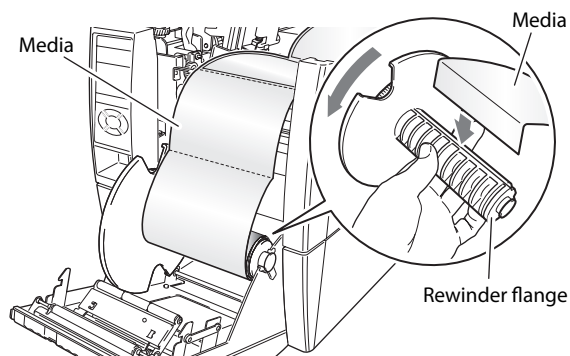

*Installing the Media (P.25)*

6. Confirm that the liner unit is in place in the peeler roller and close the rewinder cover.

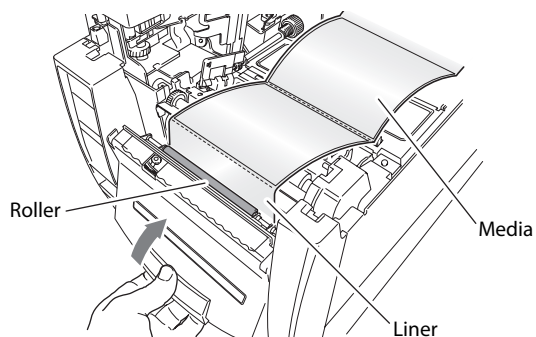

### **Caution**

When closing the rewinder cover, be careful not to catch any foreign objects or fingers in the mechanism.

### Using the Rewinder for Batches of Printed Media (7010R models/Rewind Mode)

The optional Rewinder Paper Guide is necessary for batch mode rewinding. The optional Adjustable Rewinder Flange is necessary if a paper core is to be installed to receive the media.

1. Hook the rewriter paper guide on the top of the rewriter cover.

Rewriter paper guide

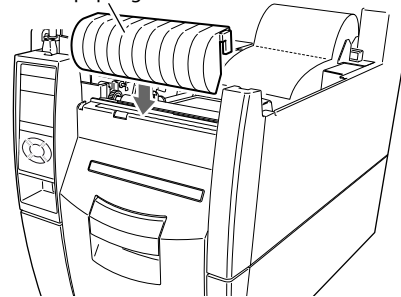

2. Slide the media enter slit cover above the rewriter cover to the left or right while pressing down on its center and remove.

Media enter slit cover

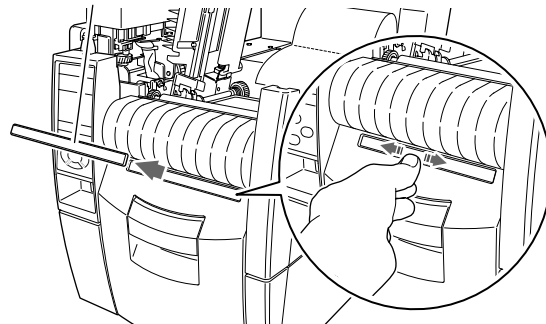

3. Open the rewriter cover and remove the rewriter flange.

Rewriter flange

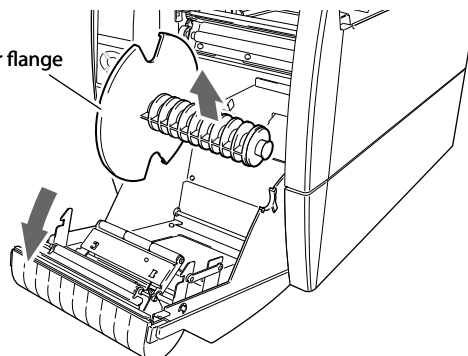

## Setting the Media

4. Pull out approximately 80cm length of media from the head unit.

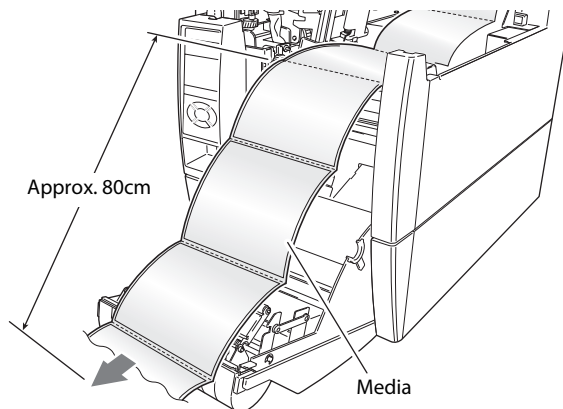

5. Insert the tip of the media through the media enter slit from the external side of the rewriter cover.

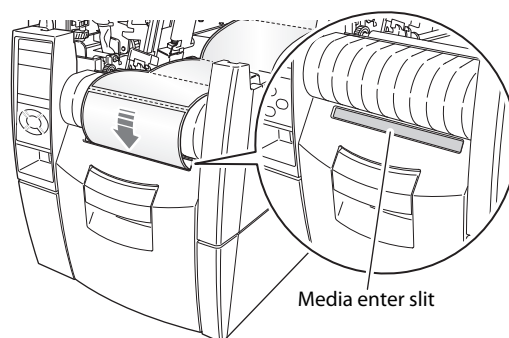

6. Insert the end of the media in to the slot in the rewriter flange and wind the media on to itself with two or three turns to ensure it is held properly. Set the rewriter flange back in to the printer.

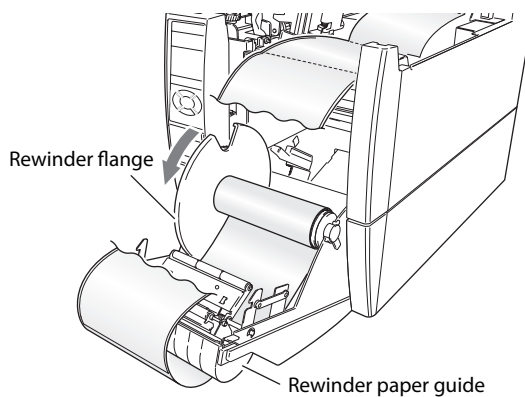

7. If the optional adjustable rewriter flange is being used with a paper core, the media can be attached to the paper core directly with tape or glue. Then the flange is set in the printer. For details on installing and removing the cardboard refer to the instructions contained with the adjustable flange.

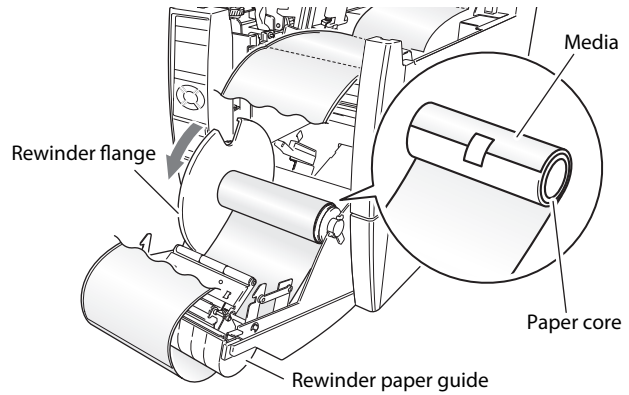

## Setting the Ribbon

The following kinds and sizes of ribbons can be used.

Types .....	Inside wound and outside wound ribbon
Max. ribbon width .....	114.0 mm (4.50 inch)
Min. ribbon width .....	25.4 mm (1.00 inch)
Max. ribbon length.....	450.0 m (1,476 ft)
Max. roll diameter .....	86.5 mm (3.40 inch)
Inner diameter of the paper core ....	$25.4 \pm 0.25$ mm ( $1.00 \pm 0.01$ inch)
Lead tape length .....	Less than 80.0 mm

### Setting method

1. Place the attached ribbon and paper core separately on one of the two attached ribbon holders. Insert the two ribbon holders into the ribbon and paper cores ensuring that they are pushed in all the way.

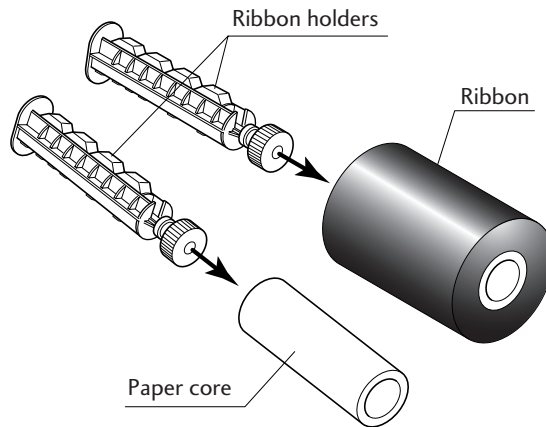

2. Install the unused ribbon and holder in to the rear ribbon drive unit. The splines on the ribbon drive gear mechanism engage with the end of the ribbon holder.

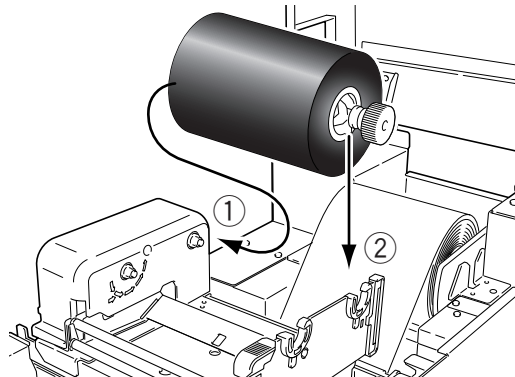



3. Push the large blue head-open lever to release the head unit. Pull out the ribbon from the bottom of the head unit to the ribbon winding side.

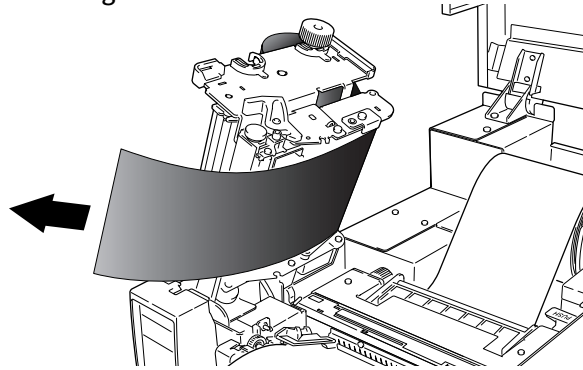

4. Using tape etc., fix the ribbon that you have pulled out on the ribbon holder on which the paper core has been set and wind it on the ribbon holder.

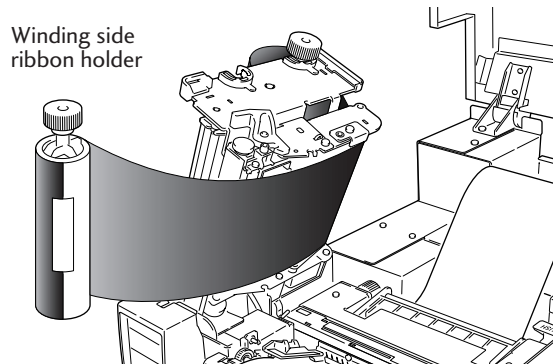

5. Set the ribbon holder on which the paper core has been set in the ribbon drive unit, then rotate it in the direction shown by the arrow to remove slack and wrinkles from the ribbon.

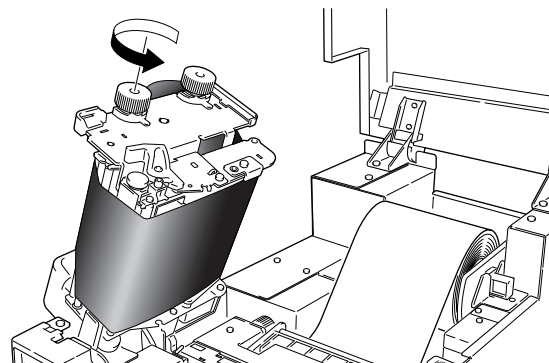

## Setting the Ribbon

*Adjusting the Ribbon (p.59)*

6. Lower the head unit back down to the closed position. Push the head close knob firmly to close and lock the mechanism. The mechanism is only locked correctly when you hear a “click”. If the ribbon is wrinkled, push the FEED key until the wrinkles disappear. If the wrinkles do not disappear or if it slips, perform ribbon tension adjustment and media width adjustment. See “Chapter 3 Printer Adjustments” for these adjustment methods.

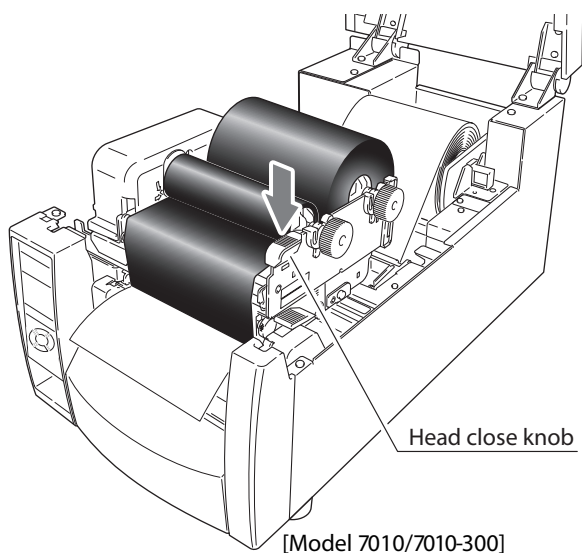

Operation Panel (P.16)

## Mode Settings

Turning on the power while pressing keys in the following combinations starts various functions.

Mode	Key operation
HEX dump mode	Turning power on while pushing the STOP key.
Self print mode	Turning power on while pushing the FEED key.
Menu list print mode and Menu setup mode	Turning power on while pushing the MENU key.

### HEX Dump Mode

- **When using label media**

Turn on printer power while pushing the STOP key. If the POWER LED is lit and the LCD indicates "Hex Dump Mode" and "Label Media", release the STOP key, and then the printer enters HEX DUMP mode.

- **When using continuous media**

Turn on printer power while pushing the STOP key. If the POWER LED is lit and the LCD indicates "Hex Dump Mode" and "Label Media", and then changed to "Hex Dump Mode" and "Cont. Media", release the STOP key, and then the printer enters HEX dump mode.

```

DUMP LIST
02 40 30 31 30 30 0D 02 60 30 30 32 30 0D 02 4C .M0100..c0020..L
44 31 31 0D 31 30 30 30 30 30 30 30 30 30 31 30 D11.10000000010
30 30 31 30 31 32 33 34 35 36 37 38 39 3A 3B 3C 0010123456789:<
    
```

DUMP LIST

\* To exit HEX Dump Mode, turn off the power to the printer then turn the power on again (restart).

*Setting the Media (P.23)*

### Self Print Mode

Performing a self test print is an easy way to check on the state of printer settings and printing quality. Install the media as explained in “Installing the Media” and then operate the printer as follows.

- **Case of label media**

Turn on printer power while pushing the FEED key. When the LCD indicates “Self Print Mode” and “Label Media”, release the FEED key. After it enters TEST MODE and media has fed, two labels print then printing stops. To repeat printing, press the FEED key once more.

- **Case of continuous media**

Turn on printer power while pushing the FEED key. When the LCD indicates “Self Print Mode” and “Label Media”, and then changed to “Self Print Mode” and “Cont. Media”, release the FEED key. After it enters TEST MODE and it prints then printing stops. To repeat printing, press the FEED key once more.

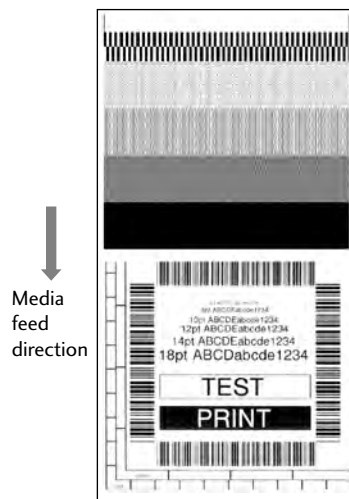

Self print pattern

### Media Adjustments

Using the Self Test Print shown above, you can make adjustments to the printer settings such as media width and media thickness (printhead pressure). For more details of the adjustment, refer to “Chapter 3 Printer Adjustments.”

*Media Thickness Adjustment (p.57)*

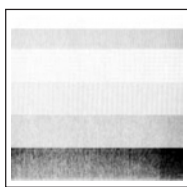

The first sample, left, shows an incorrectly set “media thickness adjustment”. For standard label media, the media thickness adjustment indicator should be set to the center scale in the window.

*Media Width Adjustment (p.58)*

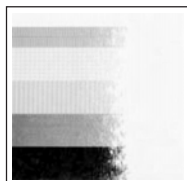

The second sample, left, shows an incorrectly set “media width adjustment”. For 4-inch or 100mm wide media, the adjuster should be set to the scale of 100 mm in the window.

The settings shown above are for general label media and may not apply to specialist media.

### Menu Setup Mode

If the MENU key is pressed while the printer is in the On Line Ready state, the printer enters menu setup mode. In this mode, the printer's configuration can be changed using the operation panel. During menu setting mode, the LCD indicates the current menu settings and the key function.

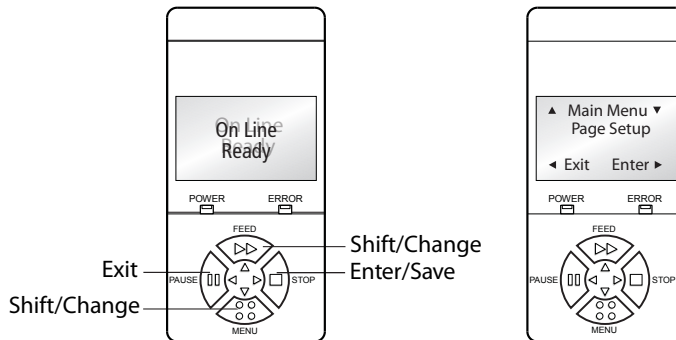

### Functions of the keys

When you enter Menu Setup Mode, the LCD displays "Main Menu" on the top line and Page Setup below.

In the menu setup mode, the four keys become "cursor keys" to navigate the menu. Refer to the four small arrows in the centre of the keypad rather than the names of the keys.

#### FEED key (Shift/Change)

The ▲ key (Feed key) goes up the menu system or selects a higher value

#### MENU key (Shift/Change)

The ▼ key (Menu key) goes down the menu system or selects a lower value

#### STOP key (Enter/Save)

The ► key (Stop key) selects or saves the item or enters a menu

#### PAUSE key (Exit)

The ◀ key (Pause key) exits the current item (goes back) and eventually exits the menu system

The menu settings are stored temporarily in the printer's memory. They are only permanently stored in the printer setup when you exit the menu system and say "Yes" to the "Save Settings" question.

### Caution

Turning the power off while the printer is performing the "Save Settings" function could cause a mis-save. Do not do this! If the power is accidentally turned off, first reset the printer to factory defaults.

### Example of changing a menu

This is an explanation of the method of changing the set value of print darkness from “12” to “14” in a case where the main menu is “Page Setup” and the sub menu is “Print Darkness”.

#### 1. Entering Menu Setup Mode.

Ensure LCD displays “On Line Ready”. Then press the MENU key to enter ‘menu setup mode’ where the printers settings can be changed or confirmed.

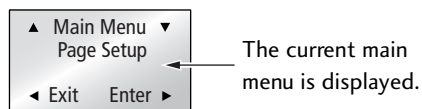
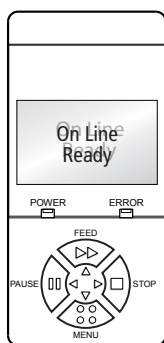

The following are the functions of each key.

- ▲ key: displays the previous menu item
- ▼ key: displays the next menu item
- ▶ key: enters the Page Setup menu
- ◀ key: enters the Save Settings section

#### <Main menu item flow>

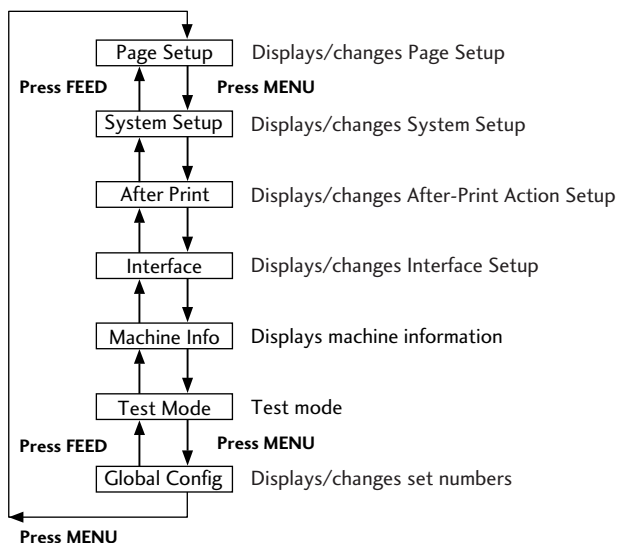

2. Entering Sub menu.

Press the ► key. The currently set item, “Print Speed”, is displayed.

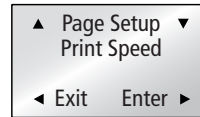

The following are the functions of each key.

- ▲ key: displays the previous sub menu
- ▼ key: displays the next sub menu
- key: displays the values set by the selected sub menu
- ◀ key: returns to the main menu

3. Selecting “Print Darkness” from the sub menu.

Press the ▼ key one time to display “Print Darkness”. It is the second item within “Page Setup”.

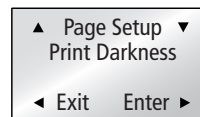

4. Displaying the set value of “Print Darkness”.

Press the ► key and the value “12” - the currently set value - is displayed.

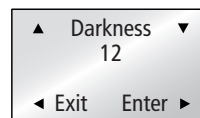

The following are the functions of each key.

- ▲ key: displays the higher value (13, in this case)
- ▼ key: displays the lower value (11, in this case)
- key: the current value is temporarily saved
- ◀ key: exits “Print Darkness” and ignores any value changes

5. To change the value of Print Darkness to 14.

Press the ▲ key two times to display “14” on the screen. Then press the ► key to temporarily save the value into the printer RAM.

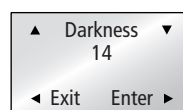

### 6. Save Changes to Settings.

Unless you save your settings, your changes will be lost when you turn off the printer.

#### To Save Changes

- 1 Press the ◀ key twice to display the message "Save Settings No-Discard".

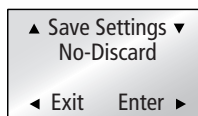

- 2 Press the ▲ key or the ▼ key to display the message "Save Settings Yes-Save".

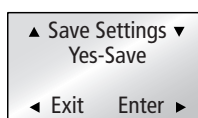

- 3 Press the ▶ key.  
The new settings will be saved and the printer will return to the "On Line Ready" screen.

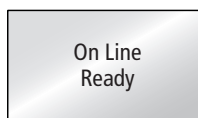

#### ■ Changing the Interface and Emulation Settings

Changes to interface or emulation settings require a printer restart (or reboot) to take effect. The printer will offer to do this when needed by displaying the following message after saving the settings:

- The screen shown on the right will be displayed when "Save Settings Yes-Save" is selected.

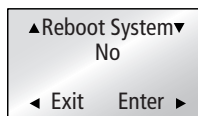

- Press the ▲ key or the ▼ key to display the message "Reboot System Yes".
- Press the ▶ key and reboot the printer.

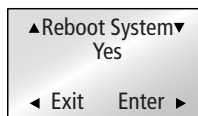

#### To Discard Changes

- 1 Press the ◀ key twice to display the message "Save Settings No-Discard".

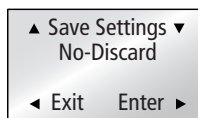

- 2 Press the ▶ key.  
The printer will return to the "On Line Ready" screen.  
The new settings will be lost when the printer is turned off.

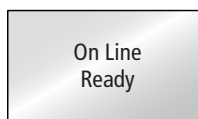



Example of changing a menu  
(p.38)

### Printing a List of Settings

You can get a list of the configuration settings in two ways:

- Press MENU key whilst turning the printer on. The Power LED flashes and “Print Settings” is displayed on the LCD. After printing, the printer will enter Menu Setup Mode.
- You can access the configuration print via the “Test Mode, Print Pattern, Current Config” from the setup menu.

Machine Information	
Model Number	: 7010
Boot Version	: ****
ROM Version	: *****
ROM Date(DD/MM/YY)	: XX/XX/XX
ROMCheck Sum	: ****
Head Check	: OK
Print Counter	: 0002.234km
Service Counter	: 0002.234km
Cut Counter	: 0
Sensor Monitor	: 1.50V
Option Interface	: None
Current Menu Setting	
[PageSetup Menu]	
Print Speed	: 7 IPS
Print Darkness	: 12
Darkness Adjust	: 00
Print Method	: Thermal Transfer
Continuous Media Length	: 4.00 inch
Vertical Position	: 0.00 inch
Horizontal Shift	: 0.00 inch
Vertical Image Shift	: 0.00 inch
Sensor Select	: Rear Adj Sensor
Media Sensor	: See Through
Small Media Adjustment	: Off
Small Media Length	: 1.00 inch
Symbol Set	: PM
[System Setup Menu]	
Sensor Level	: 1.7 V
Paper End Level	: 2.80 V
Error Reporting	: On Printing
Cover Open Sensor	: Off
Buzzer Select	: On
Metric/Inch	: Inch
Max Media Length	: 10.00 inch
Setting Lock	: Off
Keyboard Lock	: Off
Control Cod	: STD
Emulation Select	: DM4
Emulation Auto Detect	: On
[After Print Menu]	
AutoConfigure	: On
Function Select	: Tear
Cutter Action	: Backfeed
Paper Position	: 0.00 inch
Menu Key Action	: Enters Menu
[Interface Menu]	
RS-232C Baudrate	: 9600
RS-232C Parity	: None
RS-232C Length	: 8 bit
RS-232C Stop bit	: 1 bit
RS-232C X-ON	: Yes
IEEE1284	: On
Web Monitor	: Auto
Network Address	: 000.000.000.000
Subnet Mask	: 000.000.000.000
Gateway Address	: 000.000.000.000
BOOTP	: Off
DHCP	: Off
USB Device Class	: Printer
USB VCOM Protocol	: Auto

<Example of 7010 Datamax® emulation selected>

**Note:** We continually enhance our printers with new options and settings based on our customer's requests. Extra or changed menu items may appear on the above print out in some cases.

## Mode Settings

### Global Configuration Sets

The printer can store three sets of configuration settings that can be recalled quickly and easily.

Each “Config Set” (1, 2 or 3) can contain completely different configuration settings for all menu parameters. For example, “Config Set 1” could be configured for 5 ips print speed, thermal transfer labels, print darkness 18.

“Config Set 2” next could be 8 ips continuous card media with black mark, print darkness 12.

The ability of having three sets of settings is ideal for someone who prints on different media types regularly, for example in a label printing bureau.

Global config settings can be printed using the “Test Menu, Print Pattern, Global Config” menu option. It will also display the currently active “Config Set”:

	Active Configuration Setting		
	Config 1	Config 2	Config 3
[PageSetup Menu]			
Print Speed	5	8	7
Print Darkness	18	12	12
Darkness Adjust	+00	+00	+00
Print Method	TT	TT	TT
Continuous Media Length	04.00inch	04.00inch	04.00inch
Vertical Position	+0.00inch	+0.00inch	+0.00inch
Horizontal Shift	+0.00inch	+0.00inch	+0.00inch
Vertical Image Shift	+0.00inch	+0.00inch	+0.00inch
Sensor Select	Rear Adj Sen	Rear Adj Sen	Rear Adj Sen
Media Sensor	See Through	Reflect	See Through
Small Media Adjustment	Off	Off	Off
Small Media Length	1.00inch	1.00inch	1.00inch
Symbol Set	PM	PM	PM
[System Setup Menu]			
Sensor Level	1.4V	1.4V	1.4V
Paper End Level	2.80V	2.80V	2.80V
Error Reporting	On Printing	On Printing	On Printing
Cover Open Sensor	Off	Off	Off
Buzzer Select	On	On	On
Metric/Inch	Inch	Inch	Inch
Max Media Length	10.00inch	10.00inch	10.00inch
Settings Lock	Off	Off	Off
Keyboard Lock	Off	Off	Off
Control Code	STD	STD	STD
Emulation Select	DM4	DM4	DM4
[After Print Menu]			
AutoConfigure	On	On	On
Function Select	Tear	Tear	Tear
Paper Position	+0.00inch	+0.00inch	+0.00inch
Message Menu	Message Menu	Message Menu	Message Menu

<Example of 7010 Datamax® emulation selected>

## Menu Setting Table

**Page Setup Menu** - allows you to change settings related to the media or print quality.

**System Setup Menu** - allows you to change settings for the printer hardware and basic control systems.

**After Print Menu** - changes how the printer reacts after the label has been printed.

**Interfaces** - changes interface parameters such as baud rate.

**Machine Information, Test Mode** - allows you to check and/or print test pages and information about the printer.

**Global Config menu** - allows you to switch between 3 complete 'config sets' contained within the printer.

### Menu Setting

Press the MENU key in print possible status to enter MENU Setup Mode. Use the keys on the operation panel according to the LCD display to setup the printer. The contents that can be setup on the printer are shown below. And the items that are actually displayed on the LCD are shown in [ ].

#### ■ Datamax® Emulation

Top Menu	Sub Menu	Default	Menu	Remarks
<b>Page Setup</b>	Print Speed*	7 IPS	2 to 10 IPS	[For 7010 and 7010R] Printing speed setting.
		7 IPS	2 to 8 IPS	[For 7010-300] Printing speed setting.
	Print Darkness	12	00 to 30	Adjusting print darkness.
	Darkness Adjust [Darkness Adj]	00	-10 to 10	Fine adjustment of darkness commands.
	Print Method	TT	TT (Thermal Transfer) DT (Direct Thermal)	Selection of Thermal Transfer (ribbon) or Direct Thermal.
	Continuous Media Length [Cont Media Len]	4.00 inch 101.6 mm	0.25 to 32.00 inch 6.4 to 812.8 mm	Setting media length of continuous media. Lower level = during mm mode.
	Vertical Position [Vertical Pos]	0.00 inch 0.0 mm	-1.00 to 1.00 inch -25.4 to 25.4mm	Adjusting printing start position.
	Horizontal Shift [Horizontal Shif]	0.00 inch 0.0 mm	-1.00 to 1.00 inch -25.4 to 25.4mm	Adjusting horizontal image position.
	Vertical Image Shift [Vertical Image]	0.00 inch 0.0 mm	0.00 to 32.00 inch 0.0 to 812.8mm	Adjust the off set value in vertical when mapping data on a RAM.
	Sensor Select	Rear Adj Sensor	Rear Adj Sensor Front Fixed Sen	Selecting front fixed/rear adj. sensor.
	Media Sensor	See Through	See Through Reflect None	Selecting media sensor.
	Small Media Adjustment [Small Media Adj]	Off	On Off	Setting for small media.
	Small Media Length [Small Media Len]	1.00 inch 25.4 mm	0.25 to 1.00 inch 6.4 to 25.4mm	Setting media length for small media.
	Symbol Set	PM	50 symbols	Setting symbol set.
	<b>System Setup</b>	Sensor Monitor	-	-
Sensor Level		1.4 V	0.0 V to 3.0 V	Selects threshold of the sensor.
Paper End Level		2.80 V	0.01 V to 3.00 V	Sets the paper end level.
Error Reporting [Error Report]		On Printing	On Printing Immediate	Setting for error report.

\* 2 to 7 IPS for 7010/7010-300 with optional peeler.

## Mode Settings [Datamax® Emulation]

Top Menu	Sub Menu	Default	Menu	Remarks
	Cover Open Sensor [Cover Sensor]	Off	On Off	Sets the cover open sensor.
	Buzzer Select	Exec/Err	Exec/Err All Error Key None	Setting buzzer sounding conditions.
	Metric/Inch [Metric/Inch Sel]	Inch	Inch mm	Sets the units.
	Max Media Length [Max Media Len]	10.00 inch 254.0 mm	1.00 to 50.00 inch 25.4 to 1270.0 mm	Sets the maximum media length.
	Settings Lock	Off	On Off	Prevents a command changing the set value.
	Keyboard Lock	Off	On Off	Prevents a change by a key operation. Note: Hold down the Menu Key for at least 4 seconds to enter the Menu Setup Mode when setting the "On" menu.
	Control Code	STD	STD ALT ALT-2	Switches command mode of DMX mode.
	Emulation Select [Emulation Sel]	DM4	DM4 DMI DPP ZPI2	Selects DataMax®/Zebra® compatibility DM4: DataMax® 400 DMI: DataMax® IClass DPP: DataMax® Prodigy Plus® ZPI2: Zebra® 2844Z
	Emulation Auto Detect [Emulation Auto]	On	On Off Full Auto	Setting emulation (as above) auto detection.
<b>After Print</b>	AutoConfigure [Auto Config]	On	On Off	Automatically configures optional devices. On ... AutoConfigure enabled (Regardless of whether Function Select is set, if a peeler or cutter is installed, each mode is set automatically.) Off ... AutoConfigure disabled (A peeler or cutter is installed, but to not operate the peeler or cutter, turn it Off and the operation is selected by Function Select.)
	Function Select [Function Sel]	Tear	Off Tear Peel On* Cut On** Rewind***	Selects the operation when the AutoConfigure is set to Off. Designates the paper position based on each option. The operation of this device is enabled during selection. At the same time, the parameters of the f command of Prodigy Plus are emulated for each optional device.
	Cutter Type	Standard	Standard Heavy Duty	Selects the cutter type. Standard: Model JN98901 Heavy Duty: Model JN98911
	Cutter Action	Backfeed	Backfeed Through	Sets the cutter action. With the optional AutoConfigure On, printing is executed only when the cutter is installed or only when Cut is selected by Function Select. Backfeed is always set after cutting. Through is set at the rear end of sheets 1 to n-1 when the number of copies = n, and the rear end of the final page of single sheet and the copy is backfeed.

\* Only when peeling option is mounted.

\*\* Only when cutter is mounted.

\*\*\* Only the Rewinder.

Top Menu	Sub Menu	Default	Menu	Remarks
	Rewinder Auto Online*** [Rew Auto Online]	Off	On Off	[7010R only] Sets the Rewinder Auto Online. In the case in which the setting is On, when the Rewinder Open Error occurs, if the Rewinder Cover is closed, it will automatically return to Online and printing will restart.
	Rewinder Online Delay*** [Rew OnlineDelay]	2 sec	1 to 10 sec	[7010R only] Sets the Rewinder Online Delay. Sets the time until the Rewinder restarts after the Rewinder Cover is closed when the above Rewinder Auto Online is On.
	Rewinder Torque***	4	1 to 7	[7010R only] Sets the Rewinder Torque.
	Peel Wait Delay**	0.1 sec	0.1 to 2.0 sec	Sets the Peel Wait Delay. Displays only machines with a peeler installed.
	Paper Position	0.00 inch 0.00 mm	Peel/Cut/Tear Off 0.00 to 2.00 inch 0.0 to 50.8 mm Peel/Cut/Tear On -1.00 to 1.00 inch -25.4 to 25.4 mm	Adjusts the stop position. It is based on the inch/millimeter setting. There are initial values of the stop position for each device set above, and later, relative values are set.
	Menu Key Action	Enters Menu	Enters Menu Repeat Last Set Repeat Last One	Sets the menu key action. Enters Menu: Enters the menu setup mode. Repeat Last Set: Repeats the number of copies. Repeat Last One: Last one is issued only for the final page. In the case of a count, afterwards, only last one is issued. Note: Hold down the MENU key for at least 4 seconds in order to enter the Menu Setup Mode when setting the "Repeat Last Set" or "Repeat Last One" menus.
<b>Interfaces</b>	RS-232C Baud	9600	115200 57600 38400 19200 9600 4800 2400	Setting the baud rate of the serial interface. • All settings related to the interface are enabled after the power is reconnected.
	RS-232C Parity	None	None Odd Even	Setting the communication parity for the serial interface.
	RS-232C Length	8 bits	8 bits 7 bits	Setting the character length for the serial interface.
	RS-232C Stop bit [RS-232C Stopbit]	1 bit	1 bit 2 bits	Setting the stop bit for the serial interface.
	RS-232C X-ON	On Yes	On Yes Off No	Selectively setting the X-ON flow control of the serial interface.
	IEEE1284	On	On Off	Setting both direction of the Centro Interface.
	Web Monitor	Auto	Auto On Off	Selecting the web monitor function.

\*\* Only when cutter is mounted.

\*\*\* Only the Rewinder.

# Printer Operation

## Mode Settings [Datamax® Emulation]

Top Menu	Sub Menu	Default	Menu	Remarks
	Network Address	0.0.0.0	0.0.0.0 to 255.255.255.255	Setting fixed IP address of the LAN board.
	Subnet Mask	0.0.0.0	0.0.0.0 to 255.255.255.255	Setting fixed subnet mask value of the LAN board.
	Gateway address	0.0.0.0	0.0.0.0 to 255.255.255.255	Setting fixed default gateway address of the LAN board.
	BOOTP	Off	On Off	Setting the BOOTP of the LAN board.
	DHCP	Off	On Off	Setting the DHCP of the LAN board.
	USB Device Class [USB Device Clas]	Printer	Printer VCOM	Selects the USB device class.
	USB VCOM Protocol [VCOM Protocol]	Auto	Auto DTR X-ON	Selects the protocol (flow control) when operating USB VCOM.
<b>Machine Information</b> [Machine Info]	Model Number	–	7010***	Displays the model name.
	Boot Version	–	*.*	Displays the boot version.
	ROM Version	–	*****	Displays the ROM version.
	ROM Date	–	**/**/**	Displays the date the ROM was prepared.
	ROM CheckSum	–	****	Displays the check sum of the ROM.
	Head Check	–	OK NG	Displays the results of the head check.
	Print Counter	–	****.*** km	Displays the print counter.
	Service Counter	–	****.*** km	Displays the service counter.
	Cut Counter	–	–	Displays the cut count.
	Sensor Monitor	–	*.* V	Displays the sensor level.
	Option Interface [Option I/F]	–	None LAN	Displays the presence/absence of the optional interface.
<b>Test Mode</b>	Print Pattern	Current Config	Current Config Global Config Sample	Executes the test pattern.
	Head Check	No	Yes No	Executes head check.
	Factory Default	No	Yes No	Initializes the set values of the configuration set to the state when the unit was shipped from the factory.
	Hex Dump	No	Yes No	Sets the hex dump mode.
	Serial Monitor	–	–	Displays the state of the serial interface.
	Auto Calibration [Auto Cal]	See Through	See Through Reflect	Executes the calibration of the sensor.
	Sensor Monitor	See Through	See Through Reflect	Displays the level of the sensor.
<b>Global configuration</b> [Global Config]	–	Config Set 1	Config Set 1 Config Set 2 Config Set 3	Sets the Config Set.

**Note:** To restore factory default settings, turn on printer power while pushing the MENU and PAUSE keys simultaneously, then press the FEED key and the STOP key sequentially.

### ■ Zebra® Emulation

Top Menu	Sub Menu	Default	Menu	Remarks	
Page Setup	Print Speed*	7 IPS	2 to 10 IPS	[For 7010/7010R] Printing speed setting.	
		7 IPS	2 to 8 IPS	[For 7010-300] Printing speed setting.	
	Print Darkness	12	00 to 30	Adjusting print darkness.	
	Darkness Adjust [Darkness Adj]	00	-10 to 10	Fine adjustment of darkness commands.	
	Print Method	TT	TT (Thermal Transfer) DT (Direct Thermal)	Selection of Thermal Transfer (ribbon) or Direct Thermal.	
	Continuous Media Length [Cont Media Len]	4.00 inch 101.6 mm	0.25 to 32.00 inch 6.4 to 812.8 mm	Setting media length of continuous media. Lower level = during mm mode.	
	Vertical Position [Vertical Pos]	0.00 inch 0.0 mm	-1.00 to 1.00 inch -25.4 to 25.4mm	Adjusting printing start position.	
	Horizontal Shift [Horizontal Shif]	0.00 inch 0.0 mm	-1.00 to 1.00 inch -25.4 to 25.4mm	Adjusting horizontal image position.	
	Sensor Select	Rear Adj Sensor	Rear Adj Sensor Front Fixed Sen	Selecting front fixed/rear adj. sensor.	
	Media Sensor	See Through	See Through Reflect None	Selecting media sensor.	
	Small Media Adjustment [Small Media Adj]	Off	On Off	Setting for small media.	
	Small Media Length [Small Media Len]	1.00 inch 25.4 mm	0.25 to 1.00 inch 6.4 to 25.4mm	Setting media length for small media.	
	Symbol Set	PM	50 symbols	Setting symbol set.	
	System Setup	Sensor Monitor	-	-	Displays level of sensor that is currently selected.
		Sensor Level	1.4 V	0.0 V to 3.0 V	Selects threshold of the sensor.
Paper End Level		2.80 V	0.01 V to 3.00 V	Sets the paper end level.	
Error Reporting [Error Report]		On Printing	On Printing Immediate	Setting for error report.	
Cover Open Sensor [Cover Sensor]		Off	On Off	Sets the cover open sensor.	
Buzzer Select		Exec/Err	Exec/Err All Error Key None	Setting buzzer sounding conditions.	
Metric/Inch [Metric/Inch Sel]		Inch	Inch mm	Sets the units.	
Max Media Length [Max Media Len]		10.00 inch 254.0 mm	1.00 to 50.00 inch 25.4 to 1270.0 mm	Sets the maximum media length.	
Settings Lock		OffOn	Off	Prevents a command changing the set value.	
Keyboard Lock		Off	On Off	Prevents a change by a key operation. Note: Hold down the Menu Key for at least 4 seconds to enter the Menu Setup Mode when setting the "On" menu.	

\* 2 to 7 IPS for 7010/7010-300 with optional peeler.

## Mode Settings [Zebra® Emulation]

Top Menu	Sub Menu	Default	Menu	Remarks
	Media Power Up	Off	On Off	Selects whether or not to initiate media measurement when the power is ON.
	CI Lock	Off	On Off	Activates/deactivates the CI command.
	Emulation Select [Emulation Sel]	ZPI2	DM4 DMI DPP ZPI2	Selects DataMax®/Zebra® compatibility DM4: DataMax® 400 DMI: DataMax® IClass DPP: DataMax® Prodigy Plus® ZPI2: Zebra® 2844Z
	Emulation Auto Detect [Emulation Auto]	On	On Off Full Auto	Setting emulation (as above) auto detection.
<b>After Print</b>	AutoConfigure [Auto Config]	On	On Off	Automatically configures optional devices. On ... AutoConfigure enabled (Regardless of whether Function Select is set, if a peeler or cutter is installed, each mode is set automatically.) Off ... AutoConfigure disabled (A peeler or cutter is installed, but to not operate the peeler or cutter, turn it Off and the operation is selected by Function Select.)
	Function Select [Function Sel]	Tear	Off Tear Peel On* Cut On** Rewind***	Selects the operation when the AutoConfigure is set to Off. Designates the paper position based on each option. The operation of this device is enabled during selection. At the same time, the parameters of the f command of Prodigy Plus are emulated for each optional device.
	Cutter Type	Standard	Standard Heavy Duty	Selects the cutter type. Standard: Model JN98901 Heavy Duty: Model JN98911
	Cutter Action	Backfeed	Backfeed Through	Sets the cutter action. With the optional AutoConfigure On, printing is executed only when the cutter is installed or only when Cut is selected by Function Select. Backfeed is always set after cutting. Through is set at the rear end of sheets 1 to n-1 when the number of copies = n, and the rear end of the final page of single sheet and the copy is backfeed.
	Rewinder Auto Online*** [Rew Auto Online]	Off	On Off	[7010R only] Sets the Rewinder Auto Online. In the case in which the setting is On, when the Rewinder Open Error occurs, if the Rewinder Cover is closed, it will automatically return to Online and printing will restart.
	Rewinder Online Delay*** [Rew OnlineDelay]	2 sec	1 to 10 sec	[7010R only] Sets the Rewinder Online Delay. Sets the time until the Rewinder restarts after the Rewinder Cover is closed when the above Rewinder Auto Online is On.
	Rewinder Torque***	4	1 to 7	[7010R only] Sets the Rewinder Torque.
	Peel Wait Delay**	0.1 sec	0.1 to 2.0 sec	Sets the Peel Wait Delay. Displays only machines with a peeler installed.

\* Only when peeling option is mounted.

\*\* Only when cutter is mounted.

\*\*\* Only the Rewinder.



Top Menu	Sub Menu	Default	Menu	Remarks
	Paper Position	0.00 inch 0.00 mm	Peel/Cut/Tear Off 0.00 to 2.00 inch 0.0 to 50.8 mm Peel/Cut/Tear On -1.00 to 1.00 inch -25.4 to 25.4 mm	Adjusts the stop position. It is based on the inch/millimeter setting. There are initial values of the stop position for each device set above, and later, relative values are set.
	Menu Key Action	Enters Menu	Enters Menu Repeat Last One	<p>Sets the menu key action.</p> <p>Enters Menu: Enters the menu setup mode.</p> <p>Repeat Last One: Last one is issued only for the final page. In the case of a count, afterwards, only last one is issued.</p> <p>Note: Hold down the MENU key for at least 4 seconds in order to enter the Menu Setup Mode when setting the "Repeat Last One" menu.</p>
<b>Interfaces</b>	RS-232C Baud	9600	115200 57600 38400 19200 9600 4800 2400	<p>Setting the baud rate of the serial interface.</p> <ul style="list-style-type: none"> <li>All settings related to the interface are enabled after the power is reconnected.</li> </ul>
	RS-232C Parity	None	None Odd Even	Setting the communication parity for the serial interface.
	RS-232C Length	8 bits	8 bits 7 bits	Setting the character length for the serial interface.
	RS-232C Stop bit [RS-232C Stopbit]	1 bit	1 bit 2 bits	Setting the stop bit for the serial interface.
	RS-232C X-ON	On Yes	On Yes Off No	Selectively setting the X-ON flow control of the serial interface.
	IEEE1284	On	On Off	Setting both direction of the Centro Interface.
	Web Monitor	Auto	Auto On Off	Selecting the web monitor function.
	Network Address	0.0.0.0	0.0.0.0 to 255.255.255.255	Setting fixed IP address of the LAN board.
	Subnet Mask	0.0.0.0	0.0.0.0 to 255.255.255.255	Setting fixed subnet mask value of the LAN board.
	Gateway address	0.0.0.0	0.0.0.0 to 255.255.255.255	Setting fixed default gateway address of the LAN board.
	BOOTP	Off	On Off	Setting the BOOTP of the LAN board.
	DHCP	Off	On Off	Setting the DHCP of the LAN board.
	USB Device Class [USB Device Clas]	Printer	Printer VCOM	Selects the USB device class.
	USB VCOM Protocol [VCOM Protocol]	Auto	Auto DTR X-ON	Selects the protocol (flow control) when operating USB VCOM.

## Mode Settings

### [Zebra® Emulation]

Top Menu	Sub Menu	Default	Menu	Remarks
<b>Machine Information</b> [Machine Info]	Model Number	–	7010*	Displays the model name.
	Boot Version	–	*.*	Displays the boot version.
	ROM Version	–	*****	Displays the ROM version.
	ROM Date	–	**/**/**	Displays the date the ROM was prepared.
	ROM CheckSum	–	****	Displays the check sum of the ROM.
	Head Check	–	OK NG	Displays the results of the head check.
	Print Counter	–	****.*** km	Displays the print counter.
	Service Counter	–	****.*** km	Displays the service counter.
	Cut Counter	–	–	Displays the cut count.
	Sensor Monitor	–	*.* V	Displays the sensor level.
	Option Interface [Option I/F]	–	None LAN	Displays the presence/absence of the optional interface.
<b>Test Mode</b>	Print Pattern	Current Config	Current Config Global Config Sample	Executes the test pattern.
	Head Check	No	Yes No	Executes head check.
	Factory Default	No	Yes No	Initializes the set values of the configuration set to the state when the unit was shipped from the factory.
	Hex Dump	No	Yes No	Sets the hex dump mode.
	Serial Monitor	–	–	Displays the state of the serial interface.
	Auto Calibration [Auto Cal]	See Through	See Through Reflect	Executes the calibration of the sensor.
	Sensor Monitor	See Through	See Through Reflect	Displays the level of the sensor.
<b>Global configuration</b> [Global Config]	–	Config Set 1	Config Set 1 Config Set 2 Config Set 3	Sets the Config Set.

**Note:** To restore factory default settings, turn on printer power while pushing the MENU and PAUSE keys simultaneously, then press the FEED key and the STOP key sequentially.

*Menu Setup Mode (p.37)*

## Quick Setup of the Print Method

The print method (thermal transfer method/direct thermal method) can be set using operation panel in addition to menu setting mode.

### Caution

Be sure to always shut off the operation of print before changing a setting. You cannot change a setting during printing (including pause).

### Setting method

Keep the MENU key held down. Each time the PAUSE key is pushed, the printer switches between thermal transfer mode and direct thermal mode.

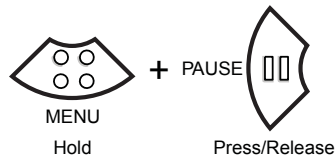

- If thermal transfer is selected, the buzzer sounds once and the LCD briefly displays "Print Method, TT" before returning on-line.
- If direct thermal is selected, the buzzer sounds twice and the LCD briefly displays "Print Method, DT" before returning on-line.

**Note:** If you just press the MENU button on its own and do not press PAUSE, you will enter the full Menu Setup Mode.

*Menu Setup Mode  
(p.27, p43, p47)*

## Emulation Auto-Detection

Ordinarily emulation switching is conducted in the Menu Setup mode. However, switching can also be conducted using the Emulation Auto-Detection function outlined below.

The following message is displayed on the LCD when the Zebra® emulation (ZPI2) command is detected during Datamax® emulation.

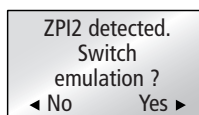

ZPI2 detected.  
Switch  
emulation ?  
◀ No Yes ▶

By selecting “Yes” the printer will reboot and automatically switch to ZPI2 emulation. The printer will return to the On Line Ready status if “No” is selected.

The following message is displayed in the LCD when the Datamax® command is detected during Zebra® emulation.

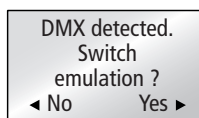

DMX detected.  
Switch  
emulation ?  
◀ No Yes ▶

By selecting “Yes” the printer will reboot and automatically switch to Datamax® emulation (DM4/DMI/DPP). The printer will return to the On Line Ready status if “No” is selected.

- Note:**
- The Emulation Auto-Detection function will not work if the “Emulation Auto Detect” command in the Sub Menu in the “System Setup” in the Top Menu is set to “Off”. (The command is set to “On” when shipped from the factory)
  - After the Emulation Auto-Detection function is activated, this function will not work unless the printer is turned Off and then turned On again.
  - If the “Emulation Auto Detect” function is set to “Full Auto”, this will cause the printer to automatically restart when it detects an alternative emulation. This is useful for remotely located machines where the control panel cannot be accessed.

## Setting the menu for the Rewinder (7010R only)

*Menu Setup Mode (p.37)*

*Menu Setting Table (p.43)*

Set the Menu Setup Mode as follows to use the rewinder function.

### When rewinding the liner using the peeler

Ensure that the "Function Sel (sub menu)" is set to "Peel On".  
When the "Auto Config (sub menu)" is set to "On", "Peel On" mode is automatically selected.

### When rewinding printed media without using the peeler

Set the "Function Sel (sub menu)" to "Rewind".

### IMPORTANT!

If the "Rewind" operation is to be used permanently, you must switch the "Auto Config" menu option to "Off". Otherwise, when the printer is switched on again, the Auto Configuration selects Peel mode by default.

### Rewinder Capacity Display

The LCD shows how much liner or media is on the rewinder flange at any given time. If the rewinder is full, an error will be displayed on the LCD.

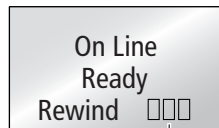

- ..... 0 to 33%
- ..... 33 to 66%
- ..... 66 to 99%
- ..... 100% (The LCD will indicate an error if you attempt to print in this state)
- ..... When the door is released
- Off ..... Rewinder function off

## Sensor Adjustments and Calibration

The sensing level of both the transparent (see thru) and reflective sensors is adjusted separately and independently. Firstly, the sensor type must be selected using the Sensor Method Selection shown below. Then the adjustment and calibration of the sensor can be made.

The front sensor or adjustable sensor is selected using the Adjustable sensor on the sub menu that is in Page Setup on the main menu. (See “Chapter 2. Printer Operation”). The adjustable rear sensor is set by Factory Default.

### Entering Sensor Adjustment Mode

1. Turn on the power while pushing the PAUSE key, FEED key, and STOP key simultaneously.

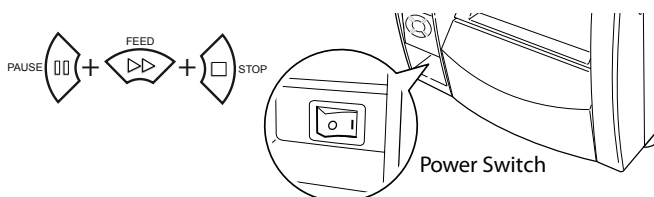

2. After “Sensor Cal Mode” lights up, release the keys to change the printer to sensor adjustment setting mode.

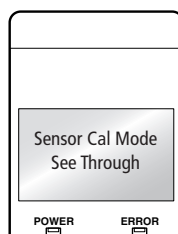

*Installing the Media  
(p.25, p27)*

### Quick Sensor Selection Method (Transparent ↔ Reflective)

To switch from transparent to reflective sensor, hold down the MENU key and then press the STOP key. Each time you press the STOP key, you switch to back and forth between the two sensor types.

If the transparent sensor is selected, “See Through” is displayed and the buzzer sounds once. If the reflective sensor is selected, “Reflect” is displayed and the buzzer sounds twice.

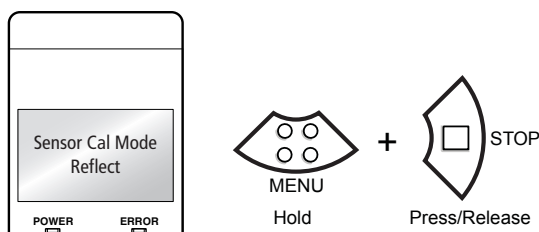

*Installing the Media*  
(p.25, p27)

*Quick Sensor Selection*  
*Method*  
(Transparent ↔ Reflective)  
(p.54)

### Adjusting the Transparent sensor

1. The transparent sensor is selected.
2. Install only the liner media (label backing paper) with the label media removed so that it will pass between the platen roller and the media sensor. (Be careful that media with black marks does not pass the media sensor.) Then close the sensor arm and the printhead.

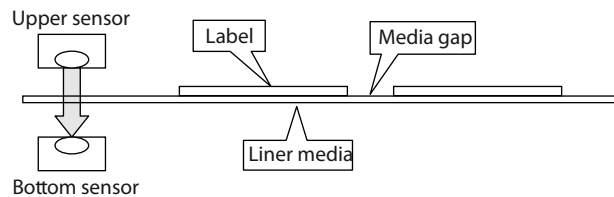
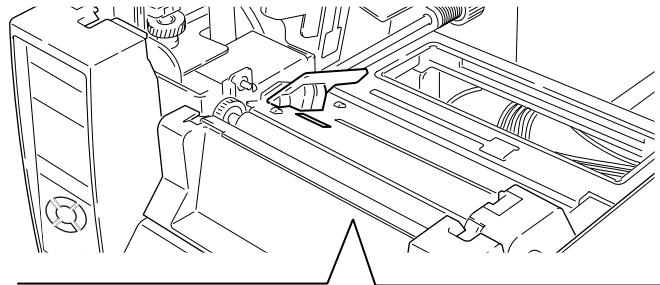

3. If the Pause Key is pressed then released while the MENU key is continually pressed, the sensor is automatically adjusted.

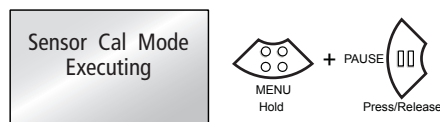

4. When automatic adjustment stops normally, "Succeeded" is displayed by the LCD. If it stops abnormally (adjustment is impossible), ERROR LED flashes and "Failed" is displayed on the LCD.



5. If the STOP key is pressed, the Printer completes sensor adjustment and the printer restarts.

*Quick Sensor Selection Method*  
(Transparent ↔ Reflective)  
(p.54)

### Adjusting the Reflective sensor

1. The reflective sensor is selected.
2. With the reflective sensor selected, install the label media so that it is between the platen roller and the media sensor.  
**Be careful that black mark and media gap do not pass the media sensor.** Then close the sensor arm and the printhead.

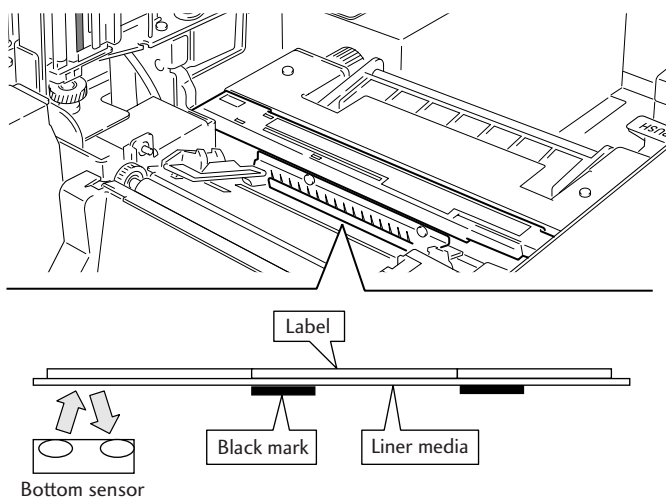

3. If the Pause Key is pressed then released while the MENU key is continually pressed, the sensor is automatically adjusted.

Sensor Cal Mode  
Executing

4. When automatic adjustment stops normally, "Succeeded" is displayed by the LCD. If it stops abnormally (adjustment is impossible), ERROR LED flashes and "Failed" is displayed on the LCD.

Sensor Cal Mode  
Succeeded

5. If the Cancel (STOP) key is pressed, the Printer completes sensor adjustment and the printer restarts.



*Installing the Media*  
(p.25, p.27)

*Self Print Mode* (p.36)

*Self Print Mode* (p.36)

## Media Thickness Adjustment

The printer is already factory-set to the requirements of proper print quality while using the recommended labels. If the print quality is inferior because of the different type of media, adjust the printhead position in the following manner:

### When using standard labels, or thermal media

1. Looking in at the media thickness check window, reset the printhead offset so that it comes to the center line (middle of the three lines) by turning the media thickness adjustment screw with a screwdriver.

Then turn the media thickness adjustment screw two to four times counterclockwise with a screwdriver. (Factory setting: two turns.)

2. Make fine adjustments by checking the self-test print.

### When using thick media (tags or other media)

1. Looking in at the media thickness check window, reset the printhead position so that it comes to the center line (middle of the three lines) by turning the media thickness adjustment screw with a screwdriver.

2. Then turn the media thickness adjustment screw two to four times clockwise with a screwdriver.

3. Make fine adjustments by checking the self-test print.

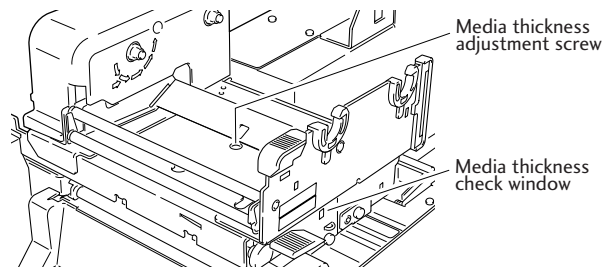

The relationship between the printhead heating element and the media thickness check window is shown below:

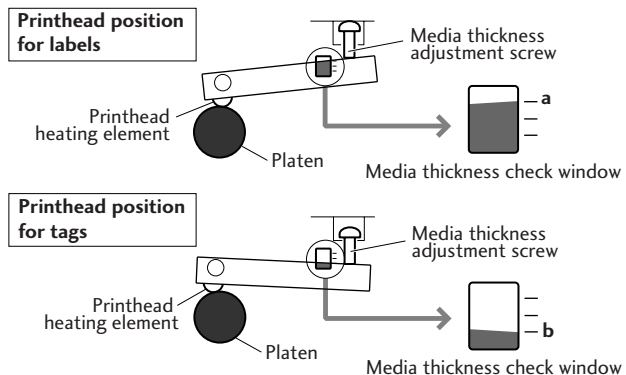

*Installing the Media*  
(p.25, p27)

*Self Print Mode* (p.36)

## Media Width Adjustment

The printer is already factory-set to the value of media width: 112 mm (4.4 in). When you use narrow media, adjust the printhead pressure in the following:

1. Looking in at the check window on the upper frame, align the mark (the left end of white plastic) with the width of media by turning the media width adjustment knob. (The printhead must be closed.)
2. Make fine adjustments by checking the self-test print.

**When the print on right side is too light:**

Move the mark (white) to the right side by turning the media width adjustment knob clockwise.

**When the print on the left side is too light:**

Move the mark to the left side by turning the media width adjustment knob counterclockwise.

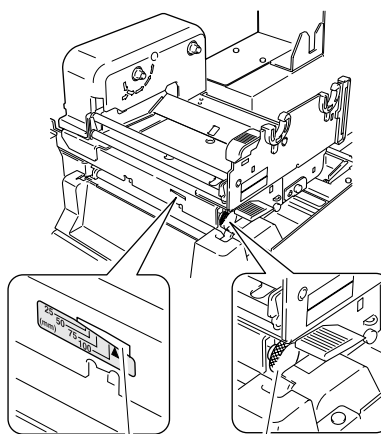

Media width check window

Media width adjustment knob

Check window	Width of media	
	mm	in
	25.4 mm	1 in
	50.8 mm	2 in
	76.2 mm	3 in
	101.6 mm	4 in
	When ribbon wrinkles or media screws with media width of 4 in or more	
	Factory setting	

Setting the Ribbon (p.32)

## Adjusting the Ribbon

Ribbon tension in this printer is already adjusted for the recommended ink ribbon and media and is very tolerant to different types of media. However, it may slip due to imperfect combinations of ribbon and media and it is possible that you will see a “Ribbon End” message even though the ribbon is not finished. This is more likely to happen with narrow width ribbons, especially those less than 50mm (2 inches).

To resolve this problem and obtain the optimum printing condition, make adjustments in the following manner (this should be done after the printhead pressure adjustments on the previous page are made):

### Adjusting Places

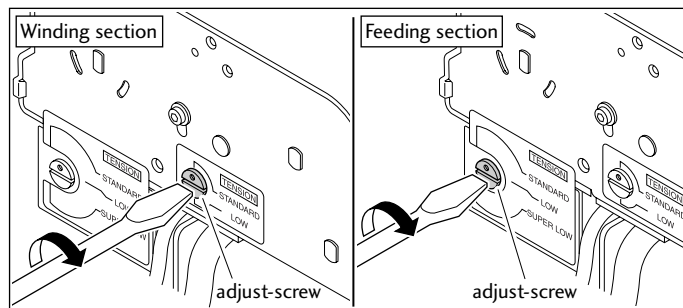

When turning adjust-screw, use a flat-tip screwdriver.

### Adjusting Method

#### 1. General ribbon and media

Factory setting: both marks on winding and feeding sections are set to STANDARD so as to obtain the optimum printing condition for the recommended ink ribbon and media.

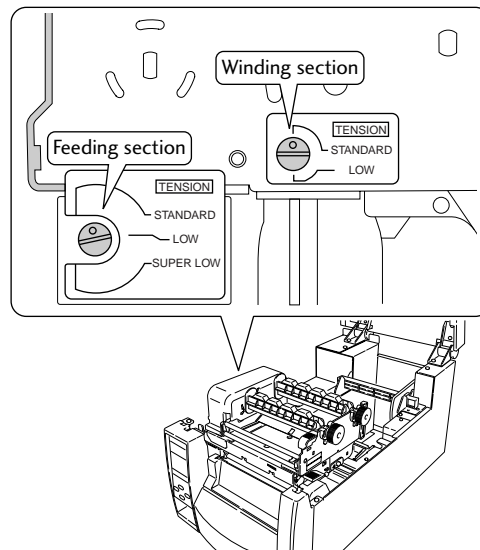

### 2. Easy-to-slip ribbon and media

If a message 'Ribbon Out' is shown, set the mark on the feeding section to LOW by turning the adjust-screw.

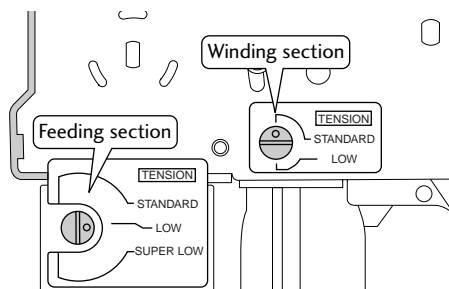

### 3. Especially-easy-to-slip ribbon and media

If a message 'Ribbon Out' is still shown, although Step 2 has been performed, set the mark on the feeding section to SUPER LOW by turning the adjust-screw.

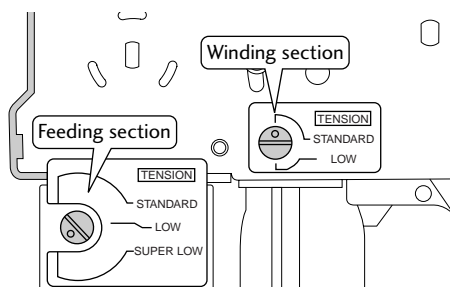

### 4. When ribbon is broken during printing

Ribbon may be broken if it is narrow in width and printhead heat temperature is high. In that case, set the mark on the feeding section to SUPER LOW and set the mark on the winding section to LOW by turning adjust-screw respectively.

**Note:** If the problem is still not resolved, please contact our service personnel.

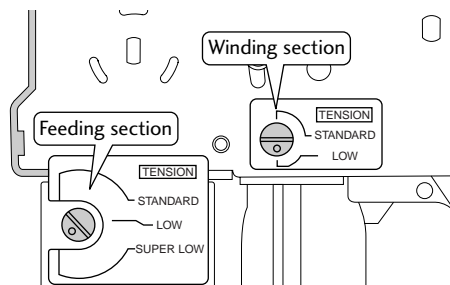

## Moving the Adjustable Sensor

### Operating procedure

*Menu Setting Table (p.43)  
Ensure the adjustable sensor  
is selected.*

Measure your required detection position beforehand, using the scale on the upper guide rail. Move the adjustable sensor to the required detection position by tuning the adjustable knob; it is useful to align the yellow mark on the top of the adjustable sensor with the scale showing the required detection position.

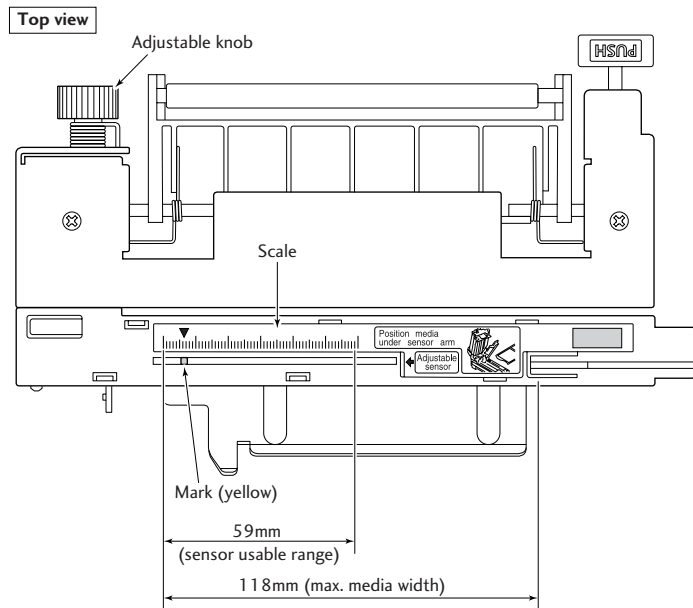

## Cleaning

Wipe off any foreign objects such as media dust, dirt and adhesive substances built up around the printhead and platen with the head cleaning pen (head cleaner) provided, and use a soft cloth soaked in ethyl alcohol for the platen etc.

It is particularly important to clean the thermal printhead after printing on thermal media for long periods, which will guarantee the print quality and extend the life of the thermal printhead.

**Note:** Always use the head cleaner when cleaning the thermal printhead.

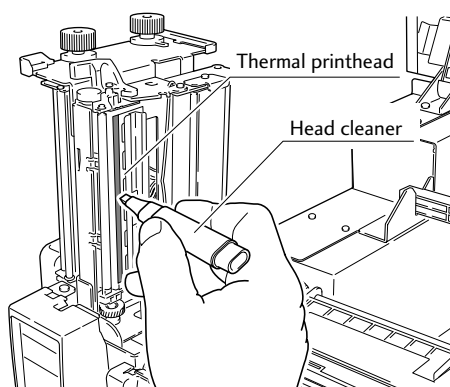

To clean the entire surface of the platen, rotate the platen little by little with your thumb using a cheese cloth. Do not touch the platen with your bare hands.

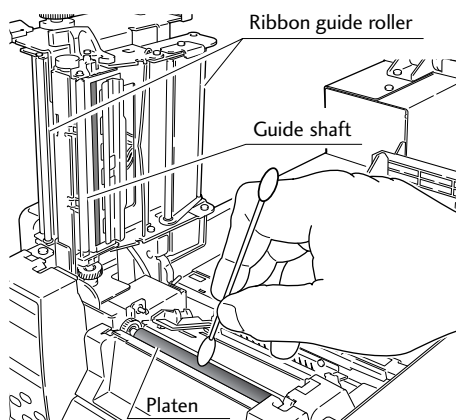

If the glue of the label media adheres to the roller, the peeled liner will stick and can cause a jam. Remove the glue adhered to the roller by using a cloth or something similar soaked in alcohol.

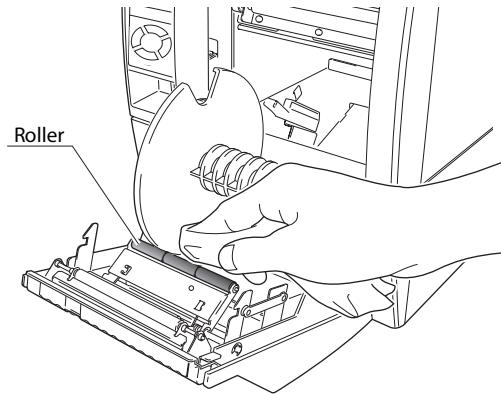

### **Caution**

Do not use any solvent other than ethyl alcohol. Solvents such as benzene, acetone and thinner will dissolve plastic parts and destroy the thermal printhead, platen and much of the printer!

Try to avoid using "excessive amounts" of ethyl alcohol to clean the platen. Excessive use will harden the platen surface prematurely.

# 4 Troubleshooting

This chapter explains corrective actions taken when the printer malfunctions or when an error message is displayed.

## Items to check when a malfunction occurs

When the printer malfunctions during operation, take corrective action with reference to the following table. If the corrective action does not solve the problem, consult with the service personnel at the dealer where you purchased the printer.

*Connection to Power (p.18)*

*Cleaning (p.62)*

*Setting the Ribbon (p.32)*

*Installing the Media (p.25, p27)*

*Setting method (p.32)*

*Menu Setting Table (p.43)*

*Cleaning (p.62)*

Indication	Check	Corrective action
The LED do not light up when printer power is connected.	1) Is the plug of the power cord correctly inserted into the electric outlet?	1) Insert the plug of the power cord correctly in the electric outlet.
	2) Is the connector of the power cord correctly inserted into the power inlet of the printer?	2) Insert the connector of the power cord correctly into the power inlet of the printer.
	3) Is the power cord damaged?	3) Replace the power cord. Consult with the dealer where the printer was purchased to make sure you obtain a cord made especially for the printer. <b>Note:</b> Do not use any power cord except one made especially for the printer.
	4) Is power supplied to the electric outlet the printer is connected to?	4) Check to make sure power is supplied to the outlet. If there are any problems, make sure power is supplied to the building. Or find out if a power failure has occurred.
	5) Is the main fuse in the building's fuse box burnt out?	5) If necessary, replace the main fuse in the building's fuse box, and reset the main breaker. Ask a qualified serviceman to carry out the replacement.
Paper is feeding, but nothing is printed.	1) Is the thermal printhead dirty? Is a label stuck to the head?	1) If it is dirty, remove the dirt with the attached head cleaner. If a label is stuck to the thermal printhead remove it. <b>Note:</b> Do not use a metal object to remove a label stuck to the inside of the printer. (This may damage the thermal printhead.) If adhesive label material is stuck to the thermal printhead, remove it with a soft cloth soaked in ethyl alcohol.
	2) Is the recommended ribbon or a ribbon of the same type used?	2) Use the recommended ribbon or a ribbon of the same type.
The printer is not printing neatly.	1) Are the media and the ribbon correctly set?	1) Correctly set the media and the ribbon.
	2) Is the printing density too high or too low?	2) Set the appropriate printing density using the menu or control software.
	3) Is the platen dirty? Is it deformed?	3) If it is dirty, clean it with ethyl alcohol. If it is deformed, replace it. <b>Note:</b> Consult with the dealer that supplied the printer concerning the replacement.



*Setting the Ribbon  
(p.32)*

*Media Thickness  
Adjustment (p.57)*

*Media Width  
Adjustment (p.58)*

*Installing the Media  
(p.25, P27)*

*Setting method (p.32)  
Cleaning (p.62)*

*LED Functions (p.22)*

*Menu Setting Table  
(p.43)*

*Adjusting the Ribbon  
(p.59)*

*Adjusting the Ribbon  
(p.59)*

*Setting the Ribbon  
(p.32)*

Indication	Check	Corrective action
The printer is not printing neatly.	4) Is the thermal printhead dirty? Is a label stuck to the head.	4) If it is dirty, remove the dirt with the attached head cleaner. If a label is stuck to the head, remove it. <b>Note:</b> Do not use a metal object to remove a label stuck to the inside of the printer. (This may damage the thermal printhead.) If adhesive label material is stuck to the print head, remove it with a soft cloth soaked in ethyl alcohol.
	5) Is the recommended ribbon or a ribbon of the same type used?	5) Use the recommended ribbon or a ribbon of the same type.
	6) Is the thermal printhead in the correct position for the media that is used?	6) Adjust the offset of the thermal printhead with the media thickness adjustment dial.
	7) Is the printer's head pressure balance correct for the width of the media that is used?	7) Adjust the thermal printhead pressure with the media width adjustment dial.
The printing position changes.	1) Are the media and the ribbon correctly set?	1) Correctly set the media and the ribbon.
	2) Is the platen dirty? Is it deformed?	2) If it is dirty, clean it with ethyl alcohol. If it is deformed, replace it. <b>Note:</b> Consult with the dealer that supplied the printer concerning the replacement.
	3) Are the data contents and the command signals from the host appropriate?	3) If an error message is displayed, check the content of the software and the communication status set by the host computer.
	4) Are the menu values set appropriately?	4) Set the correct menu values using the operating panel or the host computer.
	5) Are the sensitivities of the media sensors appropriate for the media that is used?	5) Set the media sensitivity to appropriate values. If this does not solve the problem, change the "Sensor level" that is set in the "System setup."
The ribbon is wrinkled	1) Is the ribbon tension suitable for the ribbon that is used?	1) Adjust the tension with the adjust-screw.
	2) Is the ribbon used correctly balanced to the right and left?	2) Adjust the left - right balance with the media width adjustment knob.
	3) Is the printing density too high?	3) Set the appropriate printing density using the menu or control software.
	4) Are the media and ribbon the recommended products or equivalent products?	4) Use the recommended products or equivalent products. If this does not correct the problem, contact a service representative.
The ribbon slips (ribbon dirt is produced.)	1) Is the ribbon tension suitable for the ribbon that is used?	1) Adjust the tension with the adjust-screw.
The ribbon does not wind.	1) Is the ribbon set in the correct course?	1) Set the ribbon in the correct course.
	2) Is the ribbon winding direction reversed?	2) Set the correct winding direction.

# Appendixes

## Specifications

Item	Description			
Printing	Printing method	Thermal transfer/Direct thermal		
	Resolution	Main scanning line density: 203 dots/inch (8 dots/mm) (7010/7010R) 300 dots/inch (11.8 dots/mm) (7010-300)		
		Sub-scanning line density: 203 dots/inch (8 dots/mm) (7010/7010R) 300 dots/inch (11.8 dots/mm) (7010-300)		
		Head 864 dots (printable dots: 832 dots) (7010/7010R) 1275 dots (printable dots: 1240 dots) (7010-300)		
	Max. print width	104 mm (7010/7010R) 105 mm (7010-300)	4.1 inch (7010/7010R) 4.1 inch (7010-300)	
	Max. print length	812.8 mm	32 inch	
	Print density	Print density is adjustable with software		
Printing speed	Printing speed setting	2 - 10 inches per second (7010/7010R) 2 - 8 inches per second (7010-300) • 2-7 inches per second for 7010/7010R with optional peeler.		
Print mode	Batch mode	Normal printing (single or multiple sheets)		
	Tear off mode	Feeds back media to the tear-off position after printing is completed.		
	Cut mode <sup>*1</sup>	Prints while cutting at designated sheet units. The following two kinds of cut mode operations are done. • Backfeed • Cut through (Cut through refers to stopping part-way through printing the 'next label' to make the cut. After cutting, printing restarts but there is a chance of a small gap or mark at the temporary stop position.)		
	Peel mode <sup>*2</sup>	Peels labels from the liners after printing them.		
Media	Types of media	Roll, fanfold (continuous media, die-cuts, continuous tags, paper or tickets)		
	Recommended media	Thermal transfer: label media (RPR-W Ricoh) Direct thermal media: label media (150LA-1 Ricoh), tag media (TB2E0V, Mitsubishi Paper)		
	Max. media width	18.0 mm	4.65 inch	
	Min. media width	25.4 mm	1.00 inch	
	Min. label width	7.62 mm	0.30 inch	
	Min. label pitch <sup>*3</sup>	6.35 mm	0.25 inch	
	Max. media thickness	0.254 mm	0.01 inch	
	Max. media length	812.8 mm	32 inch	
	Min. media length	6.35 mm	0.25 inch	
	Min. media thickness	0.0635 mm	0.0025 inch	
	On-board roll media diameter	Max. outside diameter: 203mm	8 inch	
		Media core: 38 to 76 mm	1.5 to 3 inch	
	Rewinding roll media diameter (7010R only)	Media core: 26, 40, 45 mm	1.02, 1.57, 1.77 inch	
	Ribbon	Recommended ribbon	B110A Ricoh	
		Max. ribbon width	14.0 mm	4.50 inch
Min. ribbon width		25.4 mm	1.00 inch	
Max. ribbon length		450.0 m	1,476 ft	
Max. roll diameter		86.5 mm	3.40 inch	
Inner diameter of the paper core		25.4 ± 0.25 mm	1.00 ± 0.01 inch	
Ribbon end tape length		Max. 80.0 mm	3.15 inch	
Ribbon end detection		Ribbon out is detected by the ribbon sensor		

Item		Description
Bar code (for Datamax® emulation)	One-dimension	<ul style="list-style-type: none"> <li>• Code 3 of 9 • UPC-A • UPC-E • EAN-13 (JAN-13)</li> <li>• EAN-8 (JAN-8) • Interleaved 2 of 5 • Code 128</li> <li>• HIBC (Modulus 43-used code 3 of 9) • Codabar (NW-7)</li> <li>• Int 2 of 5 (Modulus 10-used Interleaved 2 of 5) • Plessey</li> <li>• Case Code • UPC 2DIG ADD • UPC 5DIG ADD</li> <li>• Code 93 • Telepen • ZIP • UCC/EAN128</li> <li>• UCC/EAN128 (for K-MART)</li> <li>• UCC/EAN128 Random Weight • FIM</li> </ul>
	Two-dimension	UPS Maxi Code, PDF-417, Data Matrix, QR Code, Aztec, RSS
Bar code (for Zebra® emulation)	One-dimension	<ul style="list-style-type: none"> <li>• Code 11 • Interleaved 2 of 5 • Code 39 • EAN-8 • UPC-E • Code 93</li> <li>• Code 128 • EAN-13 • Industrial 2 of 5 • Standard 2 of 5</li> <li>• ANSI CODABAR • LOGMARS • MSI • Plessey • UPC/EAN Extensions</li> <li>• UPC-A • POSTNET • Planet</li> </ul>
	Two-dimension	<ul style="list-style-type: none"> <li>• Code 49 • PDF-417 • CODA BLOCK • UPS Maxi Code</li> <li>• Micro PDF-417 • Data Matrix • QR Code • RSS • TLC39</li> </ul>
Font (for Datamax® emulation)		<ol style="list-style-type: none"> <li>1. Seven kinds of fixed pitch font <ul style="list-style-type: none"> <li>• Overseas, English fonts and European fonts</li> </ul> </li> <li>2. OCR fonts OCR-A<sup>4</sup>, OCR-B<sup>4</sup></li> <li>3. Proportional fonts <ul style="list-style-type: none"> <li>CG Triumvirate smooth font</li> <li>CG Triumvirate Bold smooth font</li> <li>(6, 8, 10, 12, 14, 18, 24, 30, 36, 48 points) (7010/7010R)</li> <li>(4, 5, 6, 8, 10, 12, 14, 18, 24, 30, 36, 48 points) (7010-300)</li> <li>• Character set: Conforms with code page 850 standards</li> </ul> </li> <li>4. True type™ rasterizer<sup>5</sup></li> </ol>
Font (for Zebra® emulation)		<ol style="list-style-type: none"> <li>1. Five kinds of fixed pitch font <ul style="list-style-type: none"> <li>• Overseas, English fonts and European fonts</li> </ul> </li> <li>2. OCR fonts <ul style="list-style-type: none"> <li>OCR-A, OCR-B</li> </ul> </li> <li>3. Proportional font <ul style="list-style-type: none"> <li>CG Triumvirate Condensed Bold</li> </ul> </li> <li>4. True type™ rasterizer<sup>5</sup></li> </ol>
Symbol set		PC866U Ukraina <sup>6</sup> , PC Cyrillic, ISO 60 Danish/Norwegian, DeskTop, ISO 8859/1 Latin 1, ISO 8859/2 Latin 2, ISO 8859/9 Latin 5, ISO 8859/10 Latin 6, ISO 8859/7 Latin/Greek, ISO 8859/15 Latin 9, ISO 8859/5 Latin/Cyrillic, ISO 69: French, ISO 21: German, ISO 15: Italian, Legal, Math-8, Macintosh, Math, PC-858 Multilingual, Microsoft Publishing, PC-8, Code Page 437, PC-8 D/N, Code Page 437N, PC-852 Latin 2, PC-851 Latin/Greek, PC-862 Latin/Hebrew, Pi Font, PC-850 Multilingual, PC-864 Latin/Arabic, PC-8 TK, Code Page 437T, PC-1004, PC-775 Baltic, Non-UGL, Generic Pi Font, Roman-8, Roman-9, ISO 17: Spanish, ISO 11: Swedish, Symbol, PS Text, ISO 4: United Kingdom, ISO 6: ASCII, Ventura International, Ventura Math, Ventura US, Windows 3.1 Latin 1, Windings, Windows 3.1 Latin 2, Windows 3.1 Baltic (Latv, Lith), Windows 3.0 Latin 1, Windows Latin/Cyrillic, Windows 3.1 Latin 5
Control language		Conforms to Datamax® programming language <sup>7</sup> and Zebra® programming language <sup>8</sup>
Outline of electronic devices	CPU	32Bit RISC CPU
	ROM	Standard equipment: FLASH ROM 4MBytes (User area: 1MByte)
	RAM (for Datamax® L.)	Standard equipment: SDRAM 16MBytes (User area: 1MByte)
	RAM (for Zebra® L.)	Standard equipment: SDRAM 16MBytes (User area: 4MByte)

# Appendixes

## Specifications

Item	Description	
Media detection sensors	Transparent sensor	Detects media gap between labels, notches on tags, and media out
	Reflective sensor	Detects reflective mark on back of media and media out
	Label peeling sensor <sup>1</sup>	
Communication interfaces	Parallel <sup>9</sup>	IEEE1284 (compatible, Nibble, ECP mode)
	Serial	2400 4800 9600 19200 38400 57600 115200bps
	USB	FULL Speed USB1.1
Communication interface options	Network	Wired ethernet (10-BASE-T/ 100-BASE-TX) or Wireless LAN
Indications and switches	LCD	128 X 64 dots, STN graphic type
	LED	POWER, ERROR
	Buzzer	Alarms, errors, etc.
	Operating panel keys	PAUSE, FEED, STOP, MENU
	Head-up detection sensor	Detects head open
	Power switch	Turns power on and off
	Acoustic noise	55 dB (by EN ISO7779)
Power (standards)	100-240V (-10%+6%), 3.5-1.5A, 50/60Hz	
	U.S.A./Canada: UL 60950-1, CSA No.950, FCC Part15 SubpartB (ClassA)	
	Europe: EN 60950-1, EN 55022 (ClassA), EN 55024, EN 61000-3-2, EN 61000-3-3	
Environment	Operating temperature conditions:	Operating temp. 0 to 40°C, humidity 30 to 80%, condensation free (Conditions: ventilation, and natural convection)
	Storage temperature conditions:	Temp. -20 to 60°C, humidity 5 to 85% (Conditions: ventilation, and natural convection)

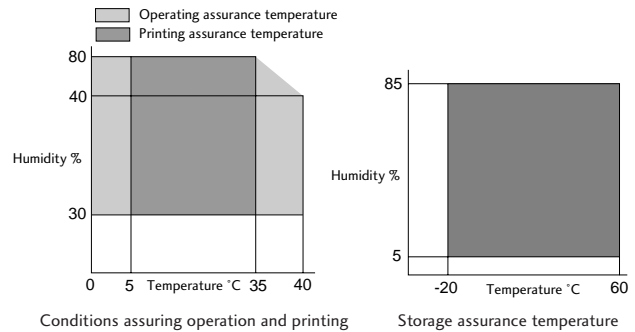

External dimensions  
(for 7010/7010-300)

Approx. 255(W) X 490 (D) X 265 (H) mm  
10(W) X 19.3 (D) X 10.4 (H) inch

Unit: mm (inch)

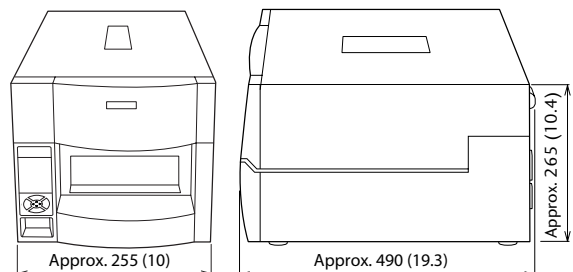

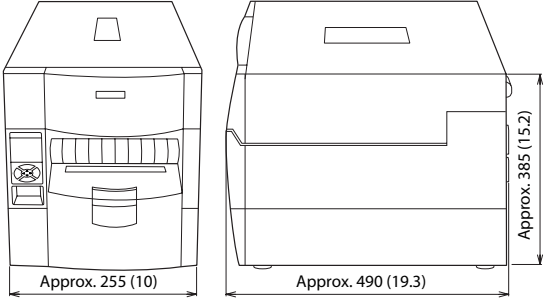
Item	Description
External dimensions (for 7010R)	<p>Approx. 254 (W) X 480 (D) X 375 (H) mm 10 (W) X 18.9 (D) X 14.8 (H) inch</p> <p>Unit: mm (inch)</p> 
Weight	<p>Approx. 13.3 kg (29.3 lb.) (for 7010/7010-300) Approx. 17.6 kg (38.7 lb.) (for 7010R)</p>
Accessories	<p>Test label media, Test ribbon, CD-ROM (User Guide), Quick Start Guide, Head cleaner, Power cord, Media holder bar and Media holder guide, Ribbon holder, Paper core</p>
Option	<p>Auto-cutter unit, Peeler unit, Ethernet interface and Rewinder kit</p>

\*1, \*2: Options can be separately purchased.

\*3: When a media pitch of less than 1 inch is used, activate the "Small Label Printing" setting in the "Printing Setting."

\*4: The OCR font may have a low recognition rate according to the reader.

\*5: It is equipped with UFST™ and TrueType™ rasterizer that are licensed from Agfa Corporation. TrueType™ is a trademark of Apple Computer.

UFST™ and TrueType™ rasterizer are licensed from Agfa Corporation.

UFST™ is a trademark of Agfa Corporation. TrueType™ is a trademark of Apple Computer.

\*6: "PC866U Ukraina" is available for Datamax® emulation only.

\*7: Datamax® is a registered trade mark of Datamax Bar Code Products Corporation.

\*8: Zebra® is a registered trade mark of ZIH corp.

\*9: This interface is Non-L. P. S. (Limited Power Source).

## Interfaces

This printer is connected to a computer and prints according to commands sent from the computer.

There are three types of computer interfaces, and these are connected to devices suited to each type of interface. The printer can also be connected to a computer by the optional Ethernet.

### Serial Interface

#### Specifications

System	Start/stop asynchronous duplex communication
Signal level	RS-232C
Baud rate	2400, 4800, 9600, 19200, 38400, 57600, 115200bps
Bit length	7Bit, 8Bit
Stop bit	1Bit, 2Bit
Parity	Odd, even, none
Connector	D-SUB 25PIN

#### Signal line and pin arrangement

Pin No.	Signal code	Signal name	Function
1	FG	Protective grounding	Protective grounding
2	TXD	Transmitted data	Signal line that transmits data from the printer to other devices
3	RXD	Received data	Signal line that transmits data from other devices to the printer
4	RTS	Transmission request	Pull up to +5.4V through 3.3k $\Omega$
5	NC	-----	Not used
6	DSR	Data set relay	Signal line that is active when an external device can interface with the printer
7	SGND	Signal line ground	Shows the ground level of the signal line
8-13	NC	-----	Not used
14	VCC	+5V	(FACTORY USE ONLY )
15-19	NC	-----	Not used
20	DTR	Data terminal relay	Signal line that is active when an external device can interface with the printer
21-25	NC	-----	Not used

### XON/XOFF Protocol

#### Requirements to output X-ON code

- Communication is possible when the power is on.
- When the receive buffer has less than 128 bytes available, XOFF code is output, then the receive buffer has at least 1024 bytes available.

#### Requirements to output the X-OFF code

- When the receive buffer has less than 128 bytes available

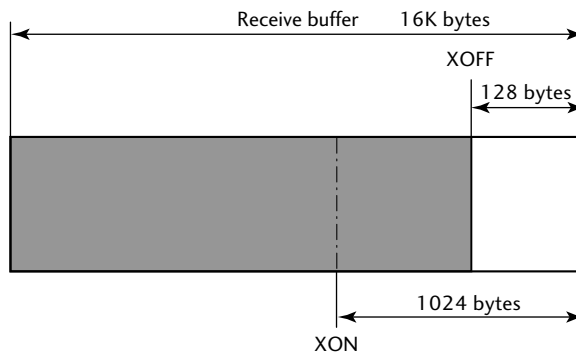

### DTR Protocol

#### Conditions when the DTR signal is “Ready (High)”

All the following conditions are satisfied.

- The receive buffer is 128 bytes or more available capacity.
- \* When the receive buffer has less than 128 bytes available and the DTR signal has changed to BUSY (Low) status, BUSY status is maintained until the capacity of the receive buffer has reached 1024 bytes or more.

#### Conditions when DTR signal is “Busy (Low)”

- When the receive buffer has fallen to less than 128 bytes available.

### Parallel Interface

#### Specifications

Transmission mode	8-bit parallel data
Receive buffer size	16K bytes
Transmission modes	<p><b>Compatible mode</b> It is an asynchronous forward direction of the byte width (from host to printer) channel, and the interface line of the data is operated in accordance with signal line definitions of Centronics.</p> <p><b>NIBBLE mode</b> Nibble mode is asynchronous reverse channel communication with data transmission controlled by the host computer. In reverse channel transmission, the data is nibble transmitted in two parts using four status lines (Fault, Select, PE, and Busy). And nibble mode can be used along with compatible mode to send data in two directions.</p> <p><b>ECP mode</b> ECP mode permits bi-directional asynchronous data transmission, and thanks to its interlock handshake, it does not require the timing necessary with compatible mode.</p>
Signal level	IEEE1284 standard

#### Signal line and pin assignment table

Pin No.	Signal name	I/O	Function
1	*STROBE	Input	Strobe signal to read in 8-bit data
2-9	DATA1 -8	Input	8-bit parallel signal
10	*ACKNLG	Output	8-bit data request signal
11	BUSY	Output	Signal specifying printer busy
12	PERROR	Output	Signal specifying media out
13	SELECT	Output	Signal specifying if the printer is on-line (printing enabled) or off-line (pausing)
14	AUTOFD	Input	Invalid (ignored)
15	NC	---	Not used
16	GND	---	Signal ground
17	FGND	---	Frame ground
18	P.L.H	Output	Peripheral logic high (pull up to +5V at 1k $\Omega$ )
19-30	GND	---	Ground for twisted pair return
31	*INIT	Input	Printer reset
32	*FAULT	Output	Signal specifying printer error
33-35	NC	---	Not used
36	SELECTIN	Input	Invalid (ignored)



**Parallel port status signals when an error occurs**

The status of a signal line will not be changed in bi-directional mode such as nibble or ECP mode.

Error	Change in the status of a signal line in compatible mode
Paper end	Busy : L → H PError : L → H Select : H → L nFault : H → L
Error other than paper end • Head open • Other	Busy : L → H PError : L → unchanged Select : H → L nFault : H → L
Conditions for Busy	<ul style="list-style-type: none"> <li>• Receive buffer full</li> <li>• Data being read</li> <li>• Error</li> </ul>

**Compatible timing specification**

[When power is on] (Time it goes off-line)

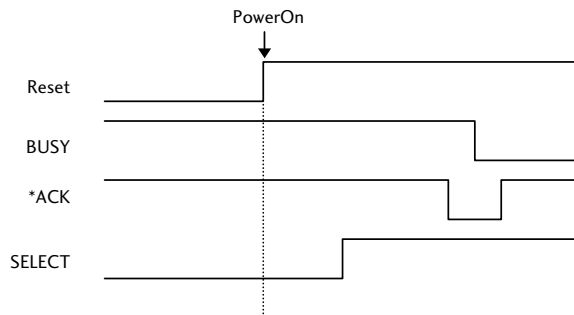

[While receiving data]

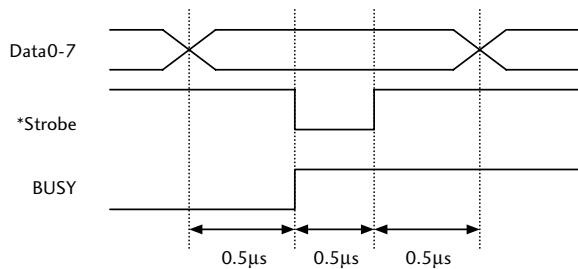

**Note:** Busy rises when \*Strobe signal starts, and data is latched with \*Strobe signal starts.

### [While receiving INIT signal]

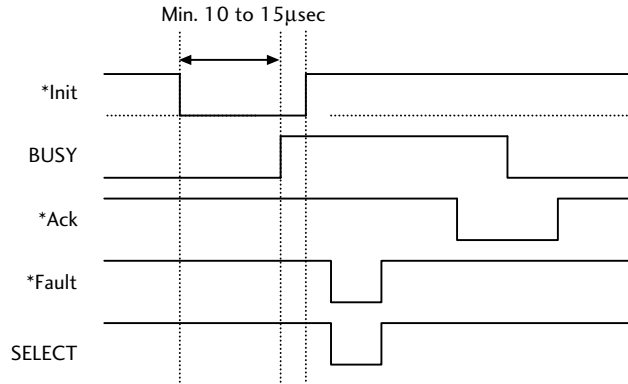

**Note:** If the \*Init signal does not have width of 10 to 15µsec or more, it cannot act as an Init signal. If it is lower, the \*Init signal is ignored. BUSY starts up when the \*Init signal is perceived.

### Relation of the timing of the BUSY signal and the \*ACK signal [Center – ACK]

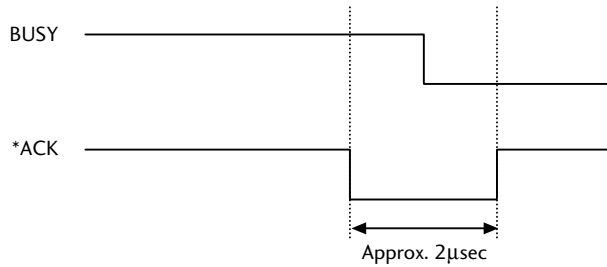

## USB Interface

### Specifications

Standards	Complies with Universal Serial Bus Specification
Transmission speed	Compatible with 12Mbps (full speed) transmission
Receive buffer	16K bytes
Connector	DUSB DUSB-BRA42-T11 (DDK)

### Signal line and pin arrangement

Pin No.	Signal code	Signal	Function
1	VBUS	USB power	USB power (+5V)
2	D+	Signal line +	+ signal line
3	D-	Signal line -	- signal line
4	GND	GND	GND

## Replacing the Interface Board

### Caution

Always turn off the power to the printer before replacing the interface board. Do not pull it out with unnecessary force. This will cause an accident.

### Replacement Method

1. Remove the screws (2) that anchor the bracket of the interface board then pull the interface board towards you. When you do this, be careful not to perform any unreasonable operations that will damage the connecting cable and do not pull the cable too much. If you do, it will cause a malfunction.

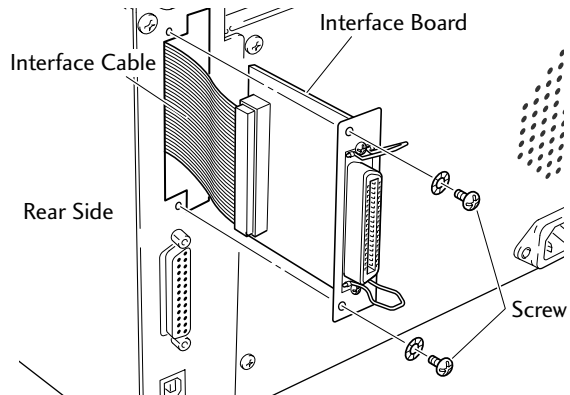

2. Remove the connecting cable from the interface board and reconnect the cable to the connector of the replacement interface board

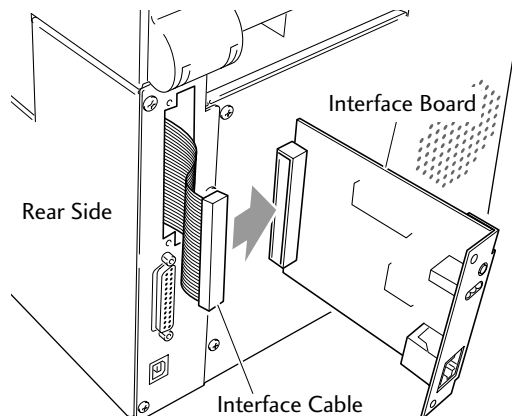

### Replacing the Interface Board

3. Insert the interface board into the printer so that the connecting cable does not catch on the printer, then use the screws (2) that you removed to anchor the bracket.

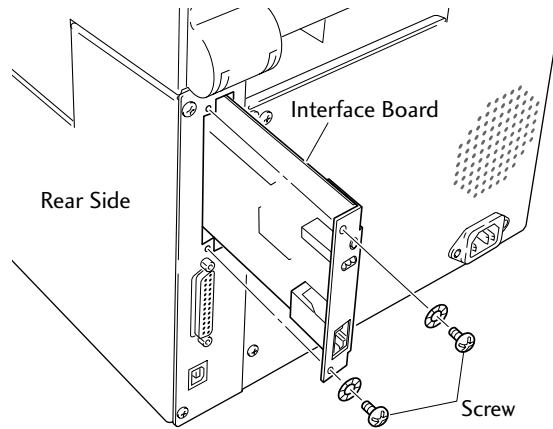

## Replacing the Print Head



### Caution

- Carefully handle the Print Head when disassembling and reassembling so as not to damage the thermal elements of the Print Head. Especially, avoid contacting the thermal elements with the metal part, etc.
- Ensure to use a Phillips Screwdriver for Japanese norm "PH2", especially for Japanese screws, length >200mm

The Unit, Head can be removed easily without detaching any other parts.

1. Open the top cover.
2. Open the head block by pushing the head open lever.
3. While holding the Unit, Head, turn the screw until the Unit, Head comes off.
4. Remove the SA, Head Cable from the Unit, Head.

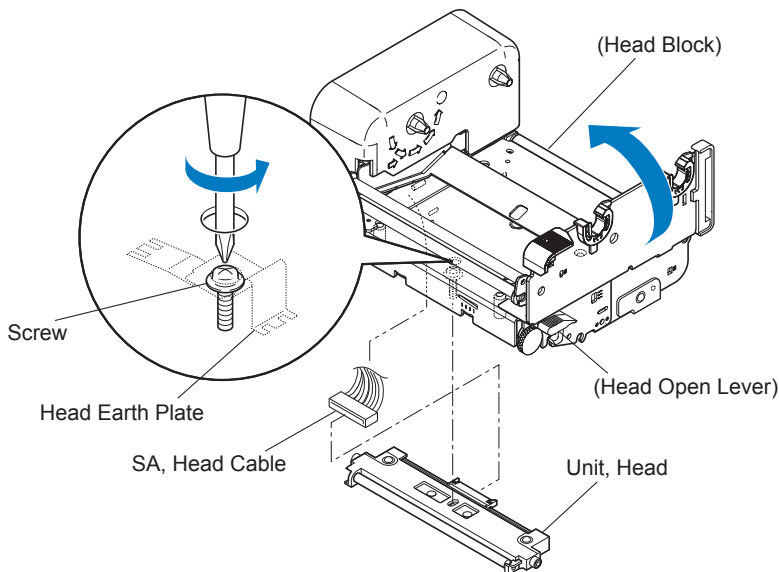

### **Notes on reassembling:**

- When attaching the Unit, Head, do not strongly push it against the head block. The Head Earth Plate may come off if you push the Unit, Head strongly.
- Securely fasten the Unit, Head with the screw.
- When you replace the Unit, Head with a new one, adjust the angle of head spacer shaft, if ribbon wrinkles are not removed. (This adjustment will be required only when satisfactory results are not obtained by adjusting the ribbon tension with the adjusting screws of the Ribbon Unit.

# WEEE MARK

**En** If you want to dispose this product, do not mix with general household waste. There is a separate collection systems for used electronics products in accordance with legislation under the WEEE Directive (Directive 2002/96/EC) and is effective only within European Union.

**Ge** Wenn Sie dieses Produkt entsorgen wollen, dann tun Sie dies bitte nicht zusammen mit dem Haushaltsmüll. Es gibt im Rahmen der WEEE-Direktive innerhalb der Europäischen Union (Direktive 2002/96/EC) gesetzliche Bestimmungen für separate Sammelsysteme für gebrauchte elektronische Geräte und Produkte.

**Fr** Si vous souhaitez vous débarrasser de cet appareil, ne le mettez pas à la poubelle avec vos ordures ménagères. Il existe un système de récupération distinct pour les vieux appareils électroniques conformément à la législation WEEE sur le recyclage des déchets des équipements électriques et électroniques (Directive 2002/96/EC) qui est uniquement valable dans les pays de l'Union européenne.

Les appareils et les machines électriques et électroniques contiennent souvent des matières dangereuses pour l'homme et l'environnement si vous les utilisez et vous vous en débarrassez de façon inappropriée.

**Sp** Si desea deshacerse de este producto, no lo mezcle con residuos domésticos de carácter general. Existe un sistema de recogida selectiva de aparatos electrónicos usados, según establece la legislación prevista por la Directiva 2002/96/CE sobre residuos de aparatos eléctricos y electrónicos (RAEE), vigente únicamente en la Unión Europea.

**It** Se desiderate gettare via questo prodotto, non mescolatelo ai rifiuti generici di casa. Esiste un sistema di raccolta separato per i prodotti elettronici usati in conformità alla legislazione RAEE (Direttiva 2002/96/CE), valida solo all'interno dell'Unione Europea.

**Du** Deponeer dit product niet bij het gewone huishoudelijk afval wanneer u het wilt verwijderen. Er bestaat ingevolge de WEEE-richtlijn (Richtlijn 2002/96/EG) een speciaal wettelijk voorgeschreven verzamelsysteem voor gebruikte elektronische producten, welk alleen geldt binnen de Europese Unie.

**Da** Hvis du vil skille dig af med dette produkt, må du ikke smide det ud sammen med dit almindelige husholdningsaffald. Der findes et separat indsamlingssystem for udtjente elektroniske produkter i overensstemmelse med lovgivningen under WEEE-direktivet (direktiv 2002/96/EC), som kun er gældende i den Europæiske Union.

**Por** Se quiser deitar fora este produto, não o misture com o lixo comum. De acordo com a legislação que decorre da Directiva REEE – Resíduos de Equipamentos Eléctricos e Electrónicos (2002/96/CE), existe um sistema de recolha separado para os equipamentos electrónicos fora de uso, em vigor apenas na União Europeia.

**Pol** Jeżeli zamierzasz pozbyć się tego produktu, nie wyrzucaj go razem ze zwykłymi domowymi odpadkami. Według dyrektywy WEEE (Dyrektywa 2002/96/EC) obowiązującej w Unii Europejskiej dla używanych produktów elektronicznych należy stosować oddzielne sposoby utylizacji.



All rights reserved. Translations, reprinting or copying by any means of this manual complete or in part or in any different form requires our explicit approval. We reserve the right to make changes to this manual without notice. All care has been taken to ensure accuracy of information contained in this manual. However, we cannot accept responsibility for any errors or damages resulting from errors or inaccuracies of information herein.

For sales or technical support call **The Printer Place**

Tel.: +1 800 243 3338 [www.theprinterplace.com](http://www.theprinterplace.com)



