

PRINTRONIX® **PSA3**
P7000 User's Manual



READ THIS SOFTWARE LICENSE AGREEMENT BEFORE USING THIS PRINTER

Software License Agreement

CAREFULLY READ THE FOLLOWING TERMS AND CONDITIONS BEFORE USING THIS PRINTER. USING THIS PRINTER INDICATES YOUR ACCEPTANCE OF THESE TERMS AND CONDITIONS. IF YOU DO NOT AGREE TO THESE TERMS AND CONDITIONS, PROMPTLY RETURN THE PRINTER AND ALL ACCOMPANYING HARDWARE AND WRITTEN MATERIALS TO THE PLACE YOU OBTAINED THEM, AND YOUR MONEY WILL BE REFUNDED.

Definitions.

"Software" shall mean the digitally encoded, machine-readable data and program. The term "Software Product" includes the Software resident in the printer and its documentation. The Software Product is licensed (not sold) to you, and Printronix, Inc. either owns or licenses from other vendors who own, all copyright, trade secret, patent and other proprietary rights in the Software Product.

License.

1. Authorized Use. You agree to accept a non-exclusive license to use the Software resident in the printer solely for your own customary business or personal purposes.
2. Restrictions.
 - a. To protect the proprietary rights of Printronix, Inc., you agree to maintain the Software Product and other proprietary information concerning the typefaces in strict confidence.
 - b. You agree not to duplicate or copy the Software Product.
 - c. You shall not sublicense, sell, lease, or otherwise transfer all or any portion of the Software Product separate from the printer, without the prior written consent of Printronix, Inc.
 - d. You may not modify or prepare derivative works of the Software Product.
 - e. You may not transmit the Software Product over a network, by telephone, or electronically using any means; or reverse engineer, decompile or disassemble the Software.
 - f. You agree to keep confidential and use your best efforts to prevent and protect the contents of the Software Product from unauthorized disclosure or use.
3. Transfer. You may transfer the Software Product with the printer, but only if the recipient agrees to accept the terms and conditions of this Agreement. Your license is automatically terminated if you transfer the Software Product and printer.

Limited Software Product Warranty

Printronix, Inc. warrants that for ninety (90) days after delivery, the Software will perform in accordance with specifications published by Printronix, Inc. Printronix, Inc. does not warrant that the Software is free from all bugs, errors and omissions.

Remedy

Your exclusive remedy and the sole liability of Printronix, Inc. in connection with the Software is replacement of defective software with a copy of the same version and revision level.

Disclaimer of Warranties and Limitation of Remedies

1. THE PARTIES AGREE THAT ALL OTHER WARRANTIES, EXPRESS OR IMPLIED, INCLUDING WARRANTIES OF FITNESS FOR A PARTICULAR PURPOSE AND MERCHANTABILITY ARE EXCLUDED. Printronix, Inc. does not warrant that the functions contained in the Software will meet your requirements or that the operation of the Software will be uninterrupted or error free. Printronix, Inc. reserves the right to make changes and/or improvements in the Software without notice at any time.
2. IN NO EVENT WILL PRINTRONIX, INC. BE LIABLE FOR LOST PROFITS, LOST DATA, BUSINESS INTERRUPTIONS, OR ANY OTHER DIRECT, INDIRECT, INCIDENTAL OR CONSEQUENTIAL DAMAGES ARISING OUT OF THE USE OF OR INABILITY TO USE THIS PRODUCT, EVEN IF PRINTRONIX, INC. HAS BEEN ADVISED OF THE POSSIBILITY OF SUCH DAMAGES, OR ANY DAMAGES CAUSED BY THE ABUSE OR MANIPULATION OF THE SOFTWARE. SOME STATES DO NOT ALLOW THE EXCLUSION OR LIMITATION OF LIABILITY FOR CONSEQUENTIAL OR INCIDENTAL DAMAGES, SO THE ABOVE LIMITATION MAY NOT APPLY TO YOU.
3. Printronix, Inc. will not be liable for any loss or damage caused by delay in furnishing a Software Product or any other performance under this Agreement.
4. Our entire liability and your exclusive remedies for our liability of any kind (including liability for negligence except liability for personal injury caused solely by our negligence) for the Software Product covered by this Agreement and all other performance or nonperformance by us under or related to this Agreement are limited to the remedies specified by this Agreement.
5. California law governs this Agreement.

Termination of License Agreement

This License shall continue until terminated. This license may be terminated by agreement between you and Printronix, Inc. or by Printronix, Inc. If you fail to comply with the terms of this License and such failure is not corrected within thirty (30) days after notice. When this License is terminated, you shall return to the place you obtained them, the printer and all copies of the Software and documentation.

U.S. Government Restricted Rights

Use, duplication or disclosure by the Government is subject to restrictions as set forth in the Rights in Technical Data and Computer Software clause at FAR 242.227-7013, subdivision (b) (3) (ii) or subparagraph (c) (1) (ii), as appropriate. Further use, duplication or disclosure is subject to restrictions applicable to restricted rights software as set forth in FAR 52.227-19 (c) (2).

Acknowledgement of Terms and Conditions

YOU ACKNOWLEDGE THAT YOU HAVE READ THIS AGREEMENT, UNDERSTAND IT, AND AGREE TO BE BOUND BY ITS TERMS AND CONDITIONS. NEITHER PARTY SHALL BE BOUND BY ANY STATEMENT OR REPRESENTATION NOT CONTAINED IN THIS AGREEMENT. NO CHANGE IN THIS AGREEMENT IS EFFECTIVE UNLESS WRITTEN AND SIGNED BY PROPERLY AUTHORIZED REPRESENTATIVES OF EACH PARTY. BY USING THIS PRINTER, YOU AGREE TO ACCEPT THE TERMS AND CONDITIONS OF THIS AGREEMENT.

User's Manual

The Printronix P7000 Series PSA3™ Printers

PRINTRONIX® **PSA3**

This document contains proprietary information protected by copyright. No part of this document may be reproduced, copied, translated, or incorporated in any other material in any form or by any means, whether manual, graphic, electronic, mechanical, or otherwise, without the prior written consent of Printronix.

Printronix makes no representations or warranties of any kind regarding this material, including, but not limited to, implied warranties of merchantability and fitness for a particular purpose. Printronix shall not be held responsible for errors contained herein or any omissions from this material or for any damages, whether direct or indirect, incidental or consequential, in connection with the furnishing, distribution, performance, or use of this material. The information in this manual is subject to change without notice.

COPYRIGHT 1997, 2005 PRINTRONIX, INC.

Trademark Acknowledgements

IBM, AS/400, and Proprinter are registered trademarks, and Intelligent Printer Data Stream and IPDS are trademarks of International Business Machines Corporation.

Printronix, PGL, LinePrinter Plus, and IGP are registered trademarks, and P7005, P7010, P7015, P7205, P7210, P7215, P7220, and SureStak are trademarks of Printronix, Inc.

ANSI is a registered trademark of the American National Standards Institute, Inc.

Centronics is a registered trademark of Genicom Corporation.

CSA is a registered certification mark of the Canadian Standards Association.

Dataproducts is a registered trademark of Dataproducts Corporation.

EIA is a registered service mark of the Electronic Industries Association.

Epson is a registered trademark of Seiko Epson Corporation.

Ethernet is a trademark of Xerox Corporation.

IEEE is a registered service mark of the Institute of Electrical and Electronics Engineers, Inc.

QMS is a registered trademark, and Code V is a trademark of Quality Micro Systems, Inc.

TUV is a registered certification mark of TUV Rheinland of North America, Inc.

UL is a registered certification mark of Underwriters Laboratories, Inc.

ENERGY STAR is a registered trademark of the United States Environmental Protection Agency. As an ENERGY STAR® Partner, Printronix has determined that this product meets the ENERGY STAR guidelines for energy efficiency.



Trademark Acknowledgements



Table of Contents

1	Introduction	13
	Printer Overview	13
	The P7000 Series PSA3 Printer.....	13
	Integrated Print Management System.....	15
	Graphics Enhancements.....	17
	Taking Care Of Your Printer.....	17
	Conventions In This Manual	18
	Warnings And Special Information	18
	Related Documents	19
	Printronix Customer Support Center	20
2	Setting Up The Printer	21
	Before You Begin	21
	Power Requirements	21
	Select A Site	22
	Printer Dimensions	23
	Printer Component Locations	26
3	Operating The Printer	27
	Powering On The Printer	27
	Operating Modes	27
	The Control Panel.....	28
	Control Panel Keys	29
	Operational Procedures.....	34
	Reload Paper	34
	Unload Paper	45



Table of Contents

Integrated Print Management System	48
Lighter Or Darker Print	48
Changing Ribbons	49
Cancel A Print Job	52
4 The Configuration Menus.....	53
Configuration Overview	53
Changing Parameter Settings	54
Saving Parameter Settings	54
Default And Custom Configurations.....	55
Navigating The Menus	56
Changing Parameters Example	57
Auto Save Configuration	60
Saving Your New Configuration	61
Optimizing Print Quality.....	68
Optimizing Print Speed	69
Main Menu.....	70
QUICK SETUP	73
CONFIG. CONTROL	82
HOST INTERFACE	85
Auto Switching Submenu	86
IEEE 1284 Parallel (Bidirectional) Submenu.....	88
Centronics (Parallel) Submenu	91
Dataproducts (Standard) Submenu	94
Serial Submenu	98
E-Net Adapter Submenu	106
Ethernet Submenu	107
NETWORK SETUP MENU.....	108
ADAPTER ADDRESS.....	109
ADAPTER PARAMS	110
ETHERNET ADDRESS	113
ETHERNET PARAMS.....	115
WLAN ADDRESS	117
WLAN PARAMS.....	119

Table of Contents

WLAN KERBEROS	121
WLAN LEAP	123
ACTIVE (IGP) EMUL	125
IGP/PGL Emulation	126
Features	126
Configuring The Emulation With The Control Panel ...	128
IGP/PGL Submenu	129
IGP/PGL Submenu (with PCL-II)	131
IGP/PGL Submenu (with LG).....	132
IGP/VGL Emulation	146
Features	146
Configuring The Emulation With The Control Panel ...	147
IGP/VGL Submenu	148
IGP/VGL Submenu (with PCL-II)	150
IGP/VGL Submenu (with LG).....	152
EMULATION.....	166
Coax/Twinax (CTHI) Emulation	167
Standard.....	167
Simple Prot Conv	168
Coax Emulation.....	169
Twinax Params	180
3270 Params.....	187
5250 Params.....	196
SPC Coax Params	202
SPC Twx Params.....	206
LinePrinter Plus Emulation	209
LinePrinter Plus Emulation (with PCL-II)	212
P-Series Emulation	219
P-Series Emulation (with PCL-II)	220
P-Series Emulation (with LG).....	221
P-Series XQ Emulation	228
Serial Matrix Emulation	232



Table of Contents

Proprinter XL Emulation	236
Epson FX Emulation	241
ANSI Emulation	248
IPDS Emulation	257
PCL - II Emulation	263
LG Emulation.....	269
PRINTER CONTROL	276
ADVANCED USER.....	281
DIAGNOSTICS.....	289
5 Interfaces	293
Overview.....	293
Dataproducts Parallel Interface	294
Dataproducts Parallel Interface Signals	295
Centronics Parallel Interface	296
Centronics Parallel Interface Signals	297
IEEE 1284 Parallel Interface	298
Compatibility Mode.....	298
Nibble Mode	298
Byte Mode	298
Signals	299
Terminating Resistor Configurations.....	302
RS-232 And RS-422 Serial Interfaces.....	304
RS-232	305
RS-422	306
6 Reprogramming The Security Key	307
Reprogramming The Security Key	307
How To Program The Security Key.....	307

Table of Contents

7	Troubleshooting	311
	Cleaning Requirements	311
	Exterior Cleaning	311
	Interior Cleaning	312
	Diagnosing Problems	314
	Bar Code Verification	314
	Printing A Hex Dump	315
	Fault Messages	316
A	Printer Specifications	345
	Ribbon Specifications	345
	Paper Specifications	346
	Printer Weight And Dimensions	348
	Environmental Characteristics	348
	Electrical Characteristics	350
	Interfaces	351
	Printing Rates	351
B	ASCII Character Set	353
C	Communication Notices	355
	Notices	355
	Energy Star	358
	Product Recycling and Disposal	359
	Communication Statements	360
	Lithium Battery Warning	365
	Software License Agreement	366



Table of Contents

1

Introduction

Printer Overview

This chapter provides a general overview of your printer and the conventions used within this manual.

The P7000 Series PSA3 Printer

The Printronix® P7000 PSA3™ Printer consists of 500, 1000, 1500, lines per minute (lpm) cabinet and pedestal models and a 2000 lpm cabinet model. All printer models are packaged in various configurations that offer software versatility and the latest refinements in printing technology. The print mechanisms are housed in sound-insulated cabinets which make the printer among the quietest line matrix printers in the world. Additionally, your printer has a flexible architecture that allows you to add new features and emulations as they become available.

LinePrinter Plus® is the standard emulation. LinePrinter Plus includes the Epson® FX-1050, Printronix P-Series, P-Series XQ, Serial Matrix and Proprinter® III XL emulations. Coax/Twinax, IPDS™, ANSI®, LG, PCL2, IGP®/PGL®, and IGP/VGL graphics enhancement emulations are available as optional upgrades. No matter what emulation is installed, your printer is easy to use. The message display and lights on the control panel communicate with you directly and clearly. You can select every function on your printer at the control panel, or you can send commands from the host computer.

Chapter 1 Printer Overview

The printer model numbers indicate printing speed and physical configuration. Model numbers beginning with P70 indicate pedestal models. Model numbers beginning with P72 indicate cabinet models. The final two digits in the model number refer to the printer's maximum speed in lines per minute (lpm): 05 for 500 lpm, 10 for 1000 lpm, 15 for 1500 lpm, and 20 for 2000 lpm.

Refer to the following table for a complete listing of model numbers and options.

Table 1. The Printronix P7000 Printers

Model Number	Print Speed	Model Type	Power Stacker
P7005	500 lpm	Pedestal	
P7010	1000 lpm	Pedestal	
P7015	1500 lpm	Pedestal	
P7205	500 lpm	Cabinet	N/A
P7210	1000 lpm	Cabinet	Option
P7215	1500 lpm	Cabinet	Option
P7220	2000 lpm	Cabinet	Option

Integrated Print Management System

The P7000 has a new feature that automatically monitors and communicates ribbon life. Using a specially barcoded spool, the printer can automatically detect when a new or used ribbon is loaded, and all ribbon properties. With a sophisticated algorithm, the system monitors all jobs printed and automatically updates the remaining ribbon life on the front panel display. This allows the system administrator to have precise control over print quality and consumable costs. The accurate presentation of available ribbon life allows for efficient planning of print jobs. For example, you can install a new ribbon before printing large print jobs.

When the ribbon life gets near the end point, the printer displays a ribbon low message and flashes the indicator light. Printing will continue without interruption. Once the ribbon reaches 0% remaining, the alarm sounds, the indicator light flashes, the display updates, and printing pauses. If a new ribbon is loaded, the system automatically detects the change, clears the condition, and restarts the life at 100%. If it is not convenient to change the ribbon immediately, cycle the printer on and offline and it will resume printing for a few minutes. This should be enough to complete the job. If not, repeat the same procedure indefinitely to extend printing on the same ribbon.

Output Darkness

By default the system is configured to meet most user requirements. However, some applications require that the output remains darker than the nominal set point while some applications are less critical and could tolerate a lighter final image. The system can easily adjust to this variability. A setting under the Printer Control menu is available that allows the user to adjust the final output. The range is as follows:

Normal (Default)
Darker +1 through +6
Lighter -1 through -10

The ribbon life indicator always cycles between 100% and 0%, but if a darker setting is selected, zero will be reached more quickly.

If a lighter setting is selected, the system will extend the amount of printing it takes to reach zero.

Ribbon Flipping

In some cases, the application's print pattern is narrow enough where only half of the ribbon is used when printing. In these cases, you can flip the ribbon and use the other half. The Integrated Print Management System detects the flip and resets the ribbon life to 100%.

NOTE: It is the user's responsibility to ensure the print pattern is sufficiently narrow to support flipping. If not, the ribbon life may falsely indicate 100% for the flipped ribbon.

Loading a Used Ribbon

You can take ribbons off the printer and reload it at a later time. The ribbon life gauge automatically updates to reflect the correct remaining capacity.

NOTE: The ribbon must be reloaded back onto the same printer, and in the same orientation as it was removed. If the used ribbon is loaded onto a different printer, or if it is flipped over, it will incorrectly indicate the ribbon as new.

Ribbon Log

The Integrated Printer Management System tracks all used ribbons. This data allows you to monitor how many ribbons and ribbon types have been used on the printer. This data is contained in the ribbon log. To print the ribbon log, see page 289.

Consumable Monitoring With PrintNet Enterprise

The Integrated Print Management System works with PrintNet Enterprise (PNE). PNE allows a system administrator to remotely view the current consumable status of all printers. PNE can be configured to deliver alerts on all consumable warnings. When a ribbon reaches the low state, PNE notifies the system administrator remotely via an automated e-mail alert of the low condition. This allows corrective action to be taken before the ribbon reaches its end of life. If the ribbon is not changed, an alert will again be initiated once the ribbon reaches the 0% end point. Refer to your PrintNet Enterprise Remote Management Software manual for details.

Graphics Enhancements

The IGP/PGL and IGP/VGL emulations allow you to create and store forms, generate logos, bar codes, expanded characters, and create other graphics. Alphanumeric and bar code data are added as the form is printed.

These emulations are available as factory-installed or field-installed options. For more information, contact your authorized service representative.

Taking Care Of Your Printer

Your printer will produce high print quality jobs if it is well taken care of. Periodic cleaning, handling the printer properly, and using the correct printer supplies such as ribbon and paper ensures optimum performance. Chapter 7 explains how to clean the printer, and printer supplies are listed in Appendix A.

Whenever it is necessary to service the printer, remember these important maintenance concepts:

- Incorrect closure of the platen lever can lead to smearing, degraded print quality, paper jams, and damage to the platen and shuttle assembly. Never close the platen lever too tightly.

Conventions In This Manual

All uppercase print indicates control panel keys.

Example: Press the CLEAR key, then press the ON LINE key.

Quotation marks (“ ”) indicate messages on the Liquid Crystal Display (LCD).

Example: Press the ON LINE key. “OFFLINE” appears on the LCD.

The + (plus) symbol represents key combinations.

Example: “Press ▲ + ▼” means press the ▲ (UP) key and the ▼ (DOWN) key at the same time.

Warnings And Special Information

Read and comply with all information highlighted under special headings:

WARNING A warning notice calls attention to a condition that could harm you.

CAUTION A caution notice calls attention to a condition that could damage the printer.

IMPORTANT Information vital to proper operation of the printer.

NOTE: A note gives you helpful tips about printer operation and maintenance.

Related Documents

- *Maintenance Manual* — Explains how to maintain and repair the line matrix printer at the field service level of maintenance.
- *Coax/Twinax Programmer's Reference Manual* — Covers the host control codes and character sets for the Coax and Twinax emulations.
- *Coax/Twinax Programmer's Reference Manual for the Simple Protocol Converter Option* — Covers the host control codes and character sets for the Coax and Twinax Simple Protocol Converter emulations.
- *LinePrinter Plus Programmer's Reference Manual* — Covers the host control codes for the LinePrinter Plus emulation.
- *IGP/PGL Programmer's Reference Manual* — Provides information used with the optional IGP Printronix emulation enhancement feature.
- *IGP/VGL Programmer's Reference Manual* — Provides information used with the optional Code V™ emulation enhancement feature.
- *ANSI Programmer's Reference Manual* — Provides host control codes and character sets for the ANSI emulation.
- *IPDS Twinax Emulation Programmer's Reference Manual* — Provides an overview of Intelligent Printer Data Stream™ (IPDS) features, commands, and diagnostics.
- *Character Sets Reference Manual* — Information about and examples of the character sets available in line matrix printers.
- *Network Interface Card User's Manual* — Information about network protocols, configuration, and operation.

Printronix Customer Support Center

The Printronix Customer Support Center offers technical support with:

- Installation
- Configuration and setup
- Operation and supplies loading
- Specifications of the proper print media and ribbon
- Answers to post-sale service support questions

Call the Printronix Customer Support Center at:

1-714-368-2686 in the Americas

31-24-6489489 in Europe, Middle East, and Africa

65-65484114 in Asia Pacific

or visit the Printronix web page at www.printronix.com

<http://www.printronix.com/public/servicesupport/default.aspx>

2

Setting Up The Printer

Before You Begin

Read this chapter carefully before installing and operating the printer. The printer is easy to install. However, for your safety and to protect valuable equipment, perform all the procedures in this chapter in the order presented.

Power Requirements

The printer must be connected to a power outlet that supplies AC 100V to 240V +/- 10% at 50 to 60 Hz. The printer automatically senses and adjusts itself to conform to the correct voltage range.

Primary circuit protection is provided by the power switch, which is also a circuit breaker. Consult an electrician if printer operation affects local electrical lines.

IMPORTANT

Printer power should be supplied from a separate AC circuit protected at 10 amperes for 100 - 120 volts or 5 amperes for 200 - 240 volts at 50 or 60 Hertz.

Select A Site

Select a printer site that meets all of the following requirements:

- Permits complete opening of the printer cover and doors.
- For cabinet models, allows at least three feet of clearance behind the printer. (This permits air to circulate freely around the printer and provides access to the paper stacking area.)
- Has a standard power outlet that supplies 88-135 Volts AC or 178-270 Volts AC power, at 47 to 63 Hz.
- Is relatively dust-free.
- Has a temperature range of 10° C to 40° C (50° F to 104° F) and a relative humidity from 15% to 90% non-condensing.
- Is located within the maximum allowable cable length to the host computer. This distance depends on the type of interface you plan to use, as shown in Table 2.

Table 2. Maximum Interface Connection Cable Length

Interface Type	Maximum Cable Length
Centronics Parallel	5 meters (15 feet)
Dataproducts Parallel	12 meters (40 feet)
IEEE 1284 Parallel	10 meters (32 feet)
Serial RS-232	15 meters (50 feet)
Serial RS-422	1220 meters (4000 feet)
Coax	1500 meters (4920 feet)
Twinax	1500 meters (4920 feet)
Twinax (shielded cable)	1500 meters (4920 feet)
Twisted Pair / Type 3	300 meters (985 feet)
Ethernet 10/100Base-T	100 meters (328 feet)

Printer Dimensions

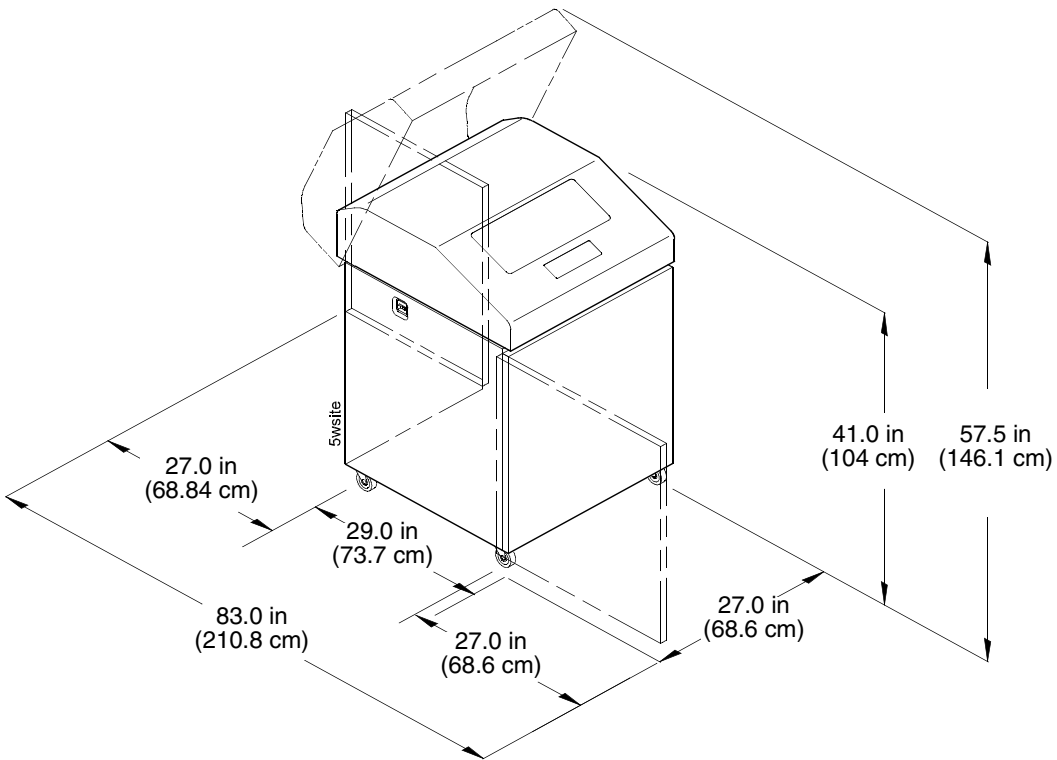

Figure 1. Printer Dimensions - Cabinet Model

Chapter 2 Printer Dimensions

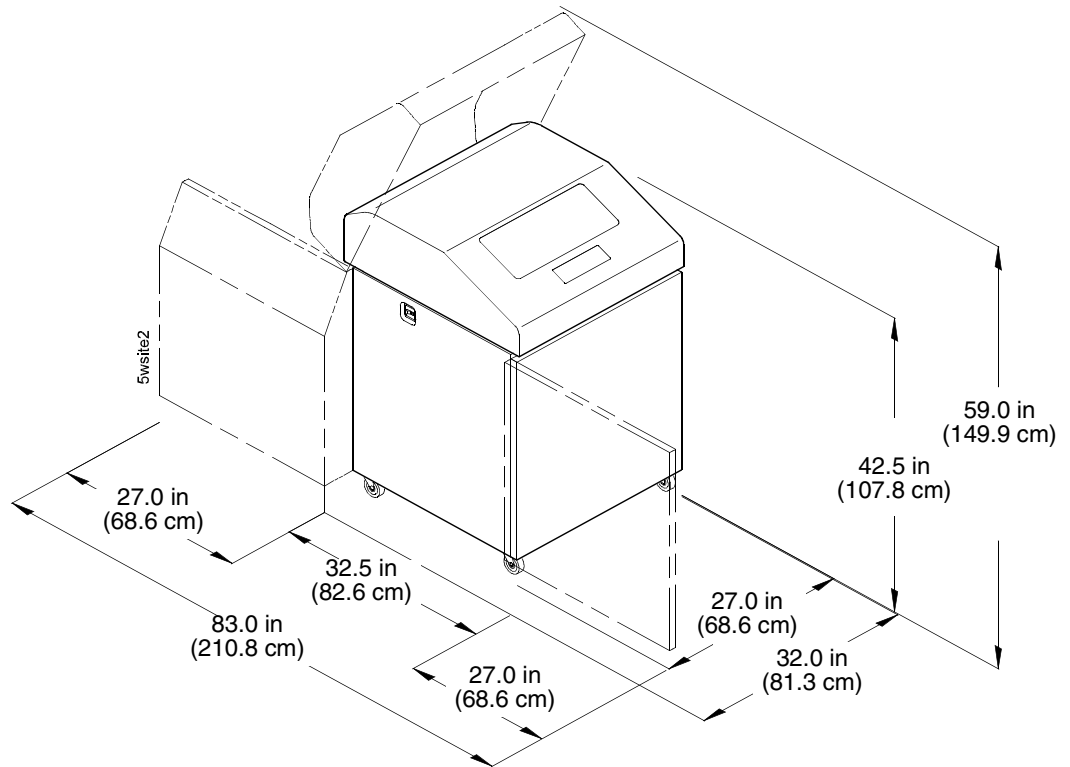

Figure 2. Printer Dimensions - Cabinet Model with Paper Stacker

Printer Dimensions

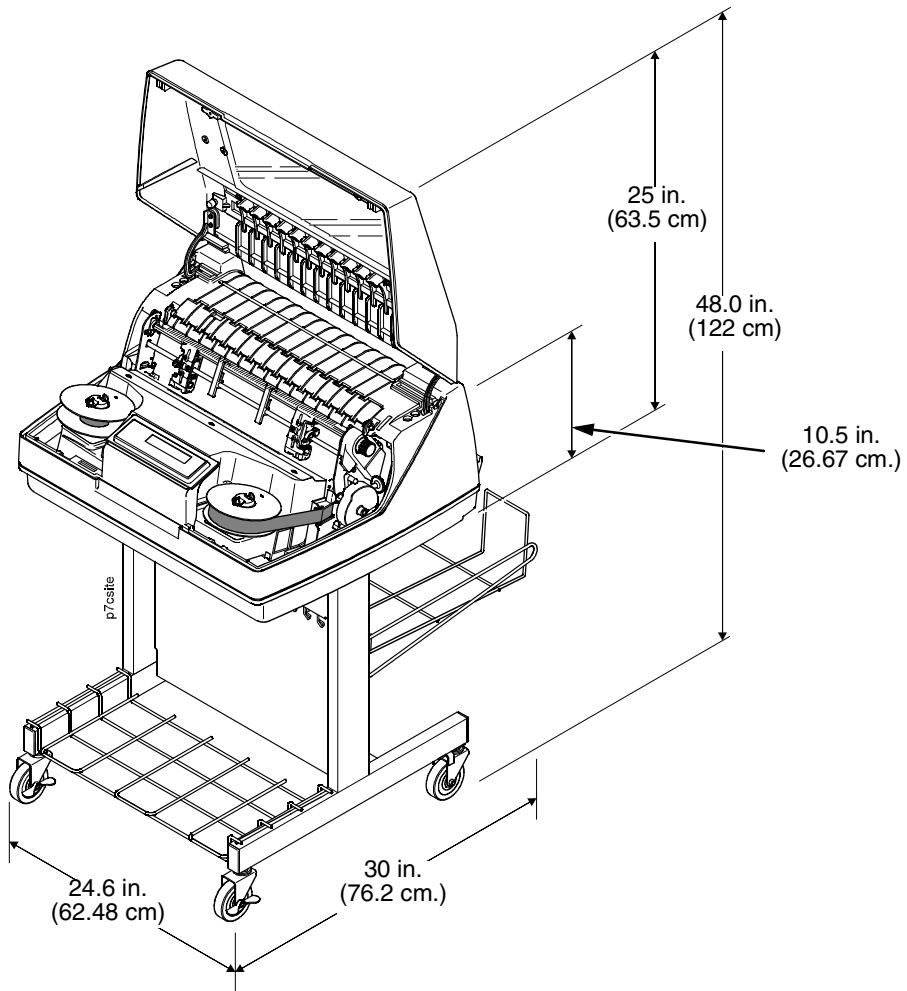

Figure 3. Printer Dimensions - Pedestal Model

Printer Component Locations

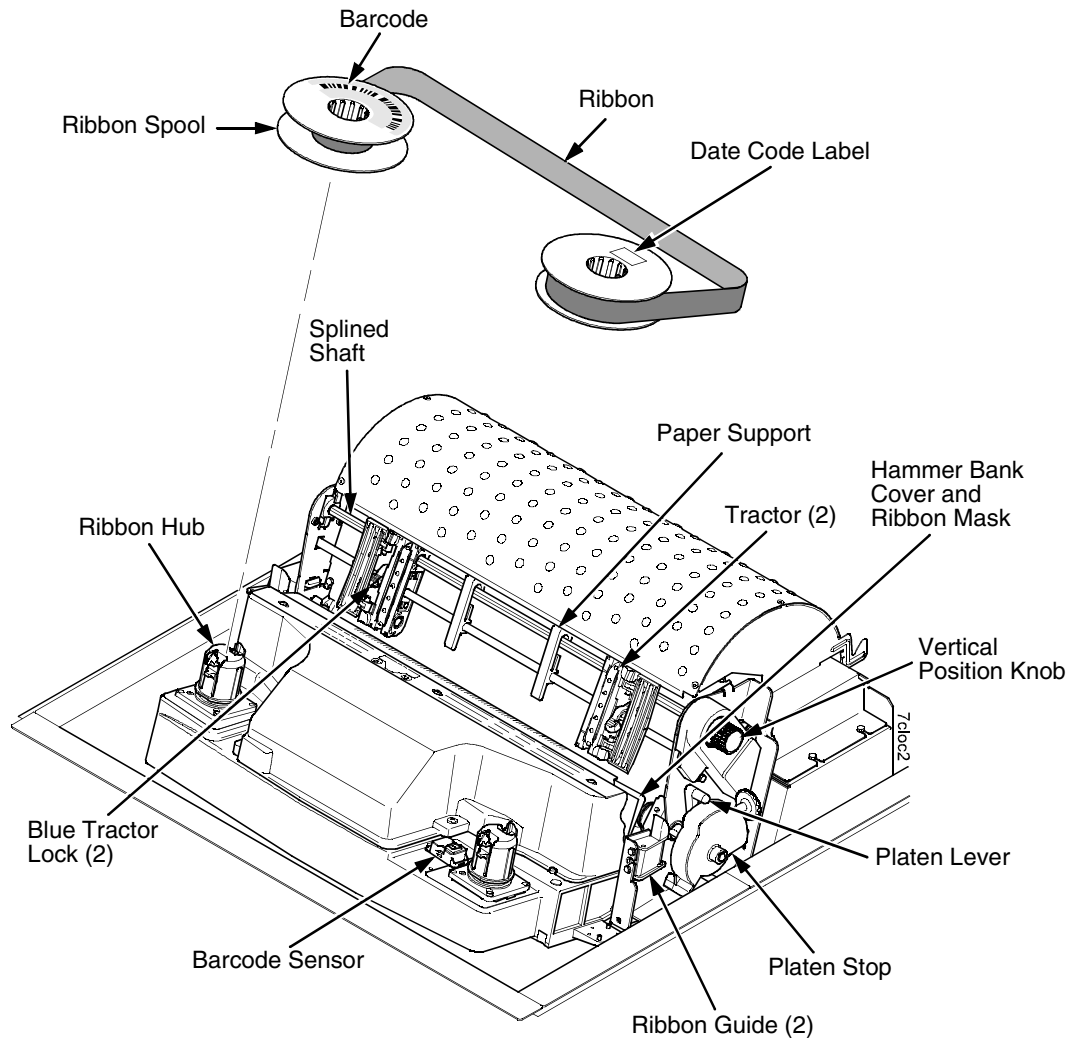

Figure 4. Printer Component Locations

3

Operating The Printer

Powering On The Printer

When you power on the printer, it executes a self-test. The default power-up state is online. When the self-test completes and the software has initialized successfully, the status indicator light turns on, indicating the printer is online. The default value of the type of emulation you have installed appears upper right corner of the display. The ribbon life remaining is shown on the second line.

If there is a fault during the self-test, the status indicator flashes and a specific fault message appears on the display (such as “LOAD PAPER”). The alarm also sounds if it is configured to do so. See “LCD Message Troubleshooting Table” on page 317 for information on fault messages and solutions.

Operating Modes

Online. In online mode, the printer can receive and print data sent from the host. Pressing the ON LINE key toggles the printer from offline to online mode. The status indicator is lit in online mode.

Offline. In offline mode, you can perform operator functions, such as loading paper and setting top-of-form. You can also move within the printer configuration menus. Pressing the ON LINE key toggles the printer from online to offline mode. The status indicator is off in offline mode.

Fault. In fault mode, a condition exists which must be cleared before printing can continue. The status indicator flashes, the alarm

Chapter 3 The Control Panel

beeps (if configured to sound), and a descriptive fault message displays.

The current operating mode can be selected via control panel keys or can result from routine operations such as powering on the printer.

The Control Panel

Figure 5 shows the keys, displays, and indicators as they appear on the control panel. The following section provides the descriptions, and functions of the control panel keys.

Key combinations are indicated with the plus (+) sign. For example, “Press \triangle + ∇ ” means to press the \triangle key and the ∇ key at the same time.

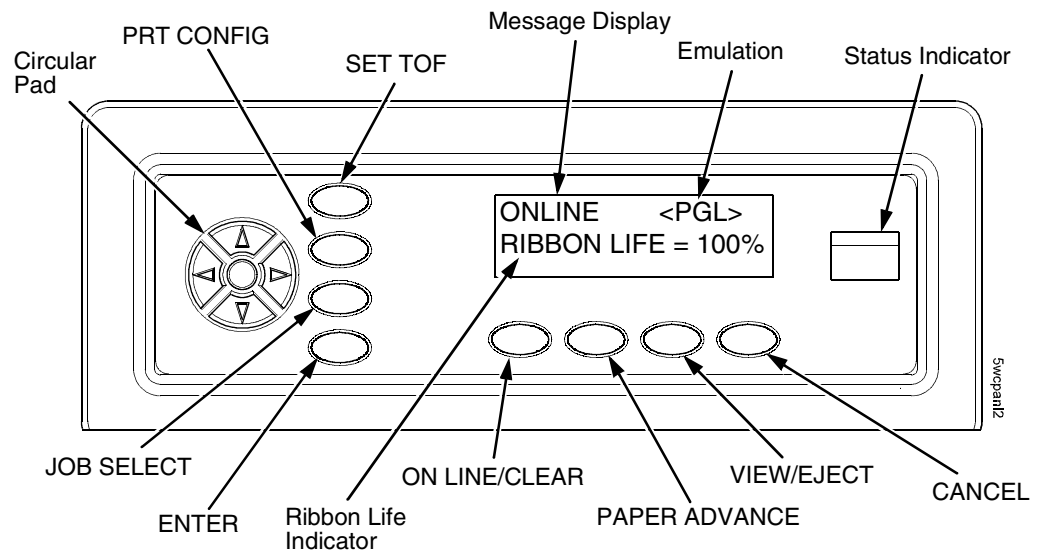

Figure 5. Control Panel

Control Panel Keys

ON LINE / CLEAR

Toggles the printer between online and offline modes. If a fault condition exists, pressing this key will clear the fault message and return the printer from fault mode to offline mode.

NOTE: If the fault condition is not corrected *before* pressing this key, the fault message will reappear when attempting to place the printer online.

PAPER ADVANCE

Performs advance to top-of-form, as defined by the current active form length. The key works both online and offline.

- If online with data in the printer buffer, the data will print and then the paper will move to the next top-of-form.
- In the fault state, PAPER ADVANCE will advance the paper. The first press moves to the top of the next available form. All subsequent presses advances one forms length as defined by the current active forms length.

VIEW / EJECT

When the printer is online or offline, pressing this key executes the view or eject function, depending on whether the printer is a cabinet or a pedestal (or zero tear pedestal).

If online with data in the printer buffer, the data prints and the key functions as described below.

If in a fault state, this key will be ignored.

- **View Function** — for cabinet models, pressing the VIEW/EJECT key moves the last data printed to the tractor area for viewing. While in the view state, the message "Printer in View" displays, pressing the UP or DOWN arrow keys moves the paper up or down in 1/72 inch increments. This is done to align the image within a pre-printed form, for example. Refer to the UP and DOWN key functions for additional details on the

Chapter 3 The Control Panel

microstep feature. Pressing VIEW/EJECT a second time moves the paper back to the adjusted print position.

Eject Function — for pedestal models, when the VIEW/EJECT key is pressed, the bottom of the last printed form will move to the tear bar position. The message "READY TO TEAR/EJECT To Return" displays. While in this position, pressing the UP or DOWN arrow keys moves the paper up or down in 1/72 inch increments. Refer to the Up and Down key functions for additional details on the microstep feature. When the VIEW/EJECT key is pressed a second time, the printer will move the paper to enable printing on the next available form.

CANCEL

In offline mode, this key cancels all data in the print buffer, if enabled in "ADVANCED USER" on page 281. The print buffer is cleared without printing any of the data and the current paper position is set as the top-of-form. If this function is disabled, the CANCEL key will be ignored.

NOTE: Use of this key will cause loss of data.

SET TOF

Sets the top-of-form on the printer. This key is active only when the printer is offline and will not operate if the printer is in a fault condition. The paper moves down to the print position and aligns to the top-of-form. Refer to the *Quick Setup Guide* for complete instructions on how to set the top-of-form.

NOTE: If there is any data in the buffer, the paper will move to the last print position.

PRT CONFIG

In offline mode, PRT CONFIG prints the current short configuration. This key requires a confirmation with the ENTER key; pressing any other key will exit from this function. See "The Configuration Menus" on page 53 for an explanation of configuration menus.

JOB SELECT

In offline mode, this key allows you to change the active configuration if multiple configurations have been saved or the typeface of the printer.

ENTER

When navigating the configuration menus, ENTER selects the currently displayed option value as the active value. An asterisk (*) appears next to the active value on the display. ENTER is also used for starting and stopping printer tests and generating a configuration printout.

NOTE: The ENTER key must be unlocked in order to function. See UP + DOWN, below. The ENTER key lock and unlock function can be configured to be a key combination other than ▲ + ▼ (see page 288).

UP or DOWN (▲ or ▼)

Moves up or down between levels in the configuration menus and makes vertical forms adjustment. After pressing VIEW, press ▲ or ▼ to adjust the paper up or down in 1/72 inch increments for fine vertical forms alignment. When the printer is in offline mode, press ▲ or ▼ to move through levels in the configuration menus.

UP + DOWN (▲ + ▼)

Locks and unlocks the ENTER key.

NOTE: The ENTER key lock and unlock function can be configured to be a key combination other than ▲ + ▼ (see page 288).

PREV or NEXT (◀ or ▶)

Moves between the options on the current level of configuration menu. In the configuration menu, press ◀ to scroll backward or press ▶ to scroll forward through the menu selections on the same level.

PREV + NEXT (◀ + ▶)

When both keys are pressed simultaneously, the printer will reset to the power-up configuration and reset its internal state.

▲ + ON LINE (IPDS Emulation only)

In offline mode, press ▲ + ON LINE. If there is data in the printer buffer, the printer will be placed in online mode, print one page, and return to the offline mode. This action can be repeated until the end of a print job. Only one page prints each time you press ▲ + ON LINE. If there is no data in the printer buffer, the printer is placed in online mode.

In the fault state, ▲ + ON LINE does not work.

▲ + PAPER ADVANCE (IPDS Emulation only)

In offline mode, press ▲ + PAPER ADVANCE. The printer will perform a reverse linefeed. If you hold down the ▲ + PAPER ADVANCE keys for longer than 1/2 second, the printer moves to the previous top-of-form position. If there is data in the printer buffer, the data does not print.

In the fault state, ▲ + PAPER ADVANCE does not work.

▲ + VIEW (IPDS Emulation only)

In offline mode, press ▲ + VIEW. If there is data in the IPDS printer buffer, the printer will be placed in online mode, print one line, and return to offline mode. This action can be repeated until the end of the job. This function prints only one line of text. If the data is not text, only 1/6 inch prints. If there is no data in the printer buffer, the printer is placed in online mode for one second and then returns to offline mode.

In the fault state, ▲ + VIEW does not work.

Ribbon Life Indicator

Indicates life remaining of the currently installed ribbon. The default settings for this feature should match the requirements for most applications; no special user setup is needed. If your particular application requires darker printing or can tolerate lighter printing, the ribbon end point can be adjusted as appropriate. Please refer "Ribbon End Point" on page 80.

Operational Procedures

This section contains routine printer operating procedures on how to:

- reload paper
- unload paper
- cancel a print job.

Reload Paper

Do this procedure when “LOAD PAPER” displays. (This message occurs when the last sheet of paper passes through the paper slot.) This procedure reloads paper without removing the last sheet of the old paper supply, while retaining the current top-of-form setting.

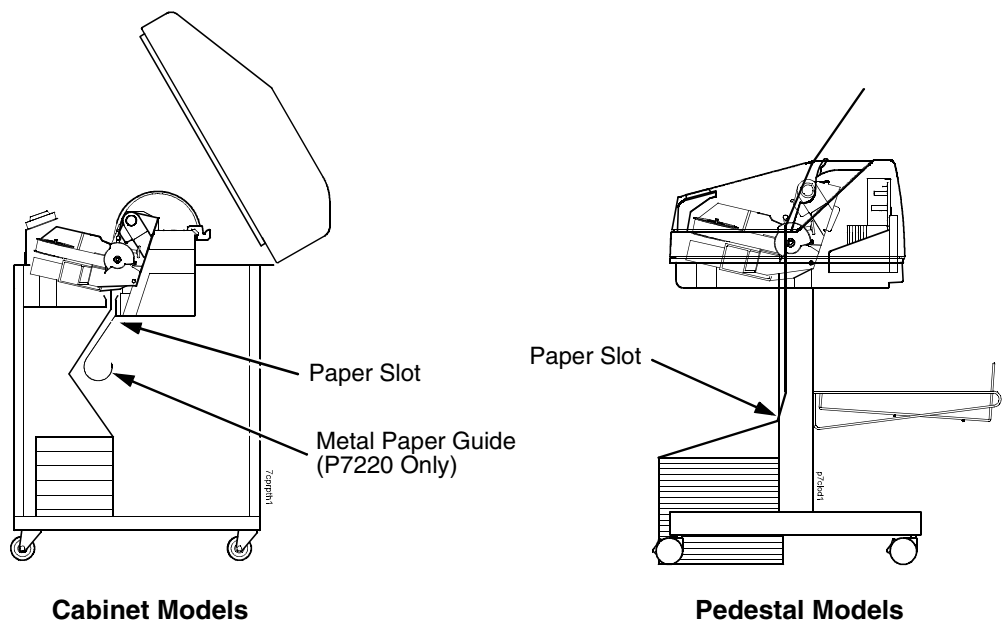

Figure 6. Paper Slot Location

Reload Paper

1. Raise the printer cover. Raise the platen lever as far as it will go. (See Figure 4 on page 26 for the location of the lever.)
2. Press ON LINE/CLEAR to turn off the alarm. Do not open the tractor doors or remove the existing paper.
3. For cabinet models, open the front door. Align the paper supply with the label on the floor. Ensure the paper pulls freely from the box.
4. Feed the paper up through the paper slot (see Figure 6). It may be easier to feed one corner of the new paper up through the slot first. When this corner can be grasped from the top, rotate the paper back to the normal position.

NOTE: If you are using thick, multi-part forms and are unable to load the new paper over the existing paper, go to step 16.

5. Hold the paper to prevent it from slipping down and through the paper slot.

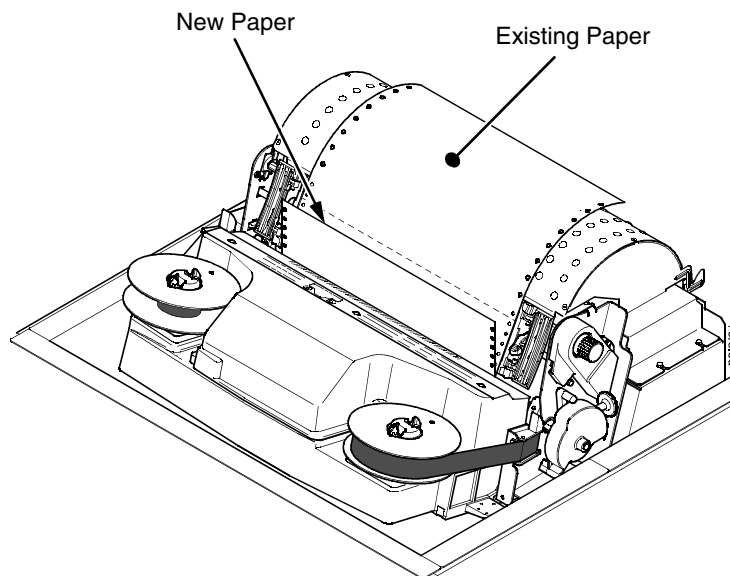

Figure 7. Loading New Paper into the Printer

6. Pull the new paper above and behind the ribbon mask, but in front of the existing paper. See Figure 4 on page 26 for the ribbon mask location. If necessary, gently press the existing paper back.
7. Align the top edge of the new paper with the top perforation of the existing paper.
8. Load the new paper over the existing paper. Open and load the tractors one at a time to prevent the paper from slipping.

NOTE: Make sure that the top edge of the new paper lines up with the top horizontal perforation of the last page.

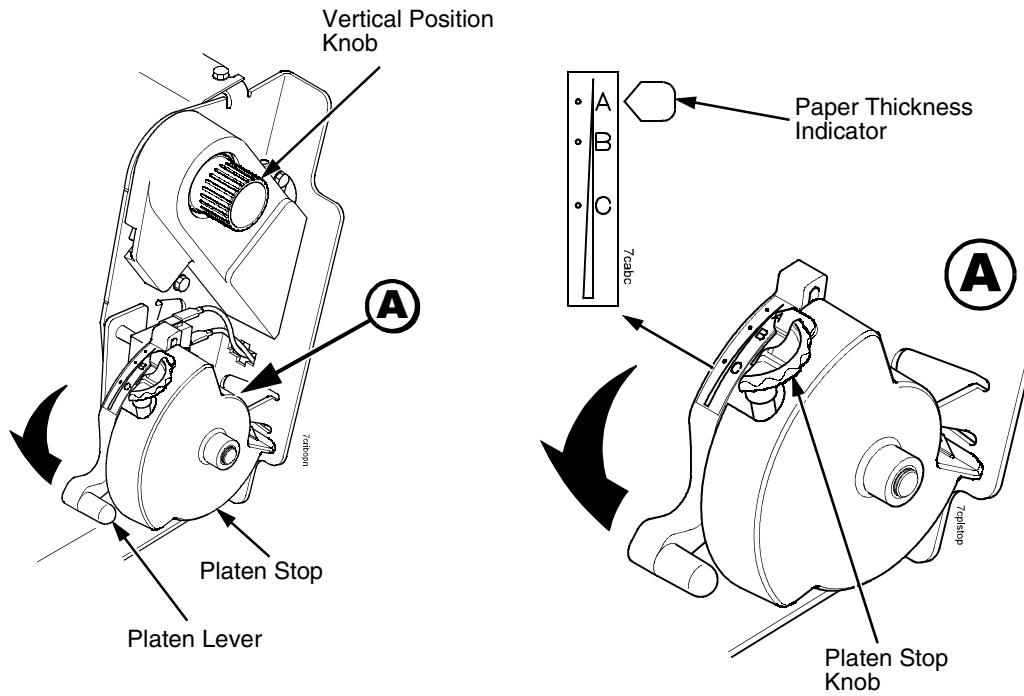

Figure 8. Setting the Platen Lever

9. Turn the vertical position knob to feed the paper up into the paper guide assembly, removing the last printed sheet.
10. Turn the platen stop knob clockwise or counterclockwise to match the paper thickness. (The A-B-C scale corresponds approximately to 1-, 3-, and 6-part paper thickness).

NOTE: If you are using the same thickness of paper, there is no need to readjust.

11. Lower the platen lever until it stops.
12. Press ON LINE/CLEAR to remove the “LOAD PAPER” fault message from the display.

Chapter 3 Operational Procedures

13. Press PAPER ADVANCE several times to make sure the paper feeds properly beyond the tractors and over the lower paper guide. Feed sufficient paper to ensure the paper stacks correctly.
14. Close the printer top cover. Close the cabinet front door.
15. Press ON LINE/CLEAR to place the printer in online mode and resume printing.

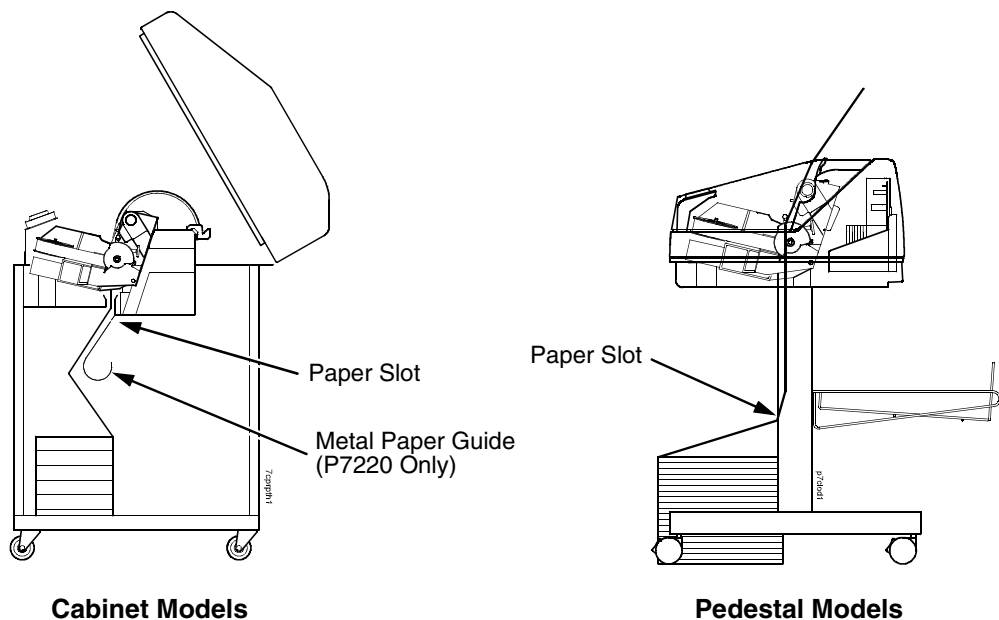

Figure 9. Paper Slots on the Printers

NOTE: Perform steps 16 to 33 only if you are unable to load the new paper over the existing paper.

16. Open both tractor doors.
17. Remove the old paper from the tractors. Allow the paper to fall into the paper supply area.
18. Feed the new paper up through the paper slot. Hold the paper to prevent it from slipping down through the paper slot.

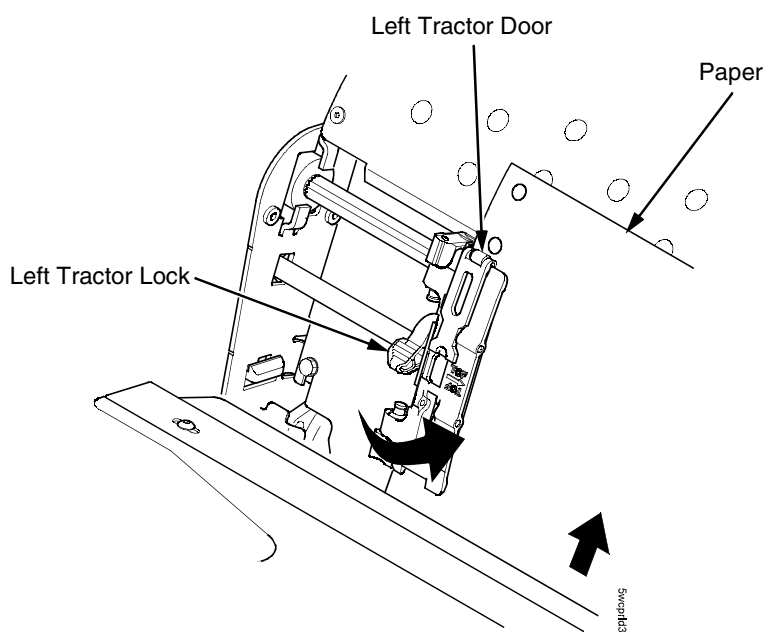

Figure 10. Loading Paper on the Left Tractor

19. Pull the paper above and behind the ribbon mask. See Figure 4 on page 26 for the ribbon mask location.
20. Load the paper on the left tractor.
21. Close the tractor door.

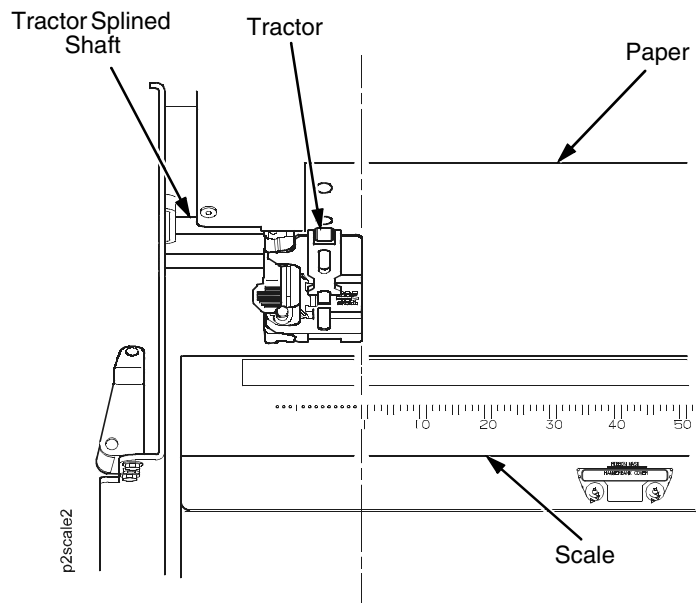

Figure 11. Positioning the Left Tractor to Avoid Damage

CAUTION To avoid damage to the printer caused by printing on the platen, always position the left tractor unit directly to the left of the “1” mark on the paper scale.

22. Normally, you should not need to adjust the position of the left tractor. If adjustment is necessary, unlock the left tractor. Slide the tractor until it is directly to the left of the number “1” on the paper scale and lock it. (You can also use the paper scale to count columns.)

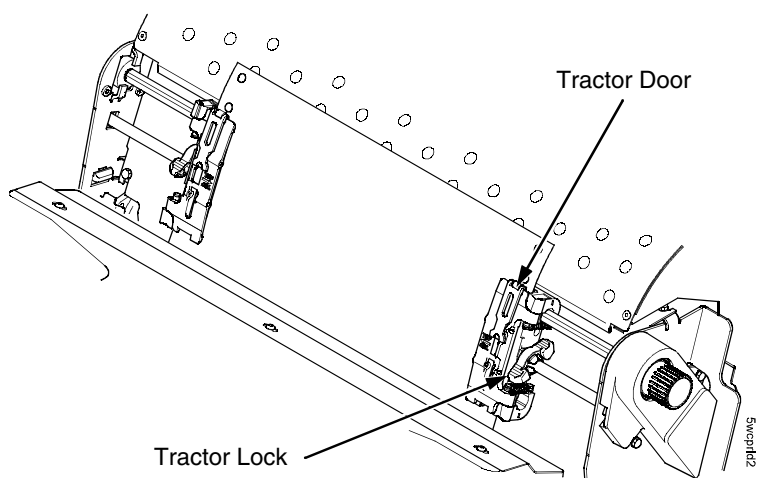

Figure 12. Loading Paper onto the Sprockets

23. Unlock the right tractor.
24. Load the paper onto the sprockets and close the tractor door. If necessary, slide the right tractor to remove paper slack or to adjust for various paper widths. Then, lock the tractor.

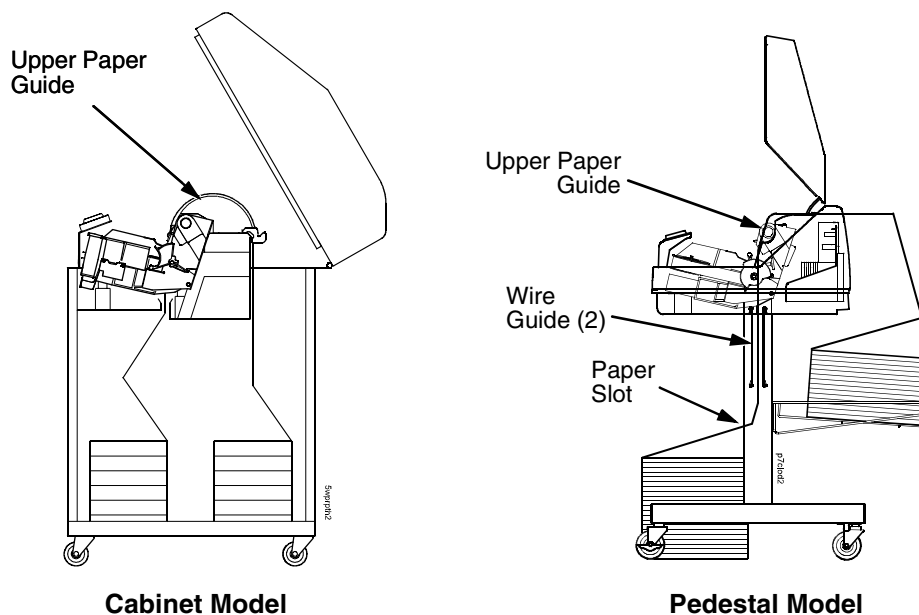

Figure 13. Using the Paper Guide to Orient the Paper

25. **Pedestal models:**

Using the vertical position knob to move the paper up, guide the paper over the upper paper guide and through the slot to the rear of the top cover. For pedestal models with the Quick Access Cover, refer to the *Quick Setup Guide* for paper exiting options.

26. Press PAPER ADVANCE several times to make sure the paper feeds properly beyond the tractors and over the lower paper guide. Feed sufficient paper to ensure the paper stacks correctly.

27. **Cabinet models:**

Open the cabinet rear door. Make sure the paper is aligned with the label in the output area (inside the cabinet). Close the front and rear doors.

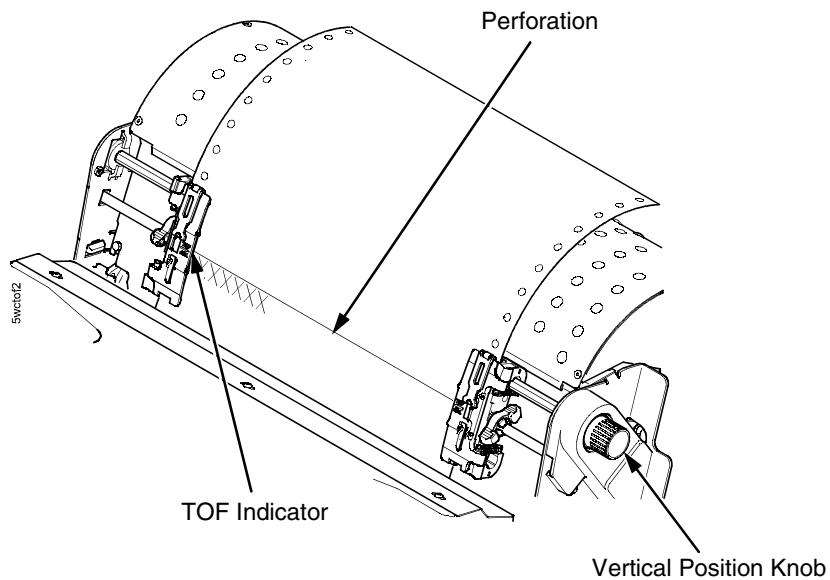

Figure 14. Aligning the Perforation with the TOF Indicator

28. Align the top of the first print line with the TOF indicator on the tractor by rotating the vertical position knob. For best print quality, it is recommended that the top-of-form be set at least one print line or more below the perforation.

NOTE: For exact positioning, press the VIEW/EJECT key to move the last data printed to the tractor area for viewing. While in View mode "Printer in View" displays. Press the Up or Down Arrow keys to move the paper vertically in small increments. Pressing the VIEW/EJECT key a second time moves the paper back to the adjusted print position. The key works both online and offline provided that the printer is in View mode. (This procedure is applicable for both the cabinet and pedestal models.)

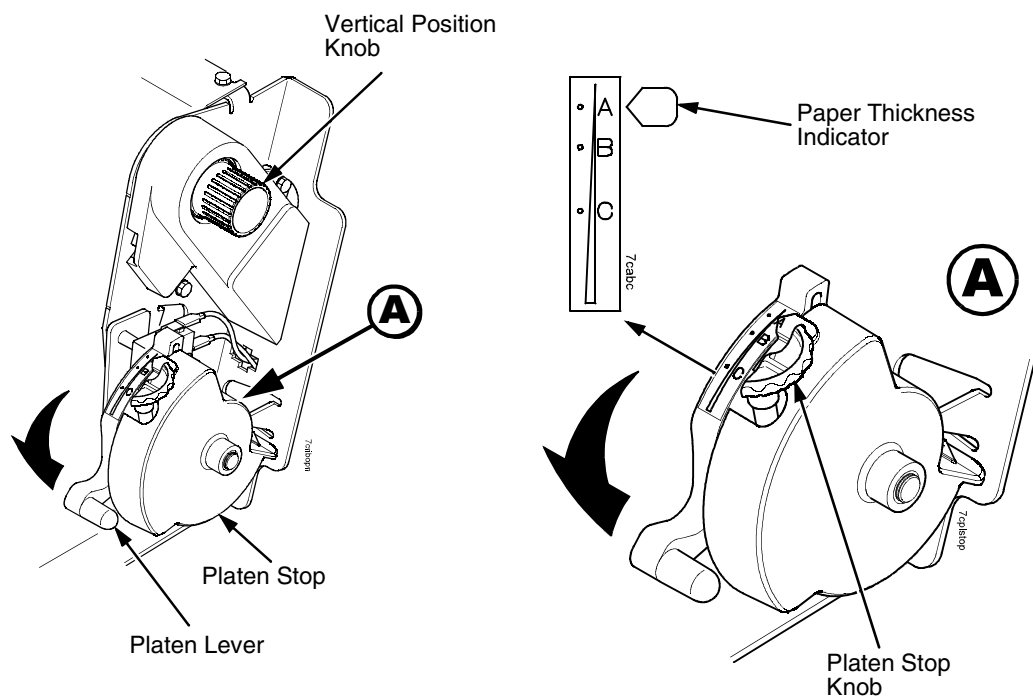

Figure 15. Adjusting the Platen Lever

29. Turn the Auto Platen Stop Knob clockwise or counterclockwise to match the paper thickness. (The A-B-C scale corresponds approximately to 1-, 3-, and 6-part paper thickness. Adjust until you have the desired print quality).

NOTE: The platen stop allows you to set an optimum and consistent thickness that is not affected when opening and closing the platen lever.

30. Lower the platen lever until it stops.

31. Press ON LINE/CLEAR to clear any fault messages (such as "LOAD PAPER") from the LCD.

32. Press SET TOF. The top-of-form you have set moves down to the print position. If there is data in the buffer, the paper moves forward to the last print position on the next page.

33. Press ON LINE/CLEAR and close the printer cover.

Unload Paper

1. Press ON LINE/CLEAR to place the printer in offline mode and open the printer cover.
2. For cabinet models, open the cabinet rear door. For models with the power stacker installed, press the STACKER UP key on the rear control panel.

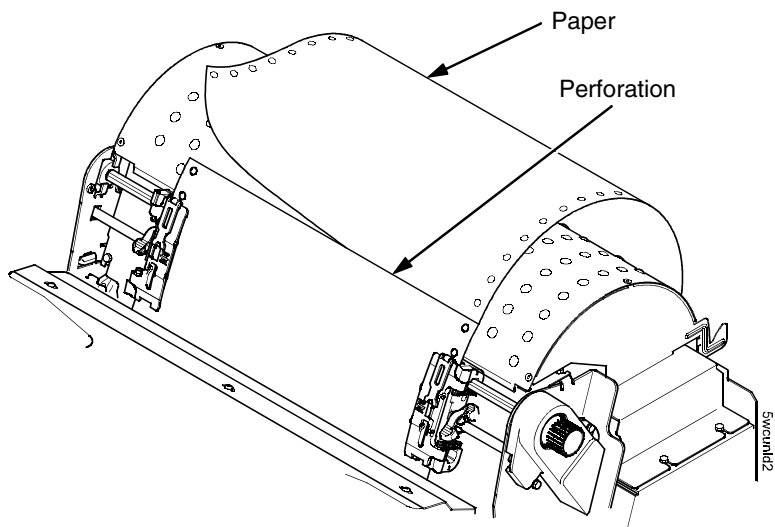

Figure 16. Unloading the Paper from the Printer

3. Tear off the paper at the perforation.
4. Allow the paper to fall to the back of the printer and into the paper stacking area.
5. For pedestal models, remove the stacked paper from the paper tray.

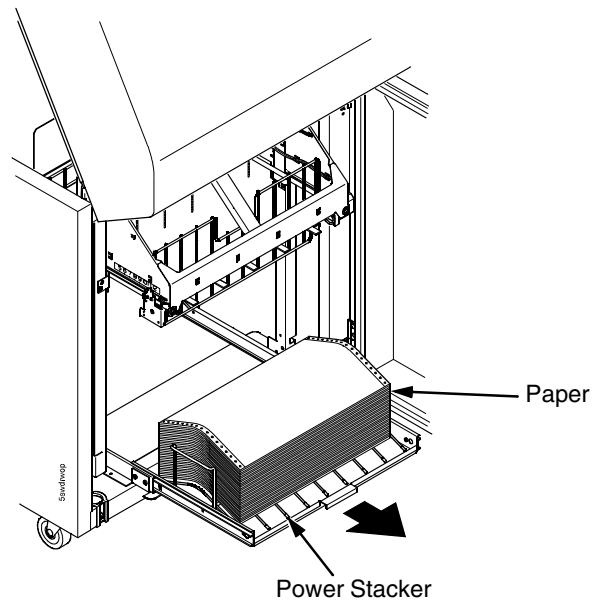

Figure 17. Removing Stacked Paper from the Printer

6. For cabinet models, remove the stacked paper from the rear cabinet floor. For cabinet models with the power stacker installed, remove the paper from the wire paper tent and press the STACKER DOWN key to lower the stacker mechanism.
7. Close the cabinet rear door.

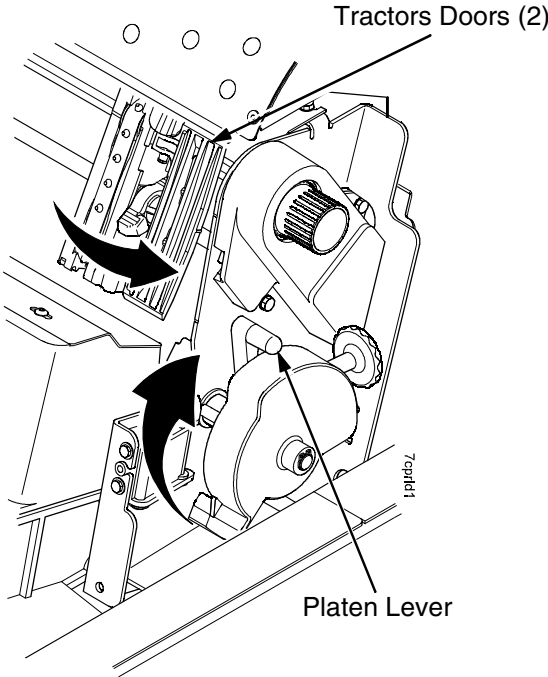

Figure 18. Completely Removing the Paper

- 8. To completely remove the paper from the printer:
 - a. Raise the platen lever as far as it will go and open both tractor doors.

CAUTION

Be careful when pulling any paper backward through the paper path, especially when using a label stock. If you are not careful, labels can detach and adhere to the printer within the paper path, where only an authorized service representative can remove them.

- b. Open the cabinet front door.
- c. Gently pull the paper down through the paper slot. Allow the paper to fall into the paper supply area.
- d. Remove the paper from the paper supply area.

Integrated Print Management System

The P7000's Integrated Print Management System feature automatically monitors and communicates the status of the ribbon's life to help the operator know when to change ribbons. Using a special bar coded spool, the P7000 automatically detects when a new or used ribbon is installed and determines the ribbon's length, ink color, and expected yield. The ribbon life, starting from 100% when new and decreasing to 0% when depleted, is always displayed on the control panel. See Figure 5 on page 28.

When the ribbon life reaches 2%, a warning message "RIBBON UNDER 2%/Change RBN soon" appears on the control panel display. The control panel status indicator lamp flashes. The printer will continue printing in this condition until the ribbon life reaches 0% at which time, printing will stop. The ribbon may be changed at any time while the printer is in the "RBN END POINT/Change Ribbon" condition without losing data in the printer's buffer. Simply follow the procedures outlined below to change the ribbon.

You may also resume printing for approximately two more minutes without changing the ribbon by pressing the ON LINE/CLEAR key twice. This may be done as many times as needed to complete the job in progress.

Lighter Or Darker Print

The ribbon life value as determined by the Integrated Print Management System is factory set so that the image quality at the end of the ribbon life is as good as it was when the ribbon was new. You may adjust the ribbon end point for a lighter or darker image as required for your printing needs. See "PRINTER CONTROL" on page 276.

Changing Ribbons

Before changing the ribbon, determine whether you want to make the print lighter (extend the ribbon life) or darker (shorten the ribbon life). If you want to make the print lighter, go to “Ribbon End Point” on page 277 and follow the procedures for adjusting the image density. If you are satisfied with the print darkness, or if you want to increase the darkness at the end of ribbon life, continue with the following steps.

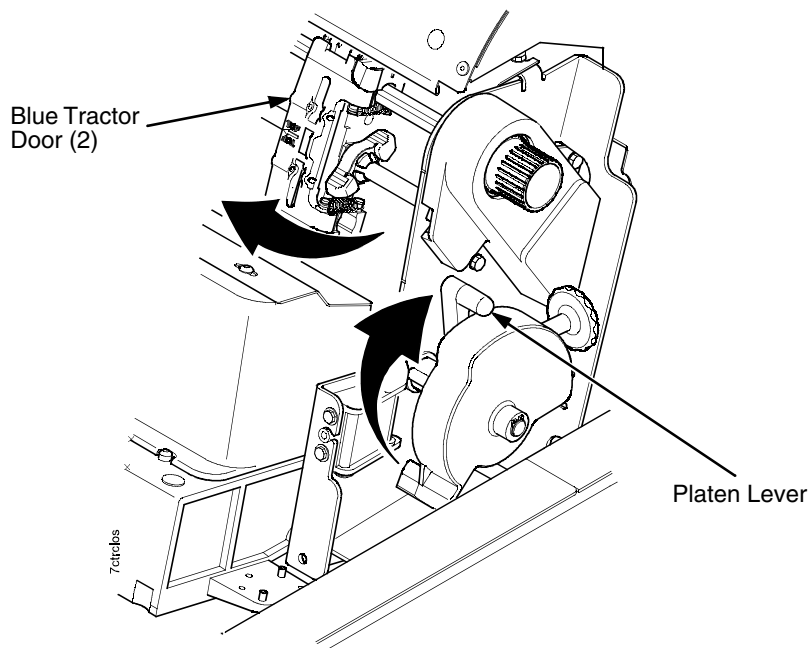

Figure 19. Preparing to Load the Ribbon

1. Open the printer cover.
2. Raise the platen lever as far as it will go.
3. Close the tractor doors.
4. Remove the old ribbon and discard properly.

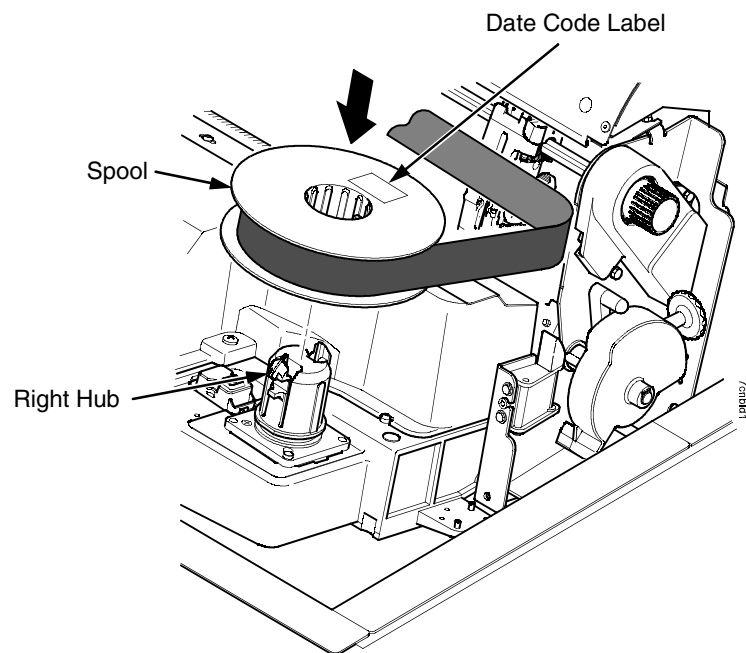

Figure 20. Loading the Barcoded Ribbon

5. Place the full spool on the right hand side ribbon hub and press it into place.

IMPORTANT

The full spool has a barcode label on the bottom side and a date code label on the top. Once the sensor reads and logs the ribbon barcode, the Integrated Print Management System starts to track ribbon usage. A date code label is on the top side of the right hand spool.

If you remove the ribbon during the course of its life and want to re-install the same ribbon, be sure to place the same spools on the correct hubs.

Changing Ribbons

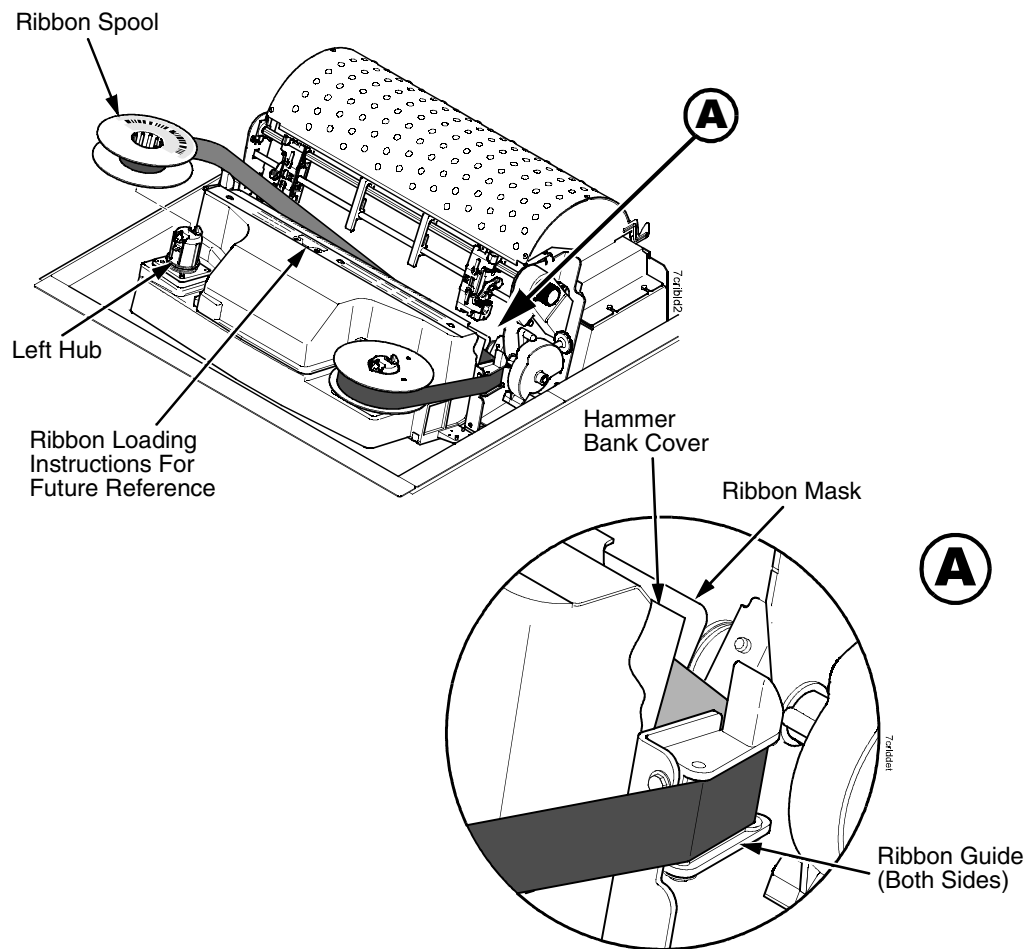

Figure 21. Threading the Ribbon Around the Ribbon Guide

6. Thread the ribbon around the ribbon guide and along the ribbon path. Be sure to thread the ribbon between the hammer bank cover and the ribbon mask.
7. Place the empty spool on the left hub.
8. Press the spool down until it snaps into place.

Chapter 3 Integrated Print Management System

9. Turn the left spool by hand to make sure the ribbon tracks correctly in the ribbon path and around the ribbon guides.
10. Close the platen lever.
11. Close the printer top cover.

If you want to increase the darkness level of the ribbon at the end of life, go to “Ribbon End Point” on page 277 and follow the procedures for adjusting the image density.

If you are satisfied with the print darkness, press the ON LINE/CLEAR key twice to return the printer to operation.

Cancel A Print Job

The procedure to cancel a print job depends on the printer emulation and your application software. Contact your system administrator for additional information.

1. If the printer is online, press ON LINE/CLEAR to place the printer in offline mode.
2. From the host system, stop the print job.

NOTE: If the print job is not stopped from the host system before pressing CANCEL, the print job continues with data missing when the printer returns to online mode. Exercise caution to prevent unwanted data loss occurrences, as this function deletes unprinted data in the printer. This function is active only in offline mode; the purpose of this function is to eliminate the necessity of printing unwanted data when print jobs are canceled.

3. Press CANCEL.

NOTE: You may need to enable the Cancel option on the front panel. See “ADVANCED USER” on page 281 for details.

4. Set the top-of-form. Refer to the Quick Setup Guide.

4

The Configuration Menus

Configuration Overview

To print data, the printer must respond correctly to signals and commands received from the host computer. Configuration is the process of matching the printer's operating characteristics to those of the host computer and to specific tasks, such as printing labels or printing on different sizes of paper. The characteristics which define the printer's response to signals and commands received from the host computer are called configuration parameters.

You can configure the printer using the configuration menus and the control panel or by sending control codes in the data stream from a host computer attached to the printer. This chapter provides an introduction to configuring the printer and includes the configuration menus available (depending on which emulation you have installed in the printer).

IMPORTANT

Configuration directly affects printer operation. Do not change the configuration of your printer until you are thoroughly familiar with the procedures in this chapter.

Changing Parameter Settings

You may change a printer parameter setting, such as line spacing or forms length, either by pressing keys on the control panel or by sending emulation control codes in the data stream from a host attached to the printer. The control panel allows you to configure the printer's resident set of configuration menus. An example procedure for using the control panel to change parameter settings begins on page 57.

When control codes are sent from a host attached to the printer, they override control panel settings. For example, if you set the line spacing to 6 lpi with the control panel, and application software later changes this to 8 lpi with a control code, the control code overrides the control panel setting.

Saving Parameter Settings

The parameter settings that you have changed using the menus and control codes will be permanently stored in the printer's memory. Changes made to the Factory Default configuration menu items will always be written to the first available Config (#) where # equals the next available unassigned configuration number and can be made with or without the Protect Config option disabled.

You may also save your new configurations using the PTX_SETUP command host control code. See your *LinePrinter Plus Programmer's Reference Manual* for details.

Default And Custom Configurations

A configuration consists of a group of parameter settings, such as line spacing, forms length, etc. Your printer provides a fixed default configuration and allows you to define several custom configurations for use with particular print jobs. The factory default configuration can be loaded, but it cannot be altered.

Eight configurations can be modified for unique print job requirements. The “Save Config.” option allows you to save eight groups of parameter settings in memory as custom configurations numbered from 1 through 8. An explanation on how to save a set of parameter values as a custom configuration using the “Save Config.” menu option begins on page 61.

Navigating The Menus

To manipulate configurations review the following instructions about navigating through the menus.

You must be offline to move within the menus.

ON LINE/CLEAR



Press to toggle between ONLINE and OFFLINE. Menus are accessed with the printer offline.



Press to move up or down through the menu levels.

OR



Press to scroll through the available choices on a chosen level.

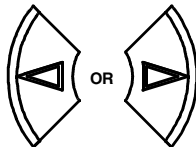

ENTER



Press to confirm selection.



Press to lock and unlock the ENTER key. The ENTER key is locked by default to prevent you from accidentally changing the printer configuration. The lock and unlock function can be configured to be other than ▲ + ▼ (See “Set Lock Key” on page 288.)

+



To experiment with navigating the menus, use the example on the next page as a tutorial.

Changing Parameters Example

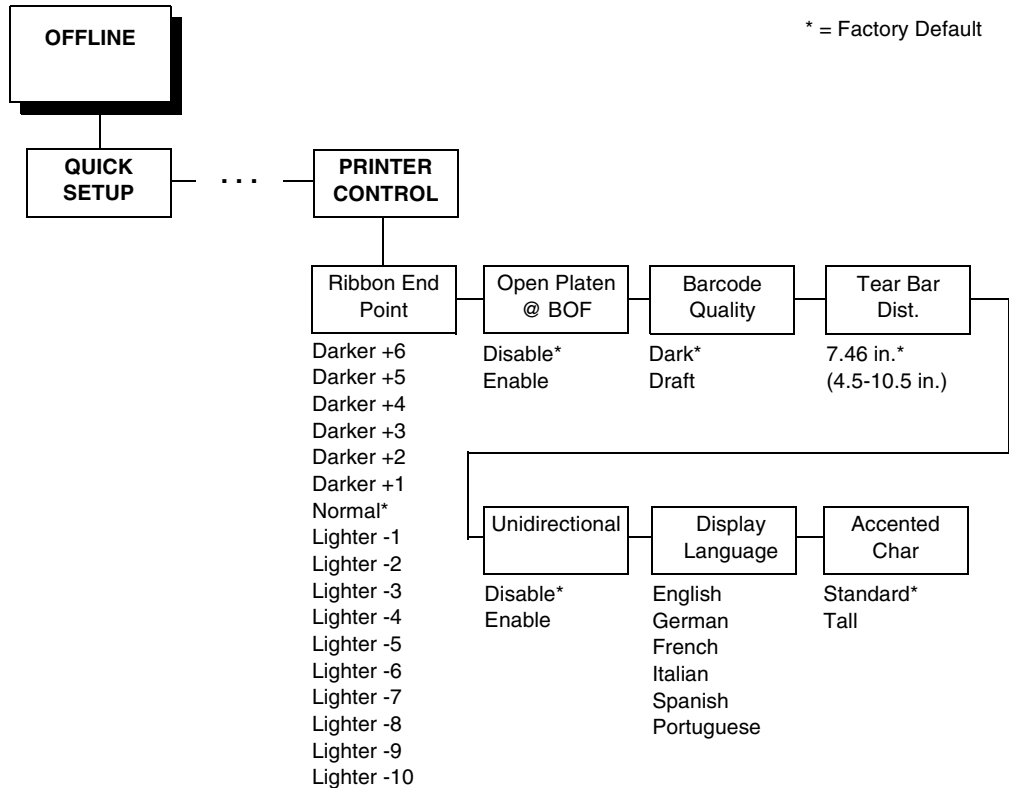







A configuration consists of several parameters. The default factory configuration has a starting set of parameters. In the configuration menu above, and in all the configuration menus in this chapter, the factory default values are indicated by an asterisk (*).







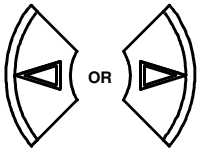

Your print jobs may require parameter values which vary from the default settings. This section provides an example procedure for changing individual parameter values.

The following procedure shows how to change and save the settings for the Barcode Quality and Language options. Use these guidelines to navigate the configuration menus and change other parameters.

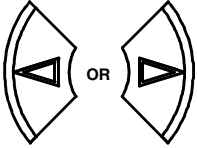

Chapter 4 Configuration Overview

Step	Press	LCD	Notes
1.	Make sure the printer is on.		
2.	ON LINE/CLEAR 	OFFLINE QUICK SETUP	Allows you to make configuration changes.
3.	 + 	ENTER SWITCH UNLOCKED	
		OFFLINE QUICK SETUP	
4.	 UNTIL	OFFLINE PRINTER CONTROL	
5.		PRINTER CONTROL Ribbon End Point	
6.	 UNTIL	PRINTER CONTROL Barcode Quality	
7.		Barcode Quality Dark*	

Changing Parameters Example

Step	Press	LCD	Notes
8.		Barcode Quality Draft	Cycle through the choices. The * indicates this choice is active. Press until the desired parameter displays. The * indicates this choice is active. Locks the ENTER key.
9.	ENTER 	Barcode Quality Draft*	
10.		PRINTER CONTROL Barcode Quality	
11.	 UNTIL	PRINTER CONTROL Display Language	
12.		Display Language English*	
13.		Display Language Spanish	
14.	ENTER 	Display Language Spanish*	
15.	 + 	ENTER SWITCH LOCKED	

Chapter 4 Configuration Overview

Step	Press	LCD	Notes
16.	ON LINE/CLEAR 	ENTER = Save ONLINE = No Save	Press ENTER to automatically save configuration changes. Press ONLINE to continue without saving.
17A.	ENTER 	Cfg = 1* = Power-Up Cfg	Configuration changes have been saved as Configuration 1, and will be set as the Power-Up config. The printer will then be brought online.
17B.	ON LINE/CLEAR 	ONLINE Ribbon Life = 100%	Places the printer online without permanently saving the configuration changes.
18.	The printer is ready for operation		

Auto Save Configuration

After any changes are made to the Factory Default configuration menu items, you will be prompted to save the changes to “Config #”, where # equals the next available unassigned configuration number. If you do not select this option, the printer will be brought ONLINE and the changes will be implemented but saved only temporarily until deliberately saved as a new configuration or until you power off the printer.

Saving Your New Configuration

The Save Config. option allows you to save up to eight custom configurations to meet different print job requirements. Once you have changed all of the necessary parameters, you may save them as a numbered configuration (Example 1 on page 62) or a named configuration (Example 2 on page 65) that can be stored and loaded later for future use. If you do not save your configuration using the Auto Save, or this option, all of your parameter changes will be erased when you power off the printer.







Once you have saved a custom configuration using this option, it will not be lost if you power off the printer. You can load a configuration for a specific print job (see “Load Config.” on page 82). You can also modify and resave it. You may want to print your configurations (see “Print Config.” on page 83) and store them in a safe place, such as inside the printer cabinet. If the Protect Configs. parameter is enabled and you try to resave an existing configuration, the new configuration will not be saved until the existing configuration has been deleted (see “Delete Config.” on page 83).

NOTE: Once you change active emulations, any changes to the previously selected emulation will be gone unless they have been saved.







Chapter 4 Configuration Overview

Example 1

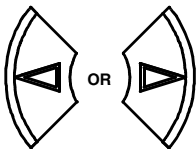

This example shows how to save a configuration as a numbered configuration, then later print it.

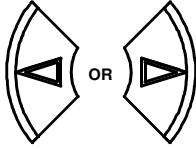
Step	Press	LCD	Notes
1.	Make sure the printer is on.		
2.	ON LINE/CLEAR 	OFFLINE CONFIG. CONTROL	
3.	 + 	ENTER SWITCH UNLOCKED	Allows you to make configuration changes.
		OFFLINE QUICK SETUP	
4.	 UNTIL	OFFLINE CONFIG. CONTROL	
5.		CONFIG. CONTROL Load Config.	
6.	 UNTIL	CONFIG. CONTROL Save Config.	
7.		Save Config. 1*	

Saving Your New Configuration

Step	Press	LCD	Notes
8.		Save Config. 2	Cycle through the choices.
9.	ENTER 	Save Config. 2*	The * indicates this choice is active.
NOTE: We recommend that you print the configuration. To print the configuration go to Step 9. To skip this procedure and resume printer operation, go to Step 14.			
10.		CONFIG. CONTROL Save Config.	
11.	 UNTIL	CONFIG. CONTROL Print Config.	
12.		Print Config. Current	
13.		Print Config. 2	Press until the desired parameter displays.
14.	ENTER 	OFFLINE CONFIG. CONTROL	The selected configuration is printed.







Chapter 4 Configuration Overview

Step	Press	LCD	Notes
15.	 + 	ENTER SWITCH LOCKED	Locks the ENTER key.
16.	ON LINE/CLEAR 	ONLINE Ribbon Life = 100%	
17.	If you printed out the configuration, store it in a safe place. The printer is ready for operation.		









Saving Your New Configuration

Example 2









This example shows how to save a configuration as a named configuration.

Step	Press	LCD	Notes
1.	Make sure the printer is on.		
2.	ON LINE/CLEAR 	OFFLINE CONFIG. CONTROL	
3.	 + 	ENTER SWITCH UNLOCKED	Allows you to make configuration changes.
		OFFLINE QUICK SETUP	
4.	 UNTIL	OFFLINE CONFIG. CONTROL	
5.		CONFIG. CONTROL Load Config.	
6.	 UNTIL	CONFIG. CONTROL Name Configs.	
7.		Name Configs. 1	The LCD flashes.



Chapter 4 Configuration Overview

Step	Press	LCD	Notes
8.	 UNTIL	Name Configs 2	You will rename config 2. Cycle through the choices until "T" displays. Saves the first character. Cycle through the choices until "E" displays. Saves the second character. Cycle through the choices until "S" displays. Saves the third character.
9.		2 2*	
10.	 UNTIL	2 T	
11.		2 T_	
12.	 UNTIL	2 TE	
13.		2 TE_	
14.	 UNTIL	2 TES	
15.		2 TES_	

Saving Your New Configuration

Step	Press	LCD	Notes
16.	 UNTIL	2 TEST	Cycle through the choices until "T" displays.
17.		2 TEST_	
18.	ENTER 	Name Configs TEST	The configuration is renamed TEST.
19.		CONFIG. CONTROL Name Configs	
20.	 UNTIL	CONFIG. CONTROL Save Config.	TEST now appears as one of configuration choices.
21.		Save Config. 1*	
22.		Save Config. TEST	
23.	ENTER 	Saving Configuration	Your configuration is saved as TEST.
		Save Config. TEST*	

Chapter 4 Configuration Overview

Step	Press	LCD	Notes
24.	 + 	ENTER SWITCH LOCKED	Locks the ENTER key.
25.	ON LINE/CLEAR 	ONLINE Ribbon Life = 100%	

Now you have the saved configuration for later use if needed.

Optimizing Print Quality

LP+, IGP/PGL, and IGP/VGL Emulations

You can optimize print quality for darker and sharper barcodes and characters. Doing so, however, will decrease the printer speed.

To optimize print quality, you can change the values of the following configuration parameters:

- **Bar Code Quality (Printer Control menu):** Select “Dark” or “Recommended.” Recommended prints the darkest images, but at the slowest speed. Dark prints at a faster speed than Recommended, but the characters are not as dark. (See page 279 for a written description of Bar Code Quality.)
- **Print Quality (IGP/PGL emulation):** Select “Best” or “High.” Best prints the darkest images, but at the slowest speed. High prints at a faster speed than Best, but the characters are not as dark. (See page 129 for the IGP/PGL Configuration Menu, and see page 143 for a written description of Print Quality.)
- **Print Quality (IGP/VGL emulation):** Select “High.” (See page 148 for the IGP/VGL Configuration Menu, and see page 157 for a written description of Print Quality.)

Optimizing Print Speed

LP+, IGP/PGL, and IGP/VGL Emulations

The printer has been configured at the factory for optimal print speed. To optimize print quality instead, you can change values for specific configuration parameters such as Barcode Quality and Print Quality. Doing so, however, will decrease the printer speed.

If you have optimized the printer for print quality, you can change it to optimal speed by selecting the values as follows:

- **Bar Code Quality (Printer Control menu):** Select “Draft.”
(See page 70 for the Configuration Main Menu, and see page 279 for a written description of Bar Code Quality.)
- **Print Quality (IGP/PGL emulation):** Select “Dataprocessing.”
(See page 129 for the IGP/PGL Configuration Menu, and see page 143 for a written description of Print Quality.)
- **Print Quality (IGP/VGL emulation):** Select “Dataprocessing.”
(See page 148 for the IGP/VGL Configuration Menu, and see page 157 for a written description of Print Quality.)

Coax/Twinax Emulation

You can increase print speed by selecting the Enable mode for the Early Print Complete configuration parameter in the Coax/Twinax Emulation. However, if an error occurs while in Enable mode, you may lose data. For more information, refer to “Early Print Complete” on page 172. (For the Coax/Twinax Emulation menu, refer to page 167.)

Chapter 4 Main Menu

Main Menu

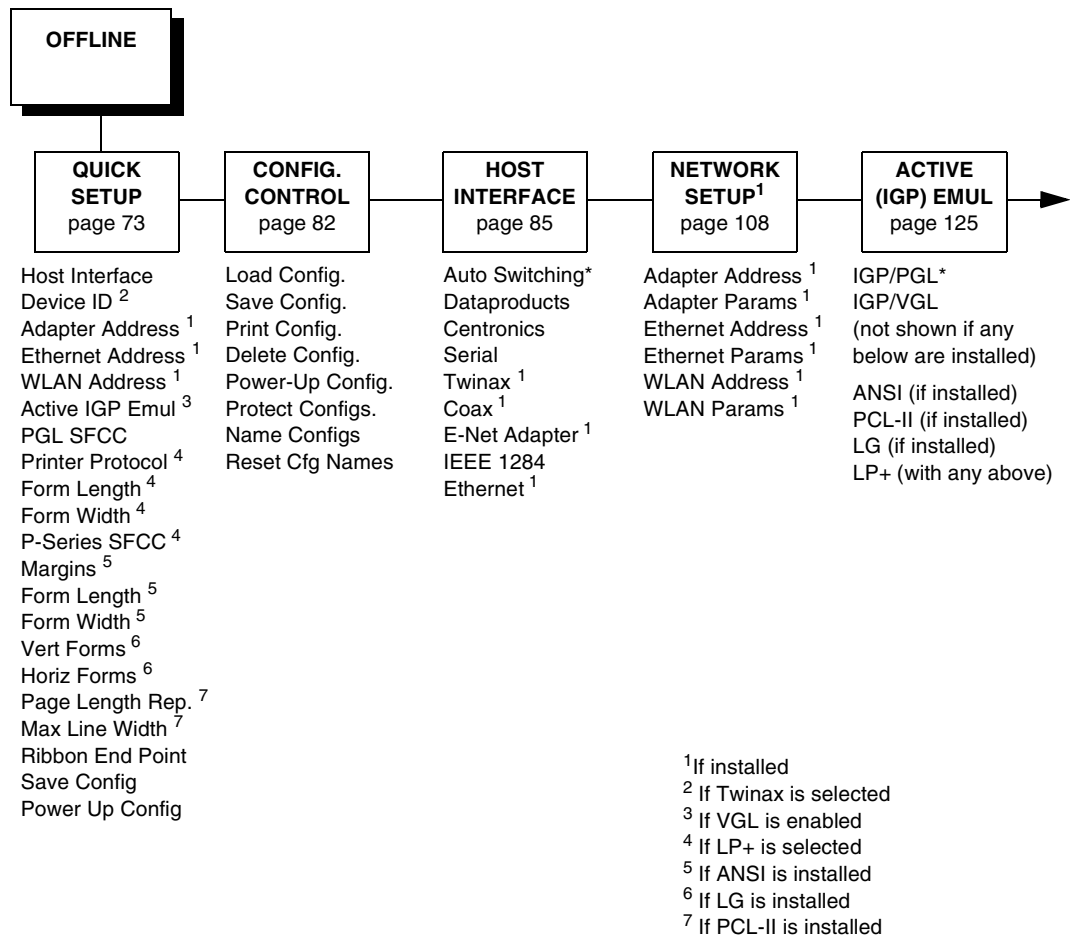
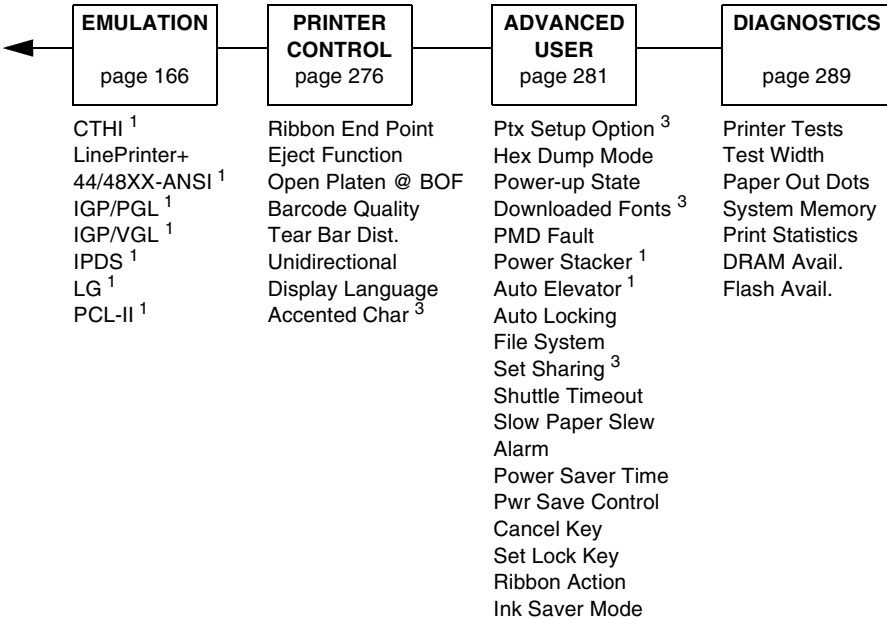

Figure 22. Main Menu Configuration



¹If installed
²If Ethernet is installed
³Not available in LG or PCL-II

Chapter 4 Main Menu

Brief descriptions follow for the first-level configuration menu options:

- **QUICK SETUP** — These options allow quick access to the most frequently changed or inputted parameters during the installation of the printer.
- **CONFIG. CONTROL** — These options allow you to save, print, load, delete, name, and reset entire sets of configuration parameters.
- **HOST INTERFACE** — These options allow you to select either the Serial RS-232, Serial RS-422, Centronics[®] parallel, Dataproducts[®] parallel and Long Lines, Ethernet[™], IEEE[®] 1284 parallel, Auto Switching, Coax or Twinax interface for the printer. This menu also allows you to configure several parameters for each interface.
- **NETWORK SETUP** — This option allows you to select from Ethernet Address options and Ethernet Parameters options.
- **ACTIVE (IGP) EMUL** — This menu allows you to select the PGL or VGL emulation from the menu if IGP is installed.
- **EMULATION** — This menu allows you to configure the options which are available for the current operating (active) emulation. For example, if LinePrinter+ is the active emulation, then the LinePrinter+ emulation options can be configured using this menu.
- **PRINTER CONTROL** — These options allow you to select parameters common to a general user, such as display language and Barcode quality.
- **ADVANCED USER** — These options allow you to select several advanced operating parameters for the printer, such as the speed at which paper will advance when slewing.
- **DIAGNOSTICS** — These options include the diagnostic tests, system memory, and statistics of the printer.

QUICK SETUP

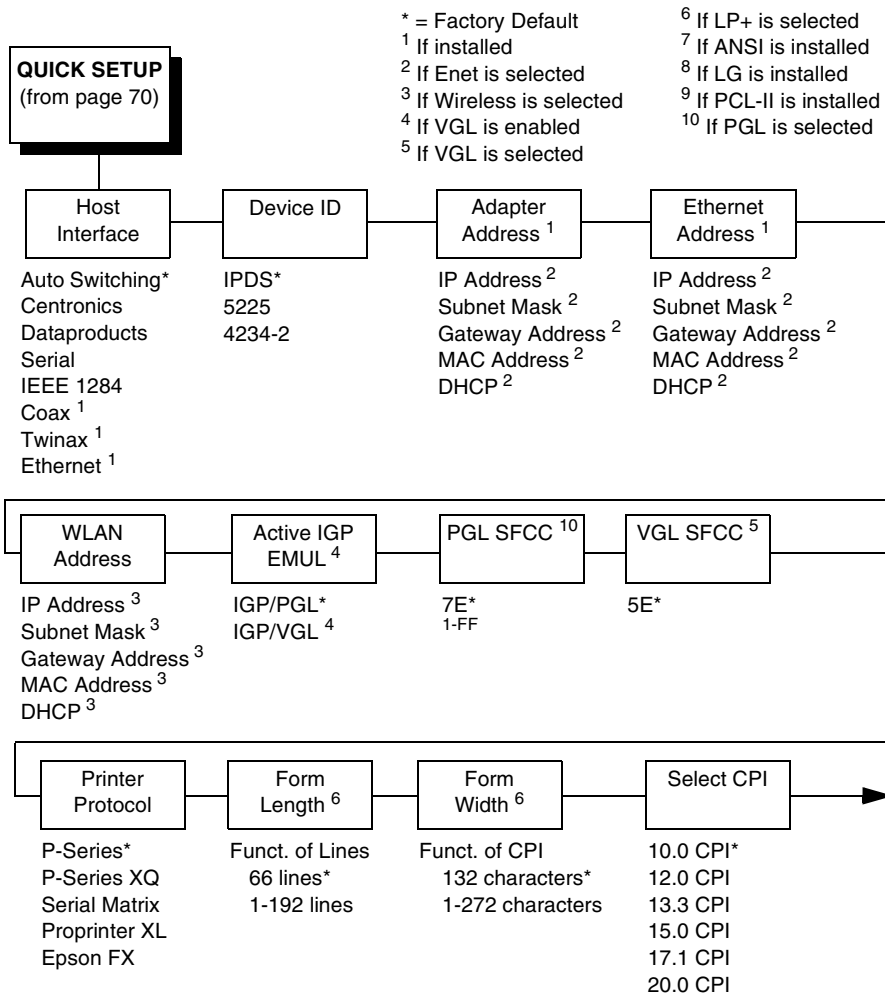

Chapter 4 QUICK SETUP

QUICK SETUP (continued)

* = Factory Default

¹ If installed

² If Enet is selected

³ If Wireless is selected

⁴ If VGL is enabled

⁵ If VGL is selected

⁶ If LP+ is selected

⁷ If ANSI is installed

⁸ If LG is installed

⁹ If PCL-II is installed

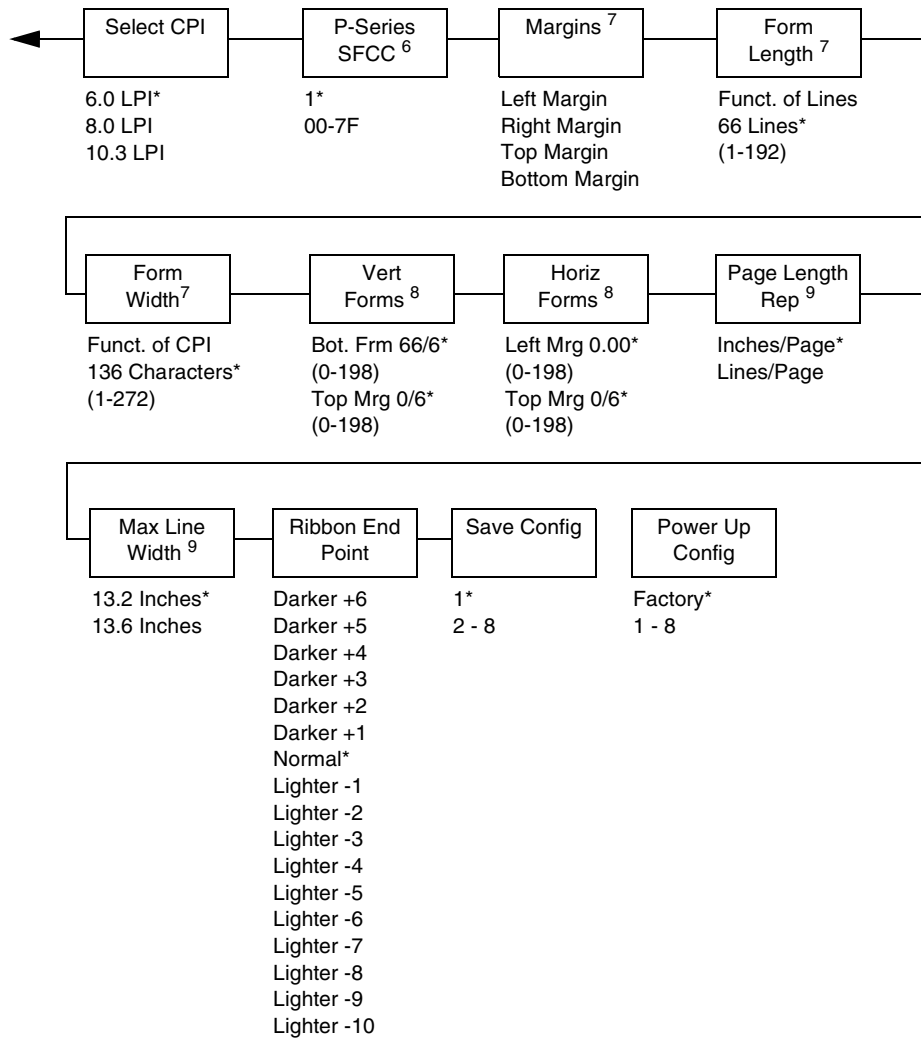

Host Interface

The Host Interface menu enables you to select and configure interfaces between the printer and your host computer.

Device ID

This parameter defines the printer emulation as IPDS, 4234-2 or 5225. After the emulation has been changed, a POR status is sent to the host. IPDS is the default.

Adapter Address

- **IP Address.** A numeric address such as 123.45.61.23 which identifies a printer or server in a LAN or WAN.
- **Subnet Mask.** A binary value used to divide IP networks into smaller subnetworks or subnets. This mask is used to help determine whether IP packets need to be forwarded to other subnets.
- **Gateway Address.** A gateway address is the IP address of a hardware device (gateway) that translates data between two incompatible networks, which can include protocol translation.
- **MAC Address.** This menu item is the Manufacturer's Assigned Number, and is unique for each printer. It is read-only.
- **DHCP.** You can enable/disable the DHCP protocol using this option, but consult your administrator for the appropriate setting.

Ethernet Address

- **IP Address.** A numeric address such as 123.45.61.23 which identifies a printer or server in a LAN or WAN.
- **Subnet Mask.** A binary value used to divide IP networks into smaller subnetworks or subnets. This mask is used to help determine whether IP packets need to be forwarded to other subnets.
- **Gateway Address.** A gateway address is the IP address of a hardware device (gateway) that translates data between two incompatible networks, which can include protocol translation.
- **MAC Address.** This menu item is the Manufacturer's Assigned Number, and is unique for each printer. It is read-only.
- **DHCP.** You can enable/disable the DHCP protocol using this option, but consult your administrator for the appropriate setting.

WLAN Address

- **IP Address.** A numeric address such as 123.45.61.23 which identifies a printer or server in a LAN or WAN.
- **Subnet Mask.** A binary value used to divide IP networks into smaller subnetworks or subnets. This mask is used to help determine whether IP packets need to be forwarded to other subnets.
- **Gateway Address.** A gateway address is the IP address of a hardware device (gateway) that translates data between two incompatible networks, which can include protocol translation.
- **MAC Address.** This menu item is the Manufacturer's Assigned Number, and is unique for each printer. It is read-only.
- **DHCP.** You can enable/disable the DHCP protocol using this option, but consult your administrator for the appropriate setting.

Active IGP Emulation

The Active Emulation menu enables you to activate either the PGL or VGL emulation.

PGL SFCC

You can specify which hex code (1-FF) will be used as the Special Function Control Character (SFCC). The SFCC denotes that the following data is an IGP command.

- **7E** (the default)
- **1 – FF**

VGL SFCC

You can specify which hex code (1-FF) will be used as the Special Function Control Character (SFCC). The SFCC denotes that the following data is an IGP command.

- **5E** (the default)
- **1 – FF**

Printer Protocol

Select the LinePrinter+ protocol you wish to use. Refer to the *LinePrinter Plus Programmer's Reference Manual* for more information.

Form Length

Form length is the number of lines that can be printed on a page. You can set the form length in inches, millimeters (mm), or as a function of the current lpi (lines per inch).

Form Width

The form width can be specified in inches, millimeters, or as a function of the current cpi (characters per inch). The forms width set should not exceed the actual paper width.

Select CPI

This parameter lets you specify the characters per inch (cpi) values.

Select LPI

This parameter lets you specify the lines per inch (lpi) values.

P-Series SFCC

This parameter allows you to select which ASCII codes will function as the Special Function Control Code (SFCC) command delimiter. P-Series codes can use hex 00 through hex 7F. Options include the following:

- **SOH (hex 01)** (the default)
- **ESC (hex 1B)**
- **ETX (hex 03)**
- **CIRCUMFLEX (hex 5E)** – also called caret (^)
- **TILDE (hex 7E)** – (~)

NOTE: SOH, ETX, and ESC are non-printables. The characters (^) and (~) are printable; however, do not use them as printables in the host data stream if either is chosen as a delimiter because print errors will occur.

Margins

- **Left Margin.** Set in columns. Column zero is defined as the far left edge of the page, and column numbering increments from left to right.
- **Right Margin.** Set in columns. Column zero is defined as the far right edge of the page, and column numbering increments from right to left.
- **Top Margin.** Defined in lines, starting from line zero at the top of the page and incrementing from the top down.
- **Bottom Margin.** Defined in lines, starting from line zero at the bottom of the page and incrementing from the bottom up.

Form Length

Form length is the number of lines that can be printed on a page. You can set the form length in inches, millimeters (mm), or as a function of the current lpi (lines per inch).

Form Width

The form width can be specified in inches, millimeters, or as a function of the current cpi (characters per inch). The forms width set should not exceed the actual paper width.

Vert Forms

- **Bot Frm 66/6** (default). This option sets the bottom margin for the forms. You must specify the bottom margin in lines (at 6 lines per inch), ranging from 0 to 198 lines (33 inches). The default setting is 66. Press the right arrow to increase the value, left arrow to decrease the value, and ENTER to change units. Selecting a value for this option resets the top margin to 0, so the top margin must be redefined after this option is selected.
- **Top Mrg 6/0** This option sets the top margin for the forms. You must specify the top margin in lines (at 6 lines per inch), ranging from 0 to 198 lines (33 inches). The default setting is 0. Press the right arrow to increase the value, left arrow to decrease the value, and ENTER to change units. The margins will automatically adjust so that the top and bottom margins do not cross each other.

Horiz Forms

- **Left Mrg 0.00** (default). This sets the left margin for the forms. You must specify the left margin in 1/10 inch increments, from 0 to 13.1 inches. The default value is 0. Press the right arrow to increase the value, left arrow to decrease the value, and ENTER to change units. The margins will automatically adjust so that the left and right margins do not cross each other.
- **Right Mrg 0/6**. This sets the right margin for the forms. You must specify the right margin in 1/10 inch increments, from 0.1 to 13.2 inches. The default value is 13.2. Press NEXT to increase the value, PREV to decrease the value, and ENTER to change units. The margins will automatically adjust so that the left and right margins do not cross each other.

Page Length Rep

- **Inches/Page** (default). Allows the user to set the page length in inches.
- **Lines/Page**. Allows the user to set the page length in number of lines.

Max Line Width

Set the maximum line width at either 13.2 inches or the maximum width of the printer.

Ribbon End Point

This parameter adjusts the point at which the system will declare the ribbon as being expended. The life count will always be from 100% to 0%, but if a darker setting is selected 0% will be reached more quickly. If a lighter setting is selected, the system will extend the time it takes to reach 0%.

Save Config

This option allows you to save up to eight configurations to meet different print job requirements. This eliminates the need to change the parameter settings for each new job. The configurations are stored in memory and will not be lost if you turn off the printer. If the Protect Configs. parameter is enabled, the new configuration will not be saved unless the existing configuration has been deleted first. The factory default configuration cannot be changed. See “Saving Your New Configuration” on page 61 for details.

Power Up Config

This option allows you to specify which of the nine configurations (Factory or 1-8) will be the power-up configuration.

Chapter 4 CONFIG. CONTROL

CONFIG. CONTROL

The CONFIG. CONTROL menu allows you to control your printer's configurations according to the specifications necessary for your print jobs.

* = Factory Default

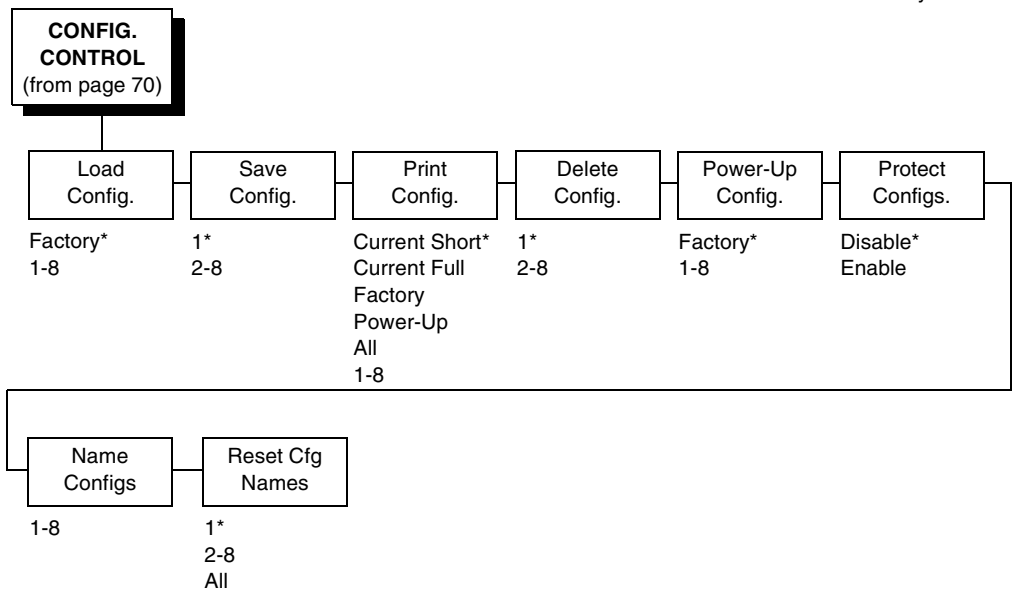

Load Config.

The printer can store numerous configurations in memory. This parameter allows you to select and load a specific configuration.

Save Config.

This option allows you to save up to eight configurations to meet different print job requirements. This eliminates the need to change the parameter settings for each new job. The configurations are stored in memory and will not be lost if you turn off the printer. If the Protect Configs. parameter is enabled, the new configuration will not be saved unless the existing configuration has been deleted first. The factory default configuration cannot be changed. See “Saving Your New Configuration” on page 61 for details.

Print Config.

This option is used to print a listing of various stored printer configurations. Store printouts of your configurations in a safe place for quick referral.

Delete Config.

You can delete one or all of your eight customized configurations. The factory default configuration cannot be deleted.

Power-Up Config.

You can specify which of the nine configurations (Factory or 1-8) will be the power-up configuration.

Protect Configs.

You can specify whether or not a new configuration should overwrite an existing configuration when you activate the Save Configs. parameter. When disabled (default), the new configuration will overwrite the existing configuration. When enabled, the new configuration will *not* overwrite the existing configuration, and the message “CONFIG. EXISTS / Delete First” displays.

Name Configs

You may specify a 15-character name which can be used to refer to a configuration. The name you enter for a configuration will be used in the Load Config., Save Config., Print Config., Delete Config., and Power-Up Config. menus. The name can only be cleared by using the Reset Cfg Names menu.

When you move into the Name Configs. menu, the top line of the display shows the current configuration name. The second line of the display is initially the same as the top line. You can modify the second line of the display without affecting the top line until the ENTER key is pressed, which sets the modified name.

Press the UP or DOWN (▲ or ▼) keys to cycle through the values available for that character at the cursor location. Press the NEXT (▶) key to move to the next character to be modified. Press the PREV key (◀) to go back to a character you have already modified. Continue until you have entered the name you want to give to this configuration, then press ENTER to save. The name you entered will now represent this configuration on the printer's front panel. To exit this menu without saving, press any key other than the ENTER key. The configuration name will revert to the last saved value.

Reset Cfg Names

You can reset specific configuration names back to the default value of the configuration number.

HOST INTERFACE

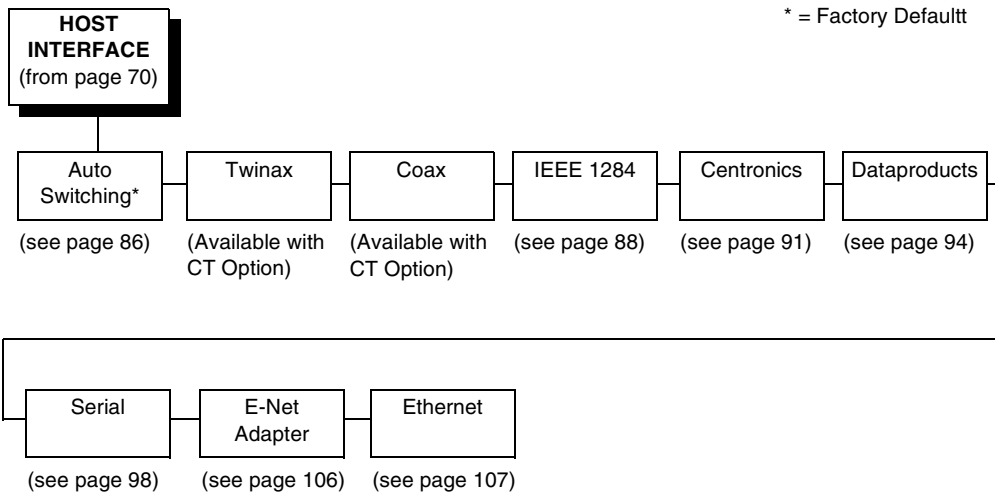

The Host Interface Menu enables you to select and configure one of many types of interfaces between the printer and your host computer. The currently selected interface is indicated with an asterisk on the control panel message display. Each interface has its own submenu with a set of interface parameters which can be configured.

IMPORTANT When switching between Twinax, Coax, or Auto Switching, the printer will load the power-up configuration and the new interface parameters. Any settings made and not saved before selecting these interfaces will be lost.

Auto Switching Submenu

Auto Switching
(from page 85)

* = Factory Default
¹If Installed

Parallel Hotport	Serial Hotport	Ethernet Hotport ¹	C/T Hotport ¹
Port Type	Port Type	Timeout	Port Type
Centronics*	RS 232*	10 sec.*	Twinax*
(see page 91 for options)	RS 422	(10-60)	Coax
Dataproducts	Disable		Disable
(see page 94 for options)	Trickle Time		Timeout
IEEE 1284	1/4 sec*		10 sec.*
(see page 88 for options)	1/2 sec		(10-60)
Disable	1 sec		Report Status
E-Net Adapter	2 sec		Disable*
(see page 106 for options)	4 sec		Enable
Trickle Time	8 sec		
1/4 sec*	16 sec		
1/2 sec	Off		
1 sec	Timeout		
2 sec	10 sec.*		
4 sec	(10-60)		
8 sec	Report Status		
16 sec	Disable*		
Off	Enable		
Timeout			
10 sec.*			
(10-60)			
Report Status			
Disable*			
Enable			

Auto Switching

Gives the printer the ability to handle multiple data streams sequentially. With Auto Switching, the printer can service hosts attached to the serial, parallel, Ethernet, coax and twinax ports as if they were the only interface connected.

For example, if the host computer sends one print job to the RS-232 serial port and a separate print job to the IEEE 1284 parallel port, the printer's Auto Switching is able to handle both jobs, in the order they were received. The user does not have to reconfigure the selected interface between jobs.

Port Type

Select the types of parallel, serial and/or C/T interfaces which are connected to the printer. For example, if your printer is attached to one host with a Centronics connection and a second host with an RS-422 serial connection, you would select Centronics under the Parallel Hotport menu, RS-422 under the Serial Hotport menu, and Disable under the C/T Hotport menu.

Trickle Time

When the printer is printing data from a host and a second job is received by the printer from a different host, Trickle Time prevents the second host from timing out while it is waiting for its data to be printed. In order to support this feature, the port has to be able to accept data from the host and store it for future use.

For example, if the printer is printing a job from the serial port, and then receives a second print job from the parallel port, the data from the parallel port will "trickle" bit by bit into the printer buffer to prevent a timeout error from being sent back to the host connected to the parallel port.

The selected value is the time that the printer waits before getting the next byte of data from the host. The Trickle Time value should be less than the host time out value, but not too much shorter or else the printer fills up its buffer too fast. This function is not applicable for C/T hotport.

Timeout

This is the value used by the printer to time out from the current port and check the other selected port types for data to print. When the printer has not received data from the host after a certain period of time, it needs to timeout in order to service the other ports.

Report Status

- **Disable** (default). When a fault occurs on the printer, only the active port reports the fault to the host.
- **Enable**. The port will report any fault even when it is not the current active port.

IEEE 1284 Parallel (Bidirectional) Submenu

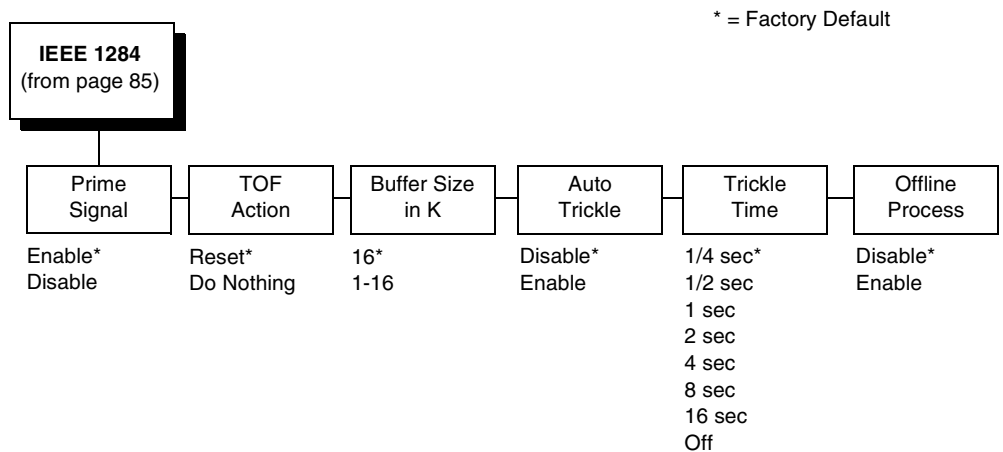

The IEEE 1284 interface is faster and more versatile than Centronics and supports bidirectional communication. Configuration of this interface is controlled from the host. Refer to “IEEE 1284 Parallel Interface” on page 298 more details about the available modes (Compatibility, Nibble, and Byte).

Prime Signal

- **Disable** (default). The parallel port will not perform a warm start (reboot) if the host asserts the prime signal.
- **Enable**. The parallel port will perform a warm start (reboot) if the host asserts the prime signal.

TOF Action

- **Reset** (default). A form feed is performed before a warm start when the prime signal is asserted from the host. This setting is used only if the prime signal parameter is enabled.
- **Do Nothing**. Nothing occurs before a warm start when the prime signal is asserted from the host.

Buffer Size in K

This option configures the amount of memory allocated for the IEEE 1284 parallel port buffer. You can specify between 1 and 16 Kbytes, in 1-Kbyte increments.

Auto Trickle

Auto Trickle is used to prevent a host computer from timing out because the parallel interface was busy for too long. When Auto Trickle is enabled and the printer's buffers are almost full, the printer will begin to trickle data in (at the rate set in the Trickle Time menu) until the buffers start to empty out.

Trickle Time

When the printer is printing data from a host and a second job is received by the printer from a different host, Trickle Time prevents the second host from timing out while it is waiting for its data to be printed. In order to support this feature, the port has to be able to accept data from the host and store it for future use.

Chapter 4 HOST INTERFACE

For example, if the printer is printing a job from the serial port, and then receives a second print job from the parallel port, the data from the parallel port will “trickle” bit by bit into the printer buffer to prevent a timeout error from being sent back to the host connected to the parallel port.

The selected value is the time that the printer waits before getting the next byte of data from the host. The Trickle Time value should be less than the host time out value, but not too much shorter or else the printer fills up its buffer too fast. This function is not applicable for C/T hotport.

Offline Process

- Disable (the default). When set to disable, the printer does not process parallel/network data while offline.
- Enable. When set to enable, the printer continues to process (but not print) the current network/parallel job while the printer is offline until the printer's buffer is full.

Centronics (Parallel) Submenu

* = Factory Default

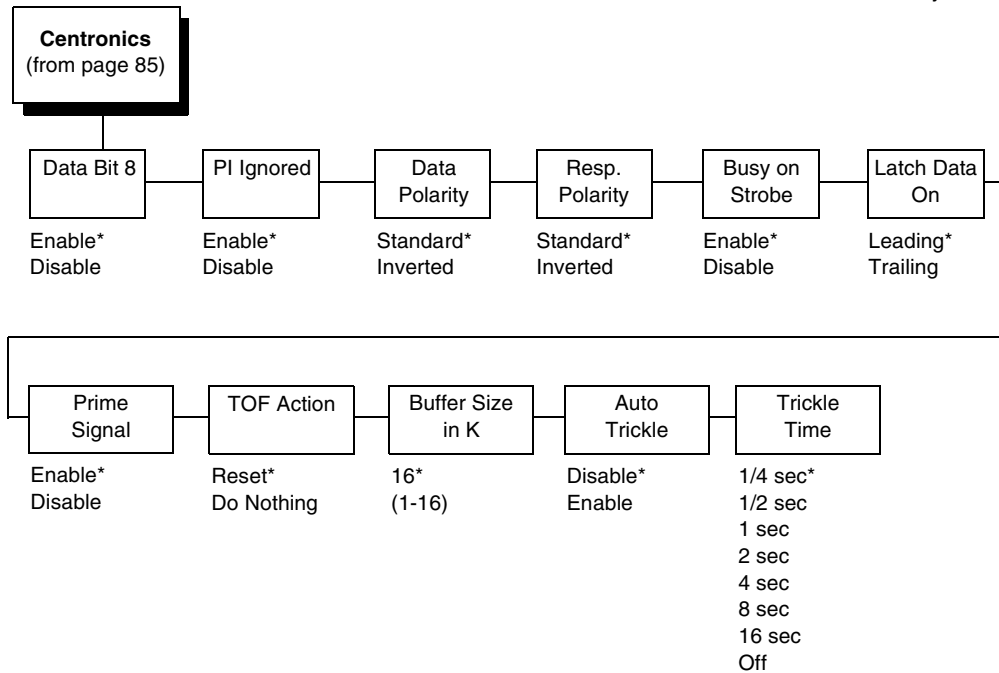

Data Bit 8

- **Enable** (default). Allows access to the extended ASCII character set.
- **Disable**. The printer interprets bit 8 of each incoming data character as a zero, regardless of its actual setting.

PI Ignored

The PI (Paper Instruction) signal is used to control vertical paper motion.

- **Enable** (default). Ignores the PI signal and treats the data as characters or control codes.
- **Disable**. Causes the printer to interpret the eight data lines as VFU commands when the PI signal is true.

Data Polarity

The Data Polarity parameter must be set to match the data polarity of your host computer.

- **Standard** (default). Does not expect the host computer to invert the data.
- **Inverted**. Expects the data received on the data lines from the host computer to be inverted. Ones become zeros, and vice versa.

Resp. Polarity

The Resp. Polarity parameter must be set to match the response polarity of your host computer.

- **Standard** (default). Does not invert the response signal.
- **Inverted**. Inverts the response signal sent to the host computer.

Busy On Strobe

- **Enable** (default). Asserts a busy signal after each character is received.
- **Disable**. Asserts a busy signal only when the print buffers are full.

Latch Data On

Specifies whether the data is read on the leading or trailing edge of the data strobe signal.

Prime Signal

- **Enable** (default). The parallel port will perform a warm start (reboot) if the host asserts the prime signal.
- **Disable**. The parallel port will not perform a warm start (reboot) if the host asserts the prime signal.

TOF Action

- **Reset** (default). A form feed is performed before a warm start when the prime signal is asserted from the host. This setting is used only if the prime signal parameter is enabled.
- **Do Nothing**. Nothing occurs before a warm start when the prime signal is asserted from the host.

Buffer Size in K

Configures the amount of memory allocated for the Centronics parallel port buffer. You can specify between 1 and 16 Kbytes, in 1-Kbyte increments.

Auto Trickle

Auto Trickle is used to prevent a host computer from timing out because the parallel interface was busy for too long. When Auto Trickle is enabled and the printer's buffers are almost full, the printer will begin to trickle data in (at the rate set in the Trickle Time menu) until the buffers start to empty out.

Trickle Time

When the printer is printing data from a host and a second job is received by the printer from a different host, Trickle Time prevents the second host from timing out while it is waiting for its data to be printed. In order to support this feature, the port has to be able to accept data from the host and store it for future use.

Chapter 4 HOST INTERFACE

For example, if the printer is printing a job from the serial port, and then receives a second print job from the parallel port, the data from the parallel port will “trickle” bit by bit into the printer buffer to prevent a timeout error from being sent back to the host connected to the parallel port.

The selected value is the time that the printer waits before getting the next byte of data from the host. The Trickle Time value should be less than the host time out value, but not too much shorter or else the printer fills up its buffer too fast. This function is not applicable for C/T hotport.

Dataproducts (Standard) Submenu

* = Factory Default

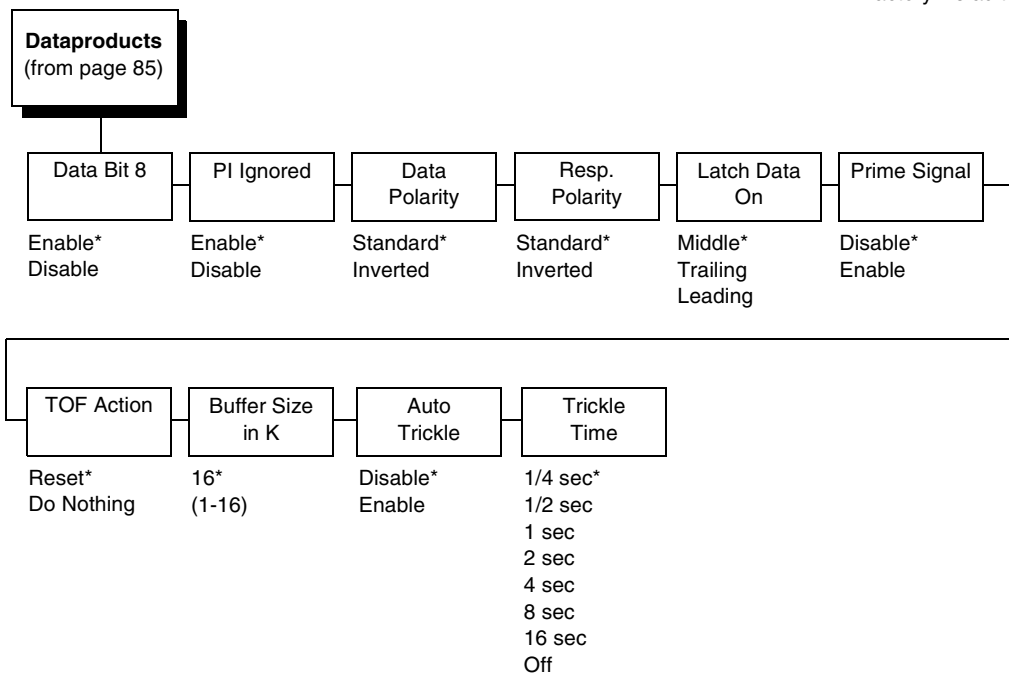

Data Bit 8

- **Enable** (default). Allows access to the extended ASCII character set.
- **Disable**. The printer interprets bit 8 of each incoming data character as a zero, regardless of its actual setting.

PI Ignored

The PI (Paper Instruction) signal is used to control vertical paper motion.

- **Enable** (default). Causes the printer to interpret the eight data lines as DVFU commands when the PI signal is true.
- **Disable**. Ignores the PI signal and treats the data as characters or control codes.

Data Polarity

The Data Polarity parameter must be set to match the data polarity of your host computer.

- **Standard** (default). Does not expect the host computer to invert the data.
- **Inverted**. Expects the data received on the data lines from the host computer to be inverted. Ones become zeros, and zeros become ones.

Resp. Polarity

The Response Polarity parameter must be set to match the response polarity of your host computer.

- **Standard** (default). Does not invert the response signal.
- **Inverted**. Inverts the response signal sent to the host computer.

Latch Data On

Specifies whether the data is read on the leading, middle, or trailing edge of the data strobe signal. The default is Middle.

Prime Signal

- **Disable** (default). The parallel port will not perform a warm start (reboot) if the host asserts the prime signal.
- **Enable**. The parallel port will perform a warm start (reboot) if the host asserts the prime signal.

TOF Action

- **Reset** (default). A form feed is performed before a warm start when the prime signal is asserted from the host. This setting is used only if the prime signal parameter is enabled.
- **Do Nothing**. Nothing occurs before a warm start when the prime signal is asserted from the host.

Buffer Size in K

Configures the amount of memory allocated for the Dataproducts parallel port buffer. You can specify between 1 and 16 Kbytes, in 1-Kbyte increments.

Auto Trickle

Auto Trickle is used to prevent a host computer from timing out because the parallel interface was busy for too long. When Auto Trickle is enabled and the printer's buffers are almost full, the printer will begin to trickle data in (at the rate set in the Trickle Time menu) until the buffers start to empty out.

Trickle Time

When the printer is printing data from a host and a second job is received by the printer from a different host, Trickle Time prevents the second host from timing out while it is waiting for its data to be printed. In order to support this feature, the port has to be able to accept data from the host and store it for future use.

Dataproducts (Standard) Submenu

For example, if the printer is printing a job from the serial port, and then receives a second print job from the parallel port, the data from the parallel port will “trickle” bit by bit into the printer buffer to prevent a timeout error from being sent back to the host connected to the parallel port.

The selected value is the time that the printer waits before getting the next byte of data from the host. The Trickle Time value should be less than the host time out value, but not too much shorter or else the printer fills up its buffer too fast. This function is not applicable for C/T hotport.

Chapter 4 HOST INTERFACE

Serial Submenu

* = Factory Default

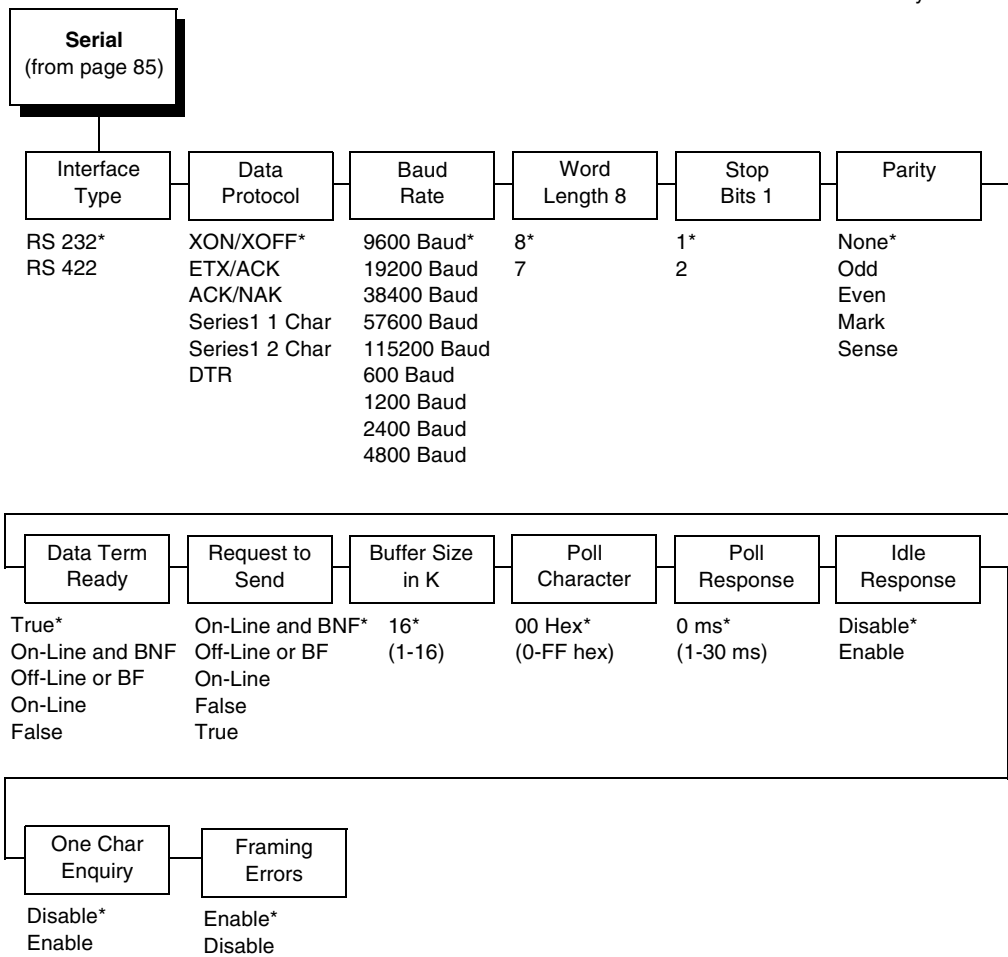

Interface Type

This parameter allows you to select either the RS-232 or RS-422 serial port interface.

Data Protocol

You can select one of the following serial interface protocols to meet the host interface requirements.

- **XON / XOFF** (default). The printer controls the flow of communication from the host by turning the transmission on and off. In some situations, such as when the buffer is full or the timing of signals is too slow or too fast, the printer will tell the host to stop transmission by sending an XOFF character. An XOFF character is sent when the number of empty bytes in the buffer is less than or equal to 25 percent of the buffer size. If the host keeps sending data after an XOFF is sent, the printer firmware will continue to send an XOFF for every 16 characters received. When cleared, the printer will resume receiving data (XON). The data does not have any End of Text codes; XON / XOFF is a non-block protocol.
- **ETX / ACK**. End of Text / Acknowledge. The host controls the flow of communication to the printer by sending a block of data and ending the block with an End of Text (ETX) signal. When the printer receives the ETX signal, it will acknowledge the ETX, thereby acknowledging it has received the entire block of data.
- **ACK / NAK**. ACK means acknowledge; the device acknowledges it has accepted a transmission. NAK means negative acknowledge; the device did not receive the transmission.

SERIES1 1 CHAR. The printer controls the flow of communication from the host by turning the transmission on and off using response characters sent to the host. If the number of valid bytes in the buffer reaches 75 percent of the buffer size, the online or offline and buffer full response character is sent. If the buffer is completely full, an online or offline buffer full response is sent every time a character is sent from the host. Whenever the printer state changes to online or offline, the appropriate response character is sent. If the idle response option is enabled, the printer will send a response character every two seconds while the number of valid bytes in the buffer is less than 75 percent of the buffer size. If a poll character is received (configurable from the Poll Character xx Hex option on the front panel from hex 0 through FF), the printer will send a response character *n* milliseconds later (configurable from the Poll Character xx MS on the front panel from 0 through 30). This *n* milliseconds is called the poll delay. The poll character will be removed from the input data stream and will not be processed. This may cause problems with the transmission of binary data (e.g., control codes, bit image, etc.). If a poll delay is started due to the receipt of a poll character and another poll character is received, the second poll character has no effect and is removed from the input data stream. If a transition (from buffer full to empty or online to offline) occurs during a poll delay, the new printer state will be sent at the end of the poll delay.

The response characters are described in Table 3.

Table 3. Series1 1 Char Response Characters

Printer State	Response
Online and Buffer Empty	CR
Online and Buffer Full	3
Offline and Buffer Empty	0
Offline and Buffer Full	2

- **SERIES1 2 CHAR.** This protocol behaves exactly the same as the Series1 Char except there is a two-character response to the host. The response characters are described in Table 4.

Table 4. Series1 2 Char Response Characters

Printer State	Response
Online and Buffer Empty	1 CR
Online and Buffer Full	3 CR
Offline and Buffer Empty	0 CR
Offline and Buffer Full	2 CR

- **DTR.** The printer controls the data flow by sending this hardware signal to the host. If there is enough room in the printer buffer, the printer will send a high signal; if the buffer is full, the printer will send a low signal. DTR tells the host if it is safe to send more data. (If the host sends data during an unsafe condition, data will be lost.) DTR is not available when RS-422 is selected.

Baud Rate

Sets the baud rate of the serial interface in the printer. Baud rate is the speed at which serial data is transferred between the host computer and the printer. The choices for the RS-232 and RS-422 interfaces are 600, 1200, 2400, 4800, 9600, 19200, 38400, 57600, and 115200 Baud. The default is 9600 Baud.

NOTE: If you select a baud rate that is greater than 19200, you may need to use RS-422 or select a lower baud rate to prevent data loss. You also may need to increase the Buffer Size in K parameter to improve performance.

Word Length

Sets the length of the serial data word. The length of the data word can be set to 7 or 8 bits, and must match the corresponding data bits setting in the host computer.

Stop Bits 1

Sets the number of stop bits in the serial data word. Either one or two stop bits can be selected. The setting must match the corresponding stop bit setting in the host computer.

Parity

Set for odd parity, even parity, mark, sense, or no parity. The setting must match the corresponding parity setting in the host computer.

Data Term Ready

This configuration is part of hardware flow control and determines when the Data Terminal Ready (DTR) signal is generated. This signal indicates if the printer is ready to receive data.

- **True** (default). Continuously asserts the DTR signal.
- **On Line and BNF (buffer not full)**. Asserts the DTR signal when the printer is online and the internal serial buffer is not full.
- **Off Line or BF (buffer full)**. Asserts the DTR signal when the printer is offline or the internal serial buffer is full.
- **On Line**. Asserts the DTR signal when the printer is online.
- **False**. Never asserts the DTR signal.

Request To Send

This configuration is part of hardware flow control and determines when the Request to Send (RTS) signal is generated. This signal indicates whether or not the printer is ready to receive data.

- **On Line and BNF** (default). Asserts the RTS signal when the printer is online and the internal serial buffer is not full.
- **Off Line or BF**. Asserts the RTS signal when the printer is offline or the internal serial buffer is full.
- **On Line**. Asserts the RTS signal when the printer is online.
- **False**. Never asserts the RTS signal.
- **True**. Continuously asserts the RTS signal.

Buffer Size in K

This option configures the amount of memory allocated for the serial port buffer. You may specify between 1 and 16 Kbytes, in 1-Kbyte increments.

NOTE: If you select a baud rate that is 19200 or greater, you may need to increase the Buffer Size in K parameter to improve performance.

Poll Character

This option is for the Series1 protocol. Whenever the printer receives this character, it sends a response to the host indicating the current state of the printer (see Series1 protocol). It may be configured from 0 through FF hexadecimal.

Poll Response

This option is for the Series1 protocol. After receiving a poll character, the printer will wait the poll response time in milliseconds before sending the response. It may be configured from 0 through 30.

Idle Response

This option is for the Series1 protocol.

- **Disable** (default)
- **Enable.** The printer will send a response character every two seconds while the number of valid bytes in the buffer is less than 75 percent of the buffer size.

One Char Enquiry

The One Char Enquiry mode uses the Poll Character to detect a request from the host and sends a response back to the host. This option also allows you to turn on and off this feature.

Table 5. One Char Enquiry Response Characters

Printer State	Response (hex)
Online and Buffer Not Full	22
Online and Buffer Full	23
Offline and Buffer Not Full	20
Offline and Buffer Full	21

The Poll Character is removed from the data stream. If the Data Protocol is set to ETX/ACK, ACK/NAK, or Series 1, One Char Enquiry is automatically disabled.

Framing Errors

Possible errors that can occur when the printer's serial interface settings do not match those of the host computer.

- **Enable** (default). If a framing error occurs, a fault message will display on the control panel.
- **Disable**. If a framing error occurs, a fault message will not display on the control panel.

E-Net Adapter Submenu

* = Factory Default

E-Net Adapter
(from page 85)

Buffer Size
in K

16*
1-16

The E-Net Adapter interface allows you to locate the printer on a LAN rather than attach the host directly into the printer. The detailed configuration of this option is given in the *PrintNet User's Manual*.

Buffer Size in K

This option configures the amount of memory allocated for the Ethernet buffer. You can specify between 1-16 Kbytes. The default is 16 Kbytes.

Ethernet Submenu

* = Factory Default



16*
1-16

The Ethernet interface allows you to locate the printer on a LAN rather than attach the host directly into the printer. The detailed configuration of this option is given in the *Network Interface Card User's Manual*.

Buffer Size in K

This option configures the amount of memory allocated for the Ethernet buffer. You can specify between 1 and 16 Kbytes, in 1-Kbyte increments. The default is 16 Kbytes.

NETWORK SETUP MENU

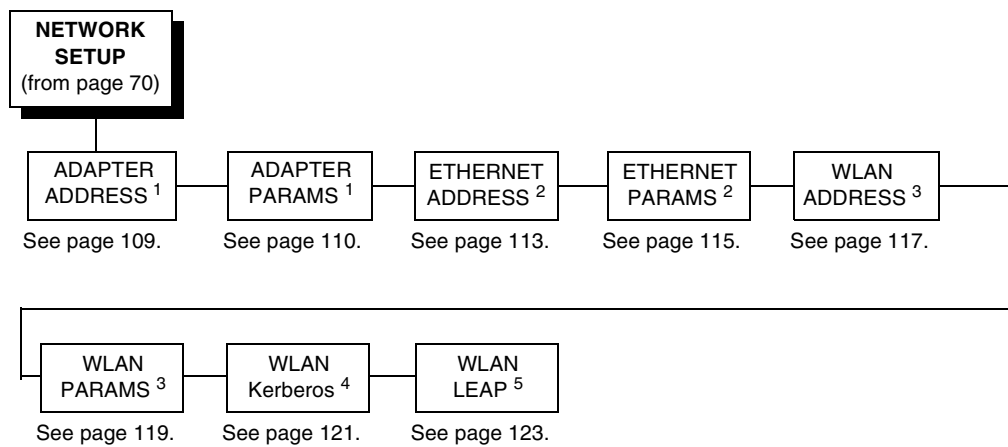

- ¹ Only if the Ethernet Adapter feature is installed.
- ² Only if the Integrated Ethernet feature is installed.
- ³ Only if the Wireless Adapter feature is installed.
- ⁴ Only if a Symbol radio card is installed.
- ⁵ Only if a Cisco radio card is installed.

ADAPTER ADDRESS

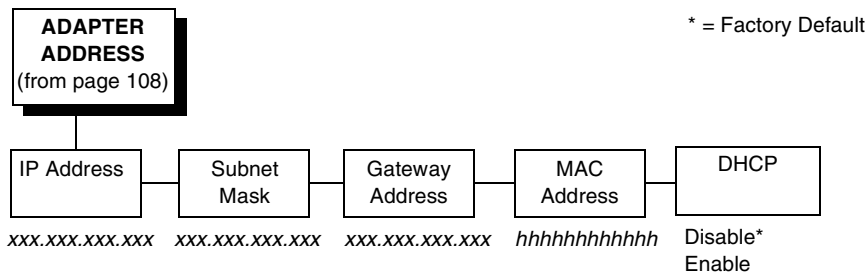

IP Address

A numeric address such as 123.45.61.23 which identifies a printer or server in a LAN or WAN.

Subnet Mask

A binary value used to divide IP networks into smaller subnetworks or subnets. This mask is used to help determine whether IP packets need to be forwarded to other subnets.

Gateway Address

A gateway address is the IP address of a hardware device (gateway) that translates data between two incompatible networks, which can include protocol translation.

MAC Address

This menu item is the Manufacturer's Assigned Number, and is unique for each printer. It is read-only.

Chapter 4 NETWORK SETUP MENU

DHCP

You can enable/disable the DHCP protocol using this option, but consult your administrator for the appropriate setting.

The options include:

- **Disable** (default)
- **Enable**.

ADAPTER PARAMS

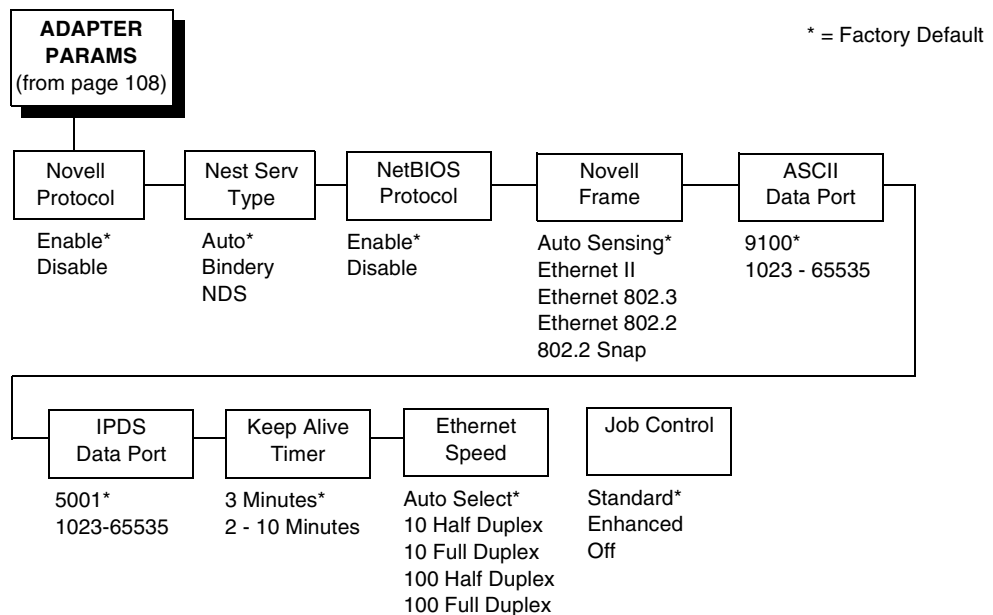

You may enable or disable the Novell or NetBIOS Protocols within this menu, as well as selecting which Novell Frame scheme to use in processing Novell signals. See the Novell chapter in the *Network Interface Card User's Manual* for more details.

Novell Protocol

This option determines whether the Novell protocol will be available. The selections are as indicated below:

- **Enable** (default). Makes the Novell protocol available with the ethernet installed.
- **Disable**. Makes the Novell protocol unavailable during printer operation.

Nest Serv Type

You can change the Nest Server using this option, but consult your administrator for the appropriate setting.

The options are Bindery (the factory default), NDS, and Auto.

NetBIOS Protocol

This option determines whether the NetBIOS protocol will be available. The selections are as indicated below:

- **Enable** (default). Makes the NetBIOS protocol available with the ethernet installed.
- **Disable**. Makes the NetBIOS protocol unavailable during printer operation.

Novell Frame

This selection determines which framing scheme will be used in processing Novell signals.

- **Auto Sensing** (default)
- **Ethernet II**
- **Ethernet 802.3**
- **Ethernet 802.2**
- **802.2 Snap**

ASCII Data Port

This option sets the port number for ASCII print jobs. The data port number needs to match your host system setting.

- **9100** (default)
- **1023 - 65535**

IPDS Data Port

This option allows you to set the port number for IPDS print jobs only if the IPDS option is installed.

The range is 0 - 5000, and the factory default is 5001.

Keep Alive Timer

This is the time that the Keep Alive Timer will run. With the Keep Alive Timer on, the tcp connection will stay connected even after the print job has terminated.

- **3 Minutes** (default)
- **2 - 10 Minutes**

Ethernet Speed

This menu option only appears if a 10/100Base-T network interface card (NIC) is installed. The Ethernet Speed menu allows compatibility with different systems and networks. The factory default is Auto Select.

- **Auto Select.** (default) This setting tells the 10/100Base-T NIC to perform an auto detection scheme and configure itself to be 10 Half Duplex, 10 Full Duplex, 100 Half Duplex, or 100 Full Duplex.
- **10 Half Duplex.** Tells the 10/100Base-T NIC to communicate at 10 Megabits per second using half duplex.
- **10 Full Duplex.** Tells the 10/100Base-T NIC to communicate at 10 Megabits per second using full duplex.

ETHERNET ADDRESS

- **100 Half Duplex.** Tells the 10/100Base-T NIC to communicate at 100 Megabits per second using half duplex.
- **100 Full Duplex.** Tells the 10/100Base-T NIC to communicate at 100 Megabits per second using full duplex.

Job Control

The job control mode has three options:

- **Standard** (default). The NIC waits for the printer to finish receiving the current job before sending another job. The status line shows “done” when the job is completely received by the NIC. This is the default.
- **Enhanced.** The NIC waits for the printer to finish receiving the current job before sending another job. The status line shows “done” when the job is fully printed.
- **Off.** No job synchronization between the NIC and the printer.

ETHERNET ADDRESS

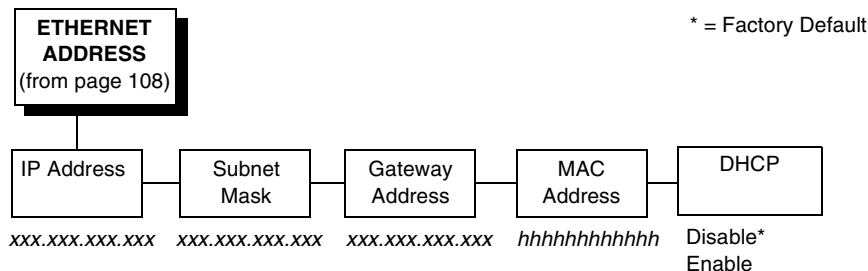

IP Address

A numeric address such as 123.45.61.23 which identifies a printer or server in a LAN or WAN.

Subnet Mask

A binary value used to divide IP networks into smaller subnetworks or subnets. This mask is used to help determine whether IP packets need to be forwarded to other subnets.

Gateway Address

A gateway address is the IP address of a hardware device (gateway) that translates data between two incompatible networks, which can include protocol translation.

MAC Address

This menu item is the Manufacturer's Assigned Number, and is unique for each printer. It is read-only.

DHCP

You can enable/disable the DHCP protocol using this option, but consult your administrator for the appropriate setting.

The options include:

- **Disable** (default)
- **Enable**.

ETHERNET PARAMS

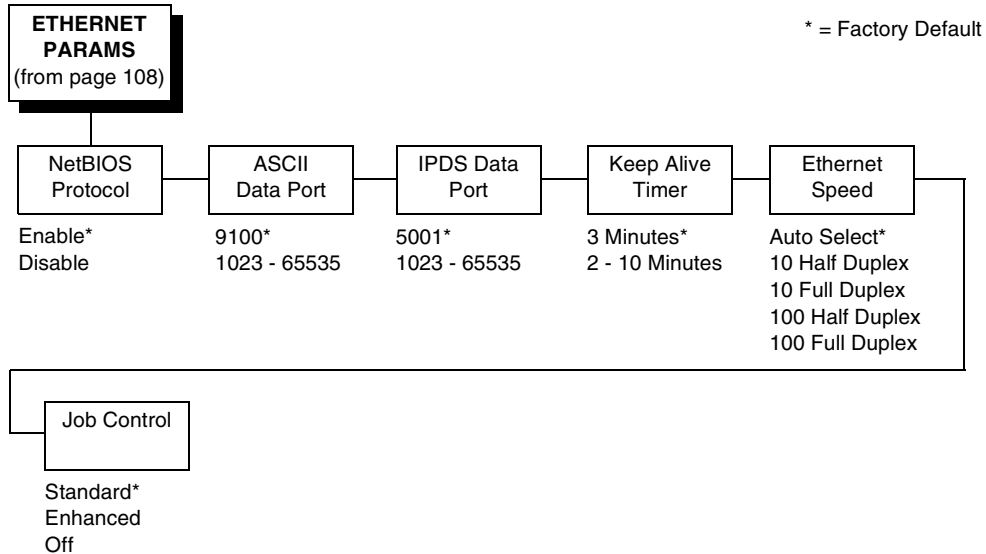

The ETHERNET PARAMS menu helps your printer communicate on a network.

For information on assigning the IP Address, Gateway Address, Subnet Mask, and MAC Address, refer to the *Network Interface Card User's Manual*.

NetBIOS Protocol

This option determines whether the NetBIOS protocol will be available. The selections are as indicated below:

- **Enable** (default). Makes the NetBIOS protocol available with the ethernet installed.
- **Disable**. Makes the NetBIOS protocol unavailable during printer operation.

ASCII Data Port

This option sets the port number for ASCII print jobs. The data port number needs to match your host system setting.

- **9100** (default)
- **1023 - 65535**

IPDS Data Port

This option allows you to set the port number for IPDS print jobs only if the IPDS option is installed.

The range is 1023 - 65535, and the factory default is 5001.

Keep Alive Timer

This is the time that the Keep Alive Timer will run. With the Keep Alive Timer on, the tcp connection will stay connected even after the print job has terminated.

- **3 Minutes** (default)
- **2 - 10 Minutes**

Ethernet Speed

This menu option only appears if a 10/100Base-T network interface card (NIC) is installed. The Ethernet Speed menu allows compatibility with different systems and networks. The factory default is Auto Select.

- **Auto Select.** (default) This setting tells the 10/100Base-T NIC to perform an auto detection scheme and configure itself to be 10 Half Duplex, 10 Full Duplex, 100 Half Duplex, or 100 Full Duplex.
- **10 Half Duplex.** Tells the 10/100Base-T NIC to communicate at 10 Megabits per second using half duplex.
- **10 Full Duplex.** Tells the 10/100Base-T NIC to communicate at 10 Megabits per second using full duplex.

WLAN ADDRESS

- **100 Half Duplex.** Tells the 10/100Base-T NIC to communicate at 100 Megabits per second using half duplex.
- **100 Full Duplex.** Tells the 10/100Base-T NIC to communicate at 100 Megabits per second using full duplex.

Job Control

The job control mode has three options:

- **Standard** (default). The NIC waits for the printer to finish receiving the current job before sending another job. The status line shows “done” when the job is completely received by the NIC. This is the default.
- **Enhanced.** The NIC waits for the printer to finish receiving the current job before sending another job. The status line shows “done” when the job is fully printed.
- **Off.** No job synchronization between the NIC and the printer.

WLAN ADDRESS

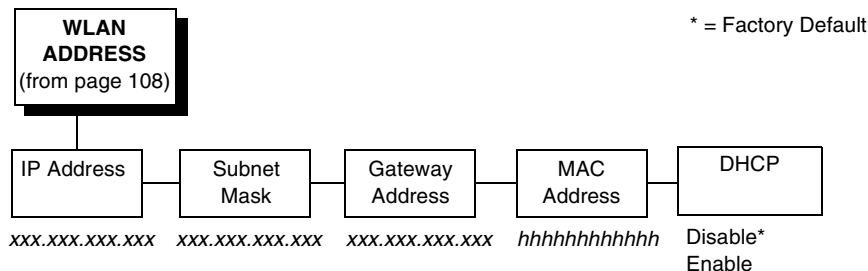

IP Address

A numeric address such as 123.45.61.23 which identifies a printer or server in a LAN or WAN.

Subnet Mask

A binary value used to divide IP networks into smaller subnetworks or subnets. This mask is used to help determine whether IP packets need to be forwarded to other subnets.

Gateway Address

A gateway address is the IP address of a hardware device (gateway) that translates data between two incompatible networks, which can include protocol translation.

MAC Address

This menu item is the Manufacturer's Assigned Number, and is unique for each printer. It is read-only.

DHCP

You can enable/disable the DHCP protocol using this option, but consult your administrator for the appropriate setting.

The options include:

- **Disable** (default)
- **Enable**.

WLAN PARAMS

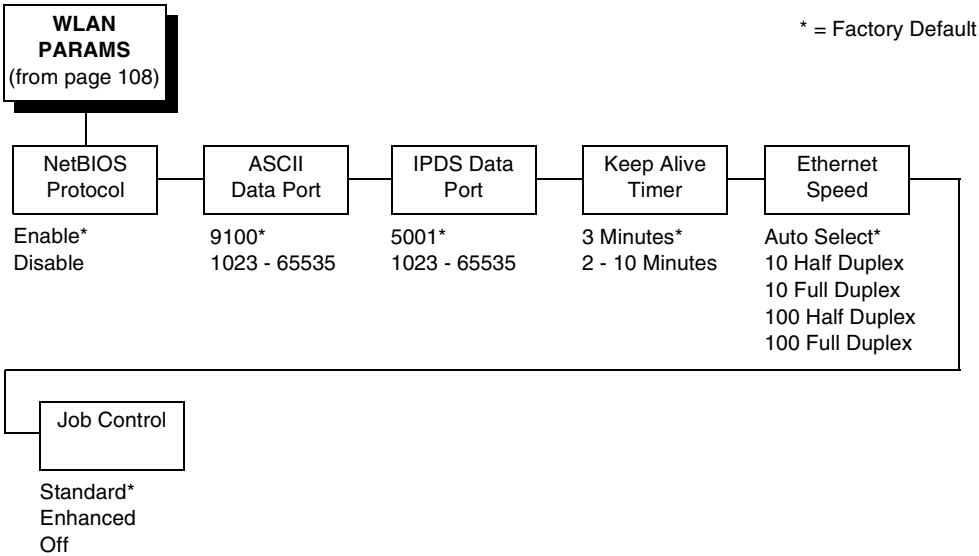

For information on assigning the IP Address, Gateway Address, Subnet Mask, and MAC Address, refer to the *Network Interface Card User's Manual*.

NetBIOS Protocol

This option determines whether the NetBIOS protocol will be available. The selections are as indicated below:

- **Enable** (default). Makes the NetBIOS protocol available with the ethernet installed.
- **Disable**. Makes the NetBIOS protocol unavailable during printer operation.

ASCII Data Port

This option sets the port number for ASCII print jobs. The data port number needs to match your host system setting.

- **9100** (default)
- **1023 - 65535**

IPDS Data Port

This option allows you to set the port number for IPDS print jobs only if the IPDS option is installed.

The range is 1023 - 65535, and the factory default is 5001.

Keep Alive Timer

This is the time that the Keep Alive Timer will run. With the Keep Alive Timer on, the tcp connection will stay connected even after the print job has terminated.

- **3 Minutes** (default)
- **2 - 10 Minutes**

WLAN KERBEROS

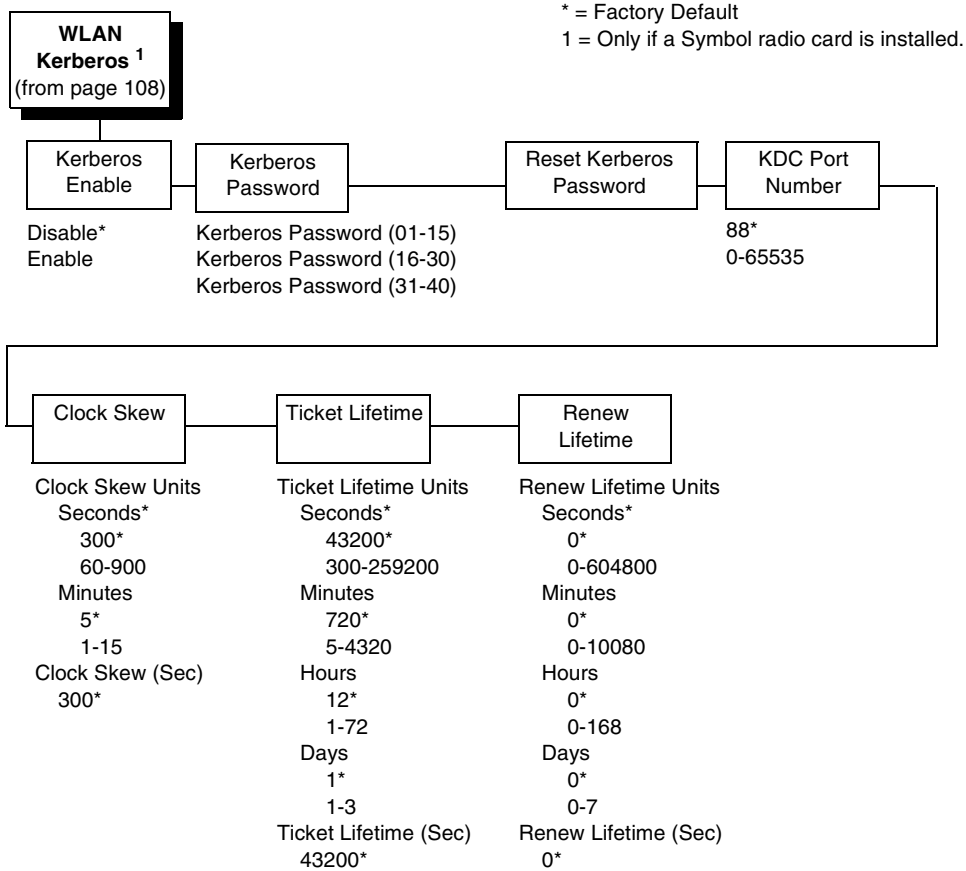

Kerberos Enable

- **Disable** (the default). Disables Kerberos authentication in the wireless network interface.
- **Enable**. Enables Kerberos authentication in the wireless network interface.

Kerberos Password

- **Kerberos Password (01-15).** The first 15 characters of the Kerberos password (maximum number of characters is 40).
- **Kerberos Password (16-30).** Characters 16 to 30 of the Kerberos password (maximum number of characters is 40).
- **Kerberos Password (31-40).** Characters 31 to 40 of the Kerberos password (maximum number of characters is 40).

Reset Kerberos Password

Resets the Kerberos password to an empty string.

KDC Port Number

KDC (Key Distribution Center) port number is the 2-byte UDP/TCP port used for Kerberos Communication.

The range is 0-65535, and the factory default is 88.

Clock Skew

Sets the maximum allowable amount of time in seconds or minutes that Kerberos authentication will tolerate before assuming that a Kerberos message is valid. The range for Seconds is 60-900, and the default is 300. The range for Minutes is 1-15, and the default is 5.

Ticket Lifetime

Sets the maximum allowable amount of time in Seconds, Minutes, Hours, or Days that a ticket obtained from the Kerberos server is valid before getting a new one.

- **Seconds.** The range is 300-259200, and the default is 43200.
- **Minutes.** The range is 5-4320, and the default is 720.
- **Hours.** The range is 1-72, and the default is 12.
- **Days.** The range is 1-3, and the default is 1.
- **Ticket Lifetime (Sec).** The ticket lifetime unit in seconds. The default is 43200.

Renew Lifetime

Sets the maximum allowable amount of time in Seconds, Minutes, Hours, or Days before warning that a new Kerberos password is needed.

- **Seconds.** The range is 0-604800, and the default is 0.
- **Minutes.** The range is 0-10080, and the default is 0.
- **Hours.** The range is 1-168, and the default is 0.
- **Days.** The range is 0-7, and the default is 0.
- **Renew Lifetime Units.** Renew lifetime unit in seconds. The default is 0.

WLAN LEAP

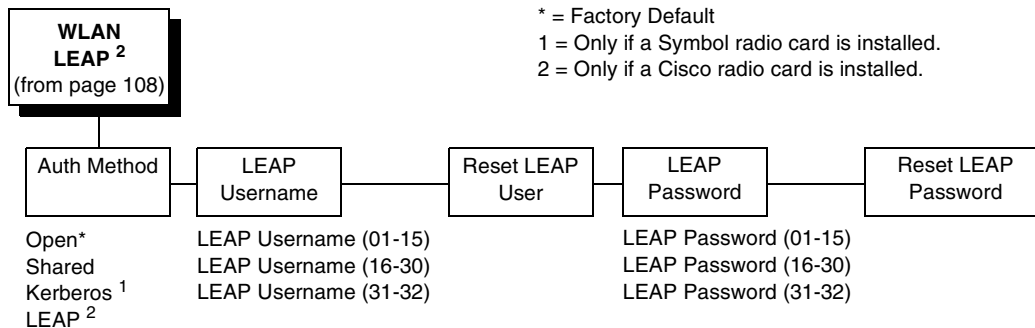

Auth Method

This feature allows the user to select the authentication method used for the wireless network interface.

- **Open** (the default). Selects open authentication.
- **Shared.** Selects shared key authentication.
- **Kerberos.** Selects Kerberos authentication (for use when a Symbol RF card is installed).
- **LEAP.** Selects LEAP authentication (for use with a Cisco RF card installed).

LEAP Username

- **LEAP Username (01-15)**. The first 15 characters of the LEAP user name (maximum number of characters is 32).
- **LEAP Username (16-30)**. Characters 16 to 30 of the LEAP user name (maximum number of characters is 32).
- **LEAP User (31-32)**. Characters 31 to 32 of the LEAP user name (maximum number of characters is 32).

Reset LEAP User

Resets the LEAP user name to an empty string.

LEAP Password

- **LEAP Password (01-15)**. The first 15 characters of the LEAP password (maximum number of characters is 32).
- **LEAP Password (16-30)**. Characters 16 to 30 of the LEAP password (maximum number of characters is 32).
- **LEAP Password (31-32)**. Characters 31 to 32 of the LEAP password (maximum number of characters is 32).

Reset LEAP Password

Resets the LEAP password to an empty string.

ACTIVE (IGP) EMUL

* = Factory Default

**ACTIVE (IGP)
EMUL**
(from page 70)

IGP/PGL*
IGP/VGL
(not shown if any
below are installed)
ANSI (if installed)
PCL-II (if installed)
LG (if installed)
LP+ (with any above)

This ACTIVE (IGP) EMUL function allows you to activate the desired emulation. There are two methods for selecting the desired emulation. The first is by selecting the emulation directly from the printer menu. The second is by sending a host command which will switch the emulation automatically (see the appropriate Programmer's Reference Manual for details).

When changing from one emulation to the other, the printer will load the power-up configuration and the new emulation parameters. Any configuration settings performed before selecting these emulations that are not saved in NVRAM will be lost.

IMPORTANT

To configure an IGP emulation, the IGP emulation must be selected in the ACTIVE (IGP) EMUL menu. The IGP emulation that is not selected will not appear in the EMULATION menu (see "Main Menu" on page 70).

IGP/PGL Emulation

The PGL emulation is the software based Intelligent Graphics Processor (IGP) for the line matrix family of printers. It is based upon, and is compatible with, the IGP-100/200/400 board using the PGL. The IGP graphics processing features are detailed below.

Features

On-Line Form and Label Generation makes it easy to create forms or labels with a “preprinted” look for each application. IGP programs control all graphic functions, dramatically reducing host computer programming and processing time.

Graphic capabilities include boxes, vertical and horizontal lines with user-selectable thickness, logos, and special alphanumeric print features. Forms and graphic designs can be duplicated horizontally and vertically.

Alphanumeric data can appear as prepositioned “fixed” information (entered when the form is created), be overlaid onto the form (positioned in a specific location after the form is created), or can be dynamically merged with the form.

Selectable Barcodes provide you with the appropriate barcode for your application using standard wide-to-narrow ratios. A wide selection of barcodes is available: Code 39, Interleaved 2 of 5, UPC-A, UPC-E, MSI A through D, Code 128 Subset A, B, and C, EAN/UCC-128, EAN 8, EAN 13, POSTNET, PostBar, Royal Mail, and PDF417. UPC and EAN barcodes can specify add-on data.

Expanded and Compressed Character Print attract attention where needed. Alphanumeric height and width are controlled independently for a wide range of character sizes up to 113 times the standard character size (up to 11.3 inches wide and tall). Compressed print sizes of 10, 12, 13, 15, 17, and 20 characters per inch (cpi) are available.

Logos are created using alphanumeric commands and add many print and shading features for a “customized” appearance to forms, reports, and labels.

Rotated Alphanumerics permit new concepts in form design. Normal, expanded, and compressed character strings can be rotated 90 degrees clockwise or counterclockwise, or they can be printed upside down.

Reversed Print permits highlighting and contrasting by printing white characters on a dark background.

Automatic Increment/Decrement Capability allows batch form processing. Individual alphabetic, numeric, and barcode data fields can be identified and automatically incremented or decremented by any amount, beginning from a specified reference point.

Scaling Capability permits graphic elements, such as corners or boxes, to retain their physical shapes and sizes when printed in a horizontal and vertical density other than the base density of 60 x 72 dpi.

Multinational Character Sets provide many international character sets, each 96 characters in length. This feature also allows you to create your own character sets using characters defined and stored in memory.

Extended Character Sets provide 33 extended character sets, also containing 96 characters in length. These are also stored in memory.

Configuring The Emulation With The Control Panel

You can select PGL default parameters directly from the control panel or by control codes as explained in the *IGP/PGL Programmer's Reference Manual*. The PGL parameters are described on the following pages. Parameters marked with an asterisk (*) indicate the default value. The printer must be offline to enter the configuration structure.

Pressing an invalid key to enter a parameter value may move you to another level in the configuration or exit the configuration menu completely. Configure the IGP/PGL according to your specific requirements.

IMPORTANT **BEFORE you reconfigure the IGP/PGL, print a configuration sheet to see all of the current settings.**

IGP/PGL Submenu

* = Factory Default

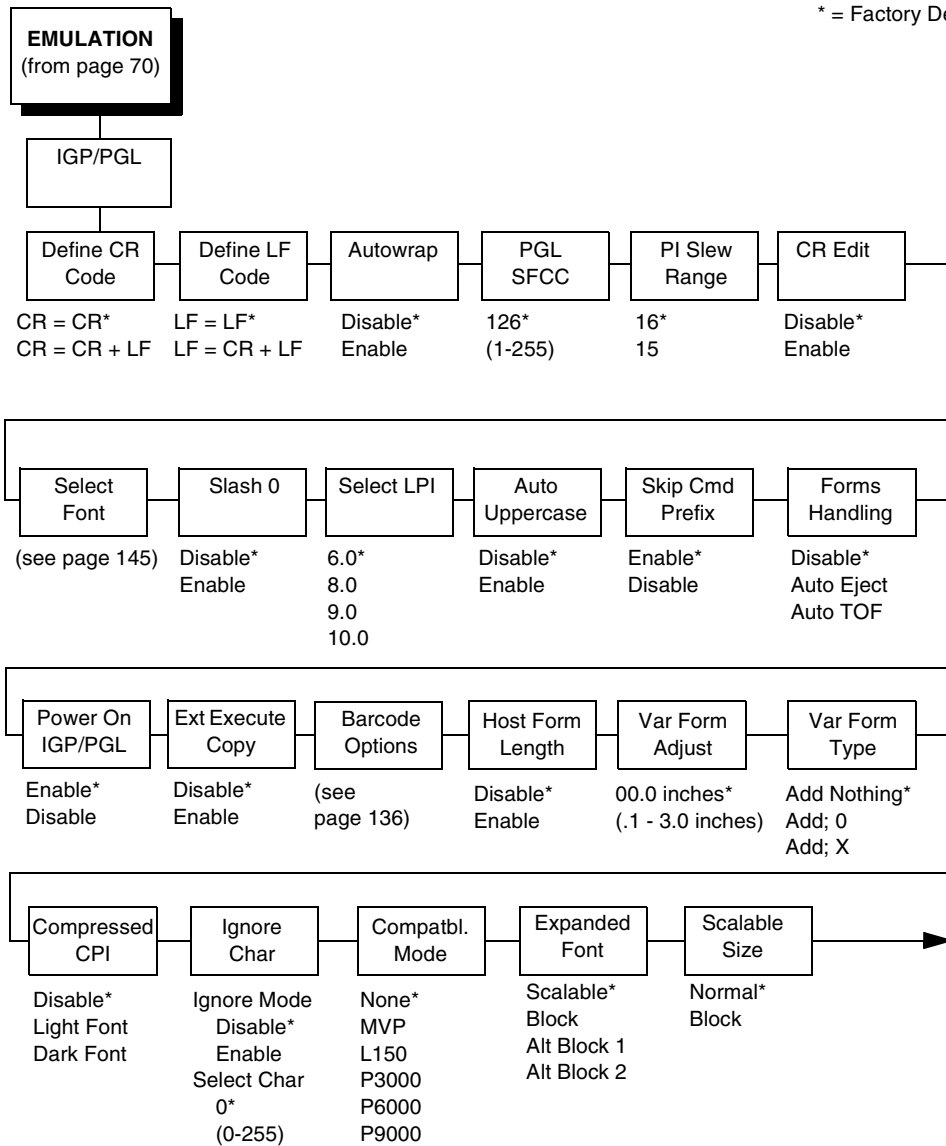

Chapter 4 IGP/PGL Emulation

* = Factory Default

IGP/PGL
(Continued)

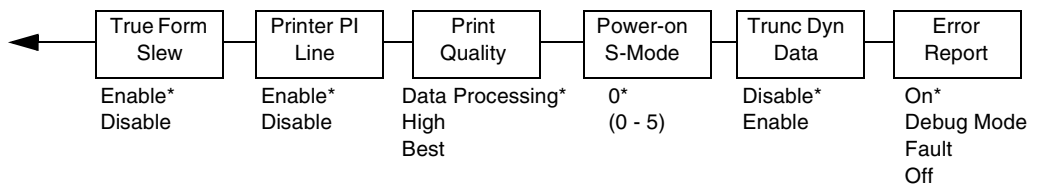

IGP/PGL Submenu (with PCL-II)

IGP/PGL Submenu (with PCL-II)

* = Factory Default

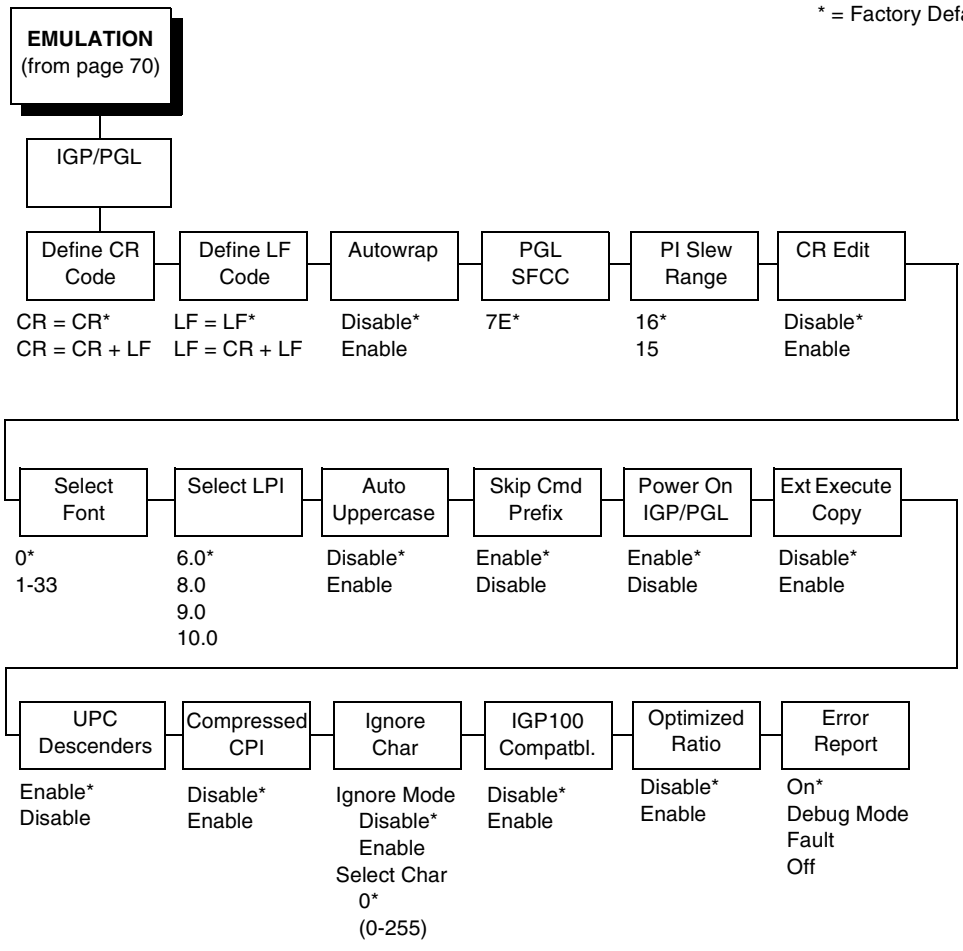

Chapter 4 IGP/PGL Emulation

IGP/PGL Submenu (with LG)

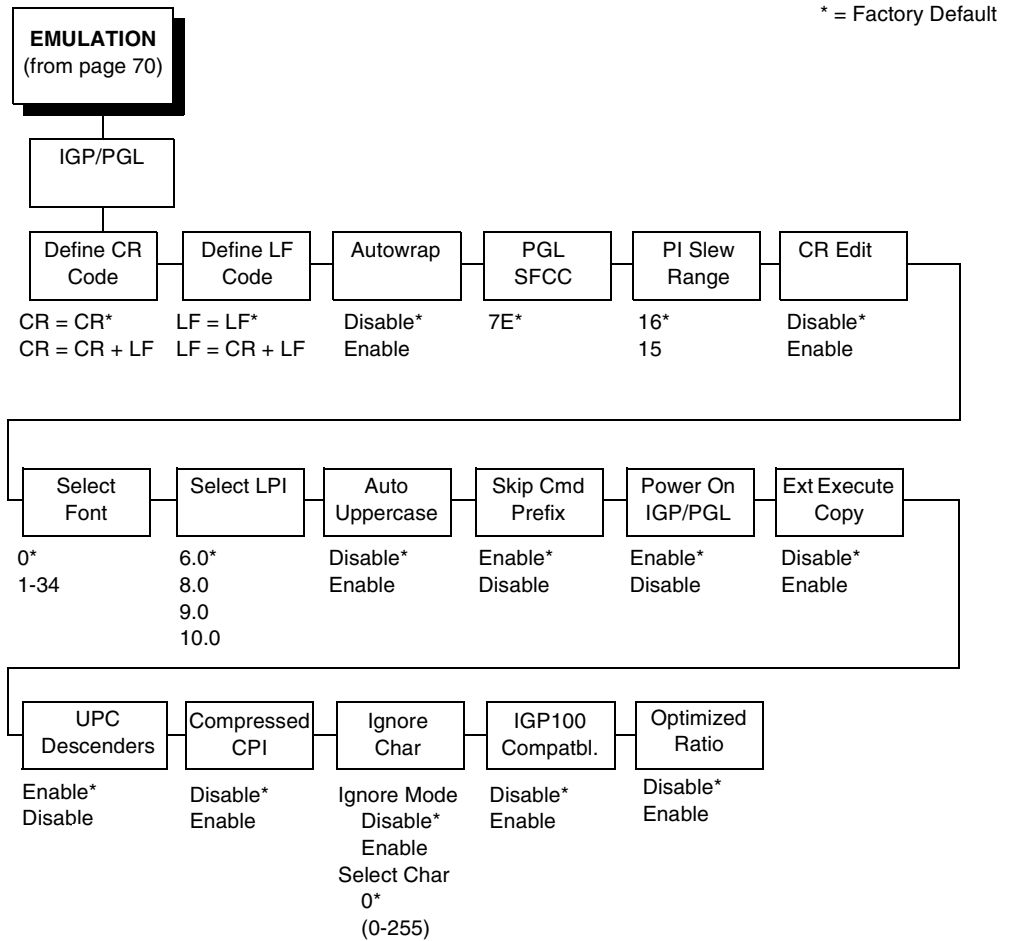

Define CR (Carriage Return) Code

This parameter forces the printer to insert an automatic Line Feed code into the data stream whenever a Carriage Return code occurs. This is to be used only if the host computer does not send line feeds to the printer.

- **CR = CR** (default). Does not perform a line feed. The next print position will be print position 1 of the current line.
- **CR = CR + LF**. Performs an automatic line feed. The next print position will be print position 1 of the next line.

Define LF (Line Feed) Code

This parameter forces the printer to insert an automatic Carriage Return code into the data stream whenever a Line Feed code occurs. This can be used in most installations, but it is required if the host computer does not send carriage returns to the printer.

- **LF = LF** (default). Does not perform an automatic carriage return. The next print position will be the current print position of the next line.
- **LF = CR + LF**. Performs an automatic carriage return. The next print position will be print position 1 of the next line.

Autowrap

This parameter determines if text will wrap to the next line when the line of text exceeds the right margin.

- **Disable** (default). Truncates the text beyond the right margin until a CR or CR + LF is received.
- **Enable**. Automatically inserts a CR + LF after a full print line.

PGL SFCC

You can specify which hex code (1-255) will be used as the Special Function Control Code (SFCC). The factory default setting is 126. The SFCC denotes that the following data is a PGL command.

PI Slew Range

You can specify how many lines the paper will feed.

- **15.** A paper slew of 1-15 will move 1-15 lines. A paper slew of 0 will move 1 line.
- **16.** A paper slew of 0-15 will move 1-16 lines.

CR Edit

This parameter determines if a carriage return will be followed by a line feed.

- **Disable** (default). The printer ignores all carriage returns that are not followed by line feeds.
- **Enable.** The printer processes all carriage returns, even for those that are not followed by line feeds.

Select Font

Select Font specifies which language is currently selected for use with the PGL. Refer to “IGP/PGL Font Set Menu” on page 145 for available selections.

Slash 0

This parameter allows you to print the numeral “0” with or without the slash. This option applies to all character sets except OCR A and OCR B.

- **Disable** (default). Zero is printed without a slash.
- **Enable.** Zero is printed with a slash.

Select LPI

This is the number of lines to be printed per inch. For example, at 6 lpi there is 1/6 inch from the top of one print line to the top of the next print line. The options are:

- **6.0** (default)
- **8.0**
- **9.0**
- **10.0**

Auto Uppercase

This parameter enables the printer to print text in all uppercase when using the ALPHA command.

- **Disable** (default). The printer will print text in upper and lowercase.
- **Enable**. The printer will print text in uppercase only.

Skip Cmd Prefix

This parameter determines if the printer will print any data before a PGL command is received.

- **Enable** (default). The printer ignores all data on the current line before an IGP command.
- **Disable**. The printer will print all data on the current line before an IGP command.

Forms Handling

This submenu allows the user to handle the form in the following ways:

- **Disable** (the default). No effect.
- **Auto Eject**. Automatically ejects a page at the end of the job to spill out the last page.
- **Auto TOF**. Automatically does a form feed (FF) at the end of each form to the next top of form.

Power On IGP/PGL

You can set the IGP feature so that it is enabled or disabled when the printer is powered on.

- **Enable** (default). The PGL is enabled when the printer is powered on. (The PGL feature is initialized in the Normal mode.)
- **Disable**. The PGL is disabled when the printer is powered on. (The PGL feature is initialized to the Quiet mode.)

Ext Execute Copy

- **Disable** (default). Dynamic data and overlay data are not allowed if the optional Form Count parameter (number of forms to print) is specified as part of the Execute command. (This setting is IGP-100 compatible.)
- **Enable**. Only dynamic data is allowed within a form in which the Form Count parameter is specified in the Execute command. In this case, the exact same form (with identical dynamic data, etc.) is printed for the Form Count. However, incremental data is not incremented since the page that is printing is exactly the same. Also, each form is printed on a separate page.

* = Factory Default

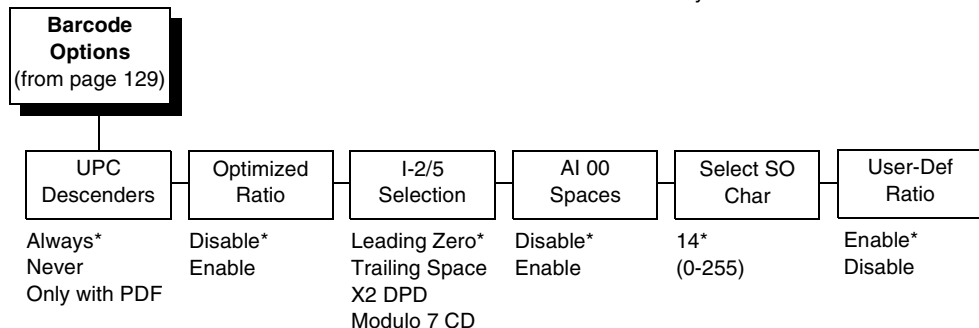

Barcode Options

The following sub-options help define specific options regarding barcode printing.

UPC Descenders

This parameter allows you to print barcode descenders when human readable data is not present in the UPC/EAN barcodes.

- **Always** (default). UPC/EAN barcodes are printed with descenders, even if there is no human readable data.
- **Never**. UPC/EAN barcodes are printed without descenders if there is no human readable data.
- **Only with PDF**. UPC/EAN barcodes are printed with descenders only when the PDF command is present.

Optimized Ratio

This option selects different barcode ratios for certain barcodes including Code 39 and I-2/5. It is included for compatibility with the IGP-X00 printers.

- **Disable** (default). Use standard barcode ratios.
- **Enable**. Select the alternate barcode ratios.

I-2/5 Selection

This option is added to be compatible with a special IGP-X00 customization. Usually, if I-2/5 barcodes have an odd number of digits, a leading zero is inserted in front of the data. However, this special IGP-X00 customization gives you the option of adding a space character at the end of the barcode instead.

- **Leading Zero** (default). A leading zero is inserted in front of the data.
- **Trailing Space**. A space is inserted at the end of the data.
- **X2 DPD**. When selected, an I-2/5 barcode with an X2 magnification will use the specially configured ratios 3:3:6:5 rather than 3:6:9:12 for compatibility issues.
- **Modulo 7 CD**. The I-2/5 barcode uses a modulo 7 check digit instead of the default modulo 10 check digit.

AI 00 Spaces

This option is designated for EAN/UCC-128 barcodes whose application identifier (AI) is 00.

- **Disable** (default). The printable data field is printed with the AI enclosed in parentheses. This is the standard EAN/UCC-128 format.
- **Enable**. The printable data field is printed with the UCC fields separated by spaces. This option is IGP-X00 compatible.

Select SO Char

Allows you to specify a decimal code from 0 through 255 to be used in place of SO (Shift Out) as the control code. This allows access for the alternate set of control function characters. See the description of the Code 128 barcodes in the *IGP/PGL Programmer's Reference Manual* for details.

User-Def Ratio

- **Enable** (default). User-defined ratios are accepted for barcodes. This is the default.
- **Disable**. User-defined ratios are ignored and the magnification X1 is used in its place.

Host Form Length

Determines whether the form length specified in the CREATE command changes the form length designated in the LP+ menu (see “LinePrinter Plus Emulation” on page 209) when the form is printed by the EXECUTE command.

- **Disable** (default). The LP+ form length is unaffected by the form being printed.
- **Enable**. The LP+ form length changes to match the length of the PGL form being printed.

Var Form Adjust

(Ranges from 0 - 30). Default is 0. This menu value is tenths of inches. The value of this menu specifies the amount of distance to add to PGL forms that have variable form lengths. Variable length forms are forms that are defined by using a “;0” in the CREATE statement: ~CREATE;FORM;0. Variable form lengths are defined by the contents within the form - the form is only as long as necessary to print the form. Changing this menu value adds additional lengths to the form (in tenths of inches). Again, this only applies to forms that use the “;0” variable length forms.

Var Form Type

This menu option applies only to the host command, CREATE;NAME or CREATE;NAME;DISK. The option also applies to the host command CREATE;NAME followed by ;0, ;X or a form length number that always overrides the menu option.

- **Add Nothing** (default). No action.
- **Add; 0**. When selected, the form length ends at the longest printed element. Same as CREATE;NAME;0.
- **Add; X**. When selected, the form length is the same as the physical page length.

Compressed CPI

This parameter allows you to choose a compressed character (60% shorter) for 17 or 20 cpi instead of the normal height character.

- **Disable**(default). The PGL does not use compressed 17 or 20 cpi font.
- **Light Font**. Uses the standard compressed 17 or 20 cpi font.
- **Dark Font**. Uses a darker compressed 17 or 20 cpi font compatible with the IGP-X00 printers.

Ignore Char

Ignore Mode

This parameter instructs the PGL to ignore the character selected under the Select Character menu.

- **Disable** (default). The PGL does not ignore any characters.
- **Enable**. The PGL ignores the characters specified in the Select Character menu.

Select Char

Instructs the PGL which decimal character (0-255) to ignore from the host.

Compatbl. Mode

This option instructs the PGL to behave similarly to older versions of the IGP with respect to certain commands.

All new users with new applications should select the “None” option. Selecting this mode insures the printer will behave as described in this manual.

When replacing an older product operating with an existing application, especially those using the PMODE and SMODE commands, you may need to select a compatibility mode. In this case, select the printer model number option that most closely matches the printer being replaced. The Compatibility Mode options include:

- **None** (default)
- **MVP**
- **L150**
- **P3000**
- **P6000**
- **P9000**

Expanded Font

This option defines the type of expanded characters the PGL will select:

- **Scalable** (default). These expanded characters have rounded edges.
- **Block**. These are block characters compatible with the IGP-X00 printers.
- **Alt Block 1 / Alt Block 2**. Reserved block sets used only for compatibility purposes.

Scalable Size

- **Normal** (default). Controls the size of scalable characters to be either normal size (as set by the user) or adjusted to match the size of block fonts. This is the default.
- **Block**. Adjusts the size of scalable characters to exactly match its block font alternative.

True Form Slew

This option is related to slewing within forms when using the PMODE command. Customers with new applications are advised to keep this option enabled.

- **Enable** (default). Form length is accurate according to the form length parameter in the CREATE command.
- **Disable**. Form length is IGP-X00 compatible when using PMODE.

Printer PI Line

This option enables the IGP to send PI instructions to the printer to slew the form.

- **Enable** (default). Send the PI instructions to the printer (LinePrinter Plus) during form slew. This is IGP-X00 compatible.
- **Disable**. Do not send PI instructions to the printer. LFs are sent instead.

Print Quality

- **Data Processing** (default). The emulation prints at 60 x 72 dpi and lets you choose between normal alphanumerics and barcodes and dark mode alphanumerics and barcodes. This mode should be set if you want the highest speed.
- **High**. The emulation prints at 120 x 72 dpi, but all alphanumerics and barcodes are automatically printed in dark mode.
- **Best**. The emulation prints at 120 x 144 dpi and dark mode, which produces a higher resolution, better-looking print image.

Power-on S-Mode

This option instructs the PGL to behave similarly to older versions of the IGP with respect to certain commands.

All new users with new applications should select "0," the default option. Selecting this mode insures the printer will behave as described in this manual.

Power on S-Mode sets the printer in an SMODE compatibility state at power-up. The default is 0 (disabled, no power-on mode). To use this feature, select a mode from 1 through 5, which puts IGP/PGL in an SMODE state according to the compatibility mode set. If the compatibility mode set is None, then MVP is assumed by default.

For more information, see the *IGP/PGL Programmer's Reference Manual*.

Trunc Dyn Data

This submenu allows the user to truncate the dynamic data up to the maximum data length specified in Create Mode.

- **Disable** (the default). If the dynamic data exceeds the maximum data length, an error will report.
- **Enable**. If the dynamic data exceeds the maximum data length, the data truncates.

Error Report

Sets the error reporting capability for IGP/PGL forms.

- **On** (default). Form boundary error checking reported. Any element which falls off the current page is reported as an error.
- **Debug Mode**. The printer is put in debug mode whenever a form is defined in Create Form mode. Each line of the Create Form is printed along with an error if one occurred. This is the same functionality as if there were a slash (/) entered before the Create Form Name.
- **Fault**. When an error occurs, the error is printed and the message "IGP/PGL ERROR" appears on the printer front panel. The printer then stops printing and goes offline. The error must be cleared before the printer can resume normal operation.
- **Off**. No form boundary checking. Graphic elements appear clipped if they are beyond the page boundaries.

IGP/PGL Font Set Menu

Select Font
(see page 129)

* = Factory Default

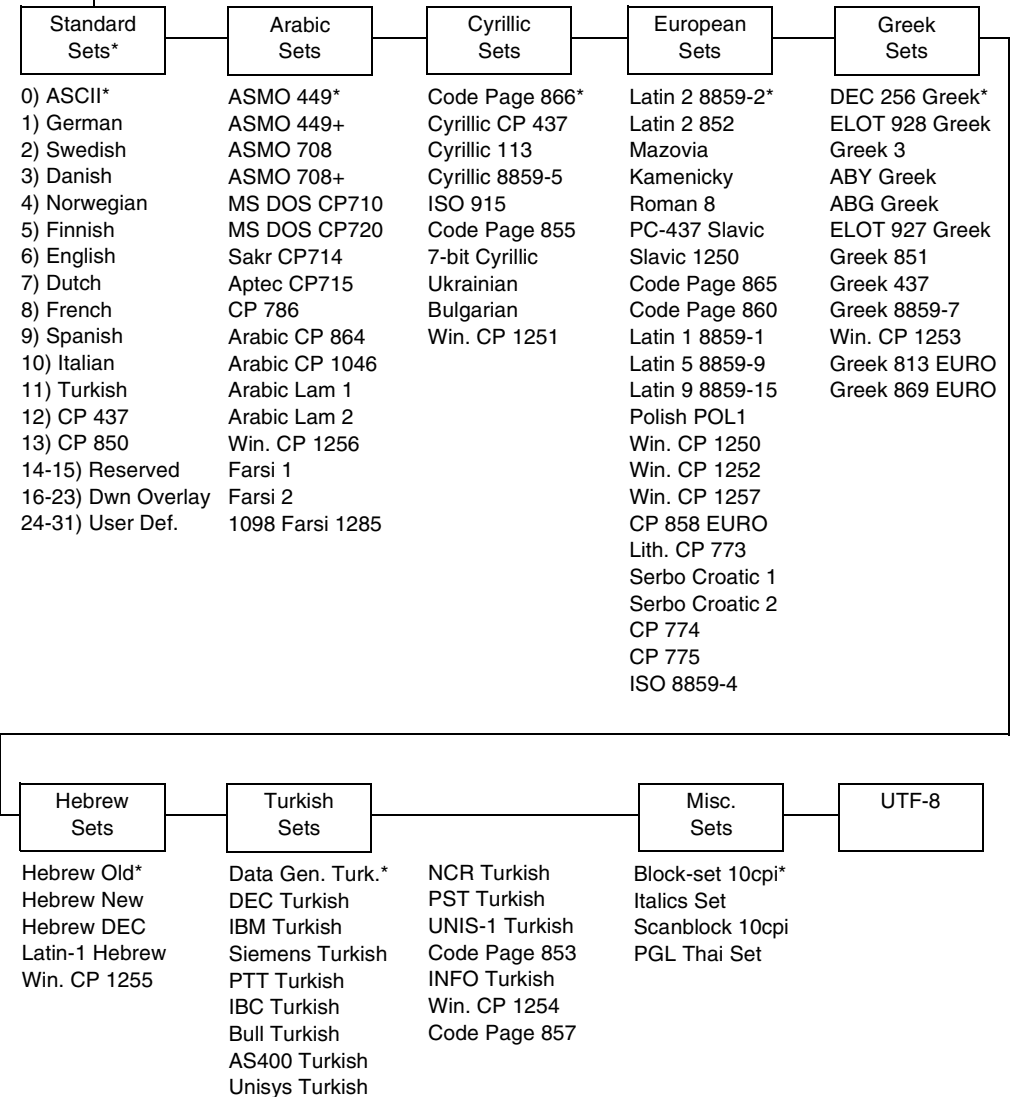

IGP/VGL Emulation

Code V Graphics language (VGL) is an Intelligent Graphics Printing (IGP) software emulation designed for your Line Matrix printer. The IGP Code V emulation of the QMS[®] Code V Version II programming language produces online forms, barcodes, and alphanumeric text-generation. The graphics processing features are detailed below.

Features

OnLine Form and Label Generation makes it easy to create forms or labels with the “preprinted” look for each application. VGL programs control all graphics functions, dramatically reducing host computer programming and processing time. Graphics capabilities include boxes, vertical and horizontal, solid and dashed lines with a variety of thickness, logos, and special alphanumeric print features.

Variable Barcodes allow the barcode for your application to print with standard or user-defined ratios in vertical or horizontal orientations. Available barcodes are Codabar, Code 39, Code 93, Code 128 with Subsets A, B, and C, and Code EAN/UCC 128, EAN 8, EAN 13, Interleaved 2 of 5, MSI, UPC-A, UPC-E, POSTNET, PostBar, Royal Mail, and UPC Shipping. POSTNET is available only in the horizontal direction. A dark print mode is included for darker, high-contrast barcodes. The IBARC barcode command prints barcodes in four orientations: horizontal, rotated 90, rotated 180, or rotated 270 degrees.

Expanded and Compressed Print draws attention where needed. Alphanumeric height and width are controlled independently for a tremendous range of character sizes up to 9.9 inches wide and tall. Several compressed print sizes are available: 12, 13.33, 15, 17.65, and 20 (dpi), permitting up to 170 columns in an 8.5 inch printed area (20 dpi).

Rotated Alphanumerics permit new concepts in form design. Normal, expanded, and compressed character strings can be rotated 90 degrees clockwise, counterclockwise, or printed upside down.

Configuring The Emulation With The Control Panel

Logos are easily created using alphanumeric commands and a variety of print and shading features, which provides a “customized” appearance for forms, reports, and labels. The registered trademark, copyright, TUV[®], GS-Mark, UL[®], and CSA[®] symbols are provided as standard designs on the VGL, and you can also define custom symbols.

Reverse and Shaded Print permit highlighting and contrasting by printing white characters on a dark background or white characters on a gray, shaded background. Various levels or patterns of gray shading and reverse printing may combine with the many other print features to create distinctive designs.

Automatic Increment/Decrement Capability allows batch form processing. Individual alphabetic, numeric, and barcode data fields can be identified and automatically incremented or decremented by any amount, beginning from a specified reference point.

Standard Character Sets provide you with many different character sets. Based on the Multinational Character Set, you can create your own character sets using characters defined and stored in flash memory.

Configuring The Emulation With The Control Panel

You can select VGL default parameters directly from the control panel or by control codes as explained in the *IGP/VGL Programmer's Reference Manual*. The VGL parameters are described on the following pages. Parameters marked with an asterisk (*) indicate the default value. The printer must be offline to enter the configuration structure.

IMPORTANT **BEFORE you reconfigure the IGP/VGL, print a configuration sheet to see all of the current settings.**

Pressing an invalid key to enter a parameter value may move you to another level in the configuration menu or exit the menu completely.

Chapter 4 IGP/VGL Emulation

IGP/VGL Submenu

* = Factory Default

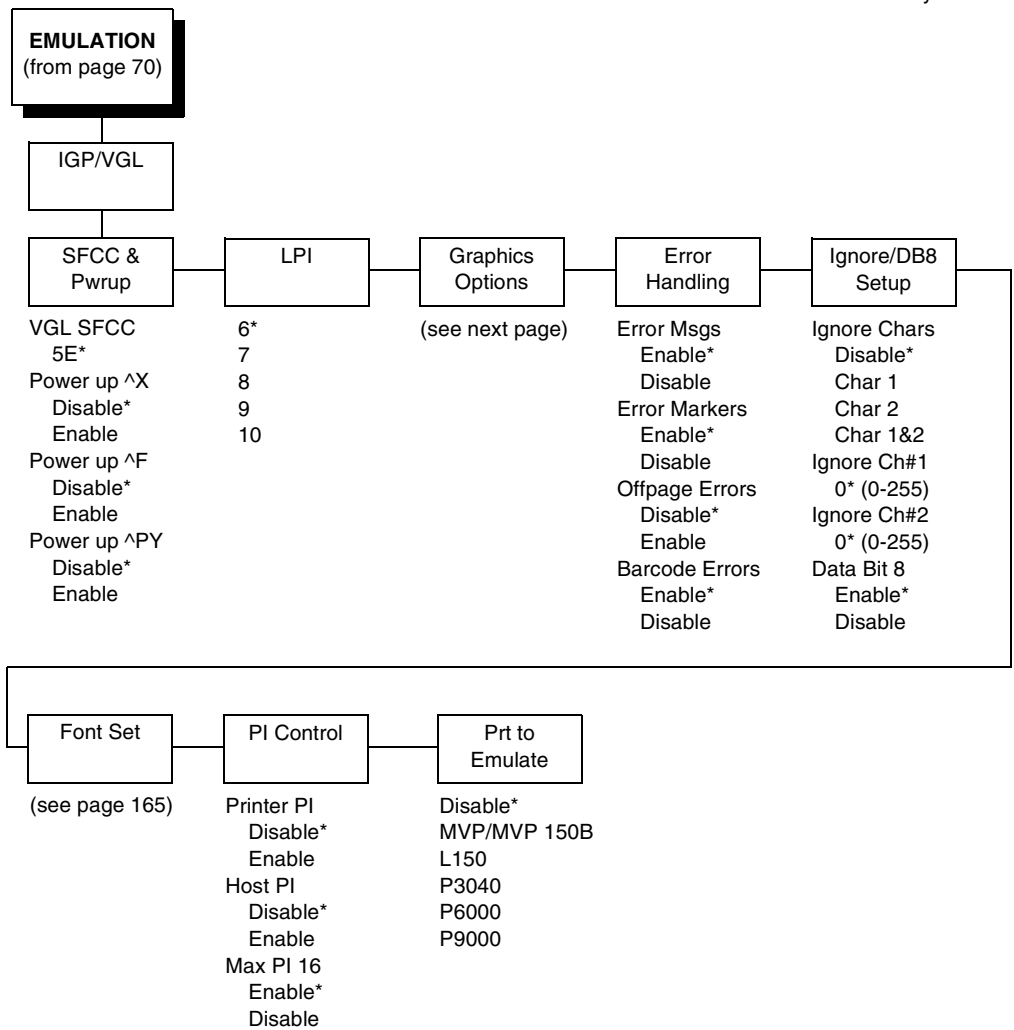

IGP/VGL Submenu

* = Factory Default

Graphics Options (from page 148)

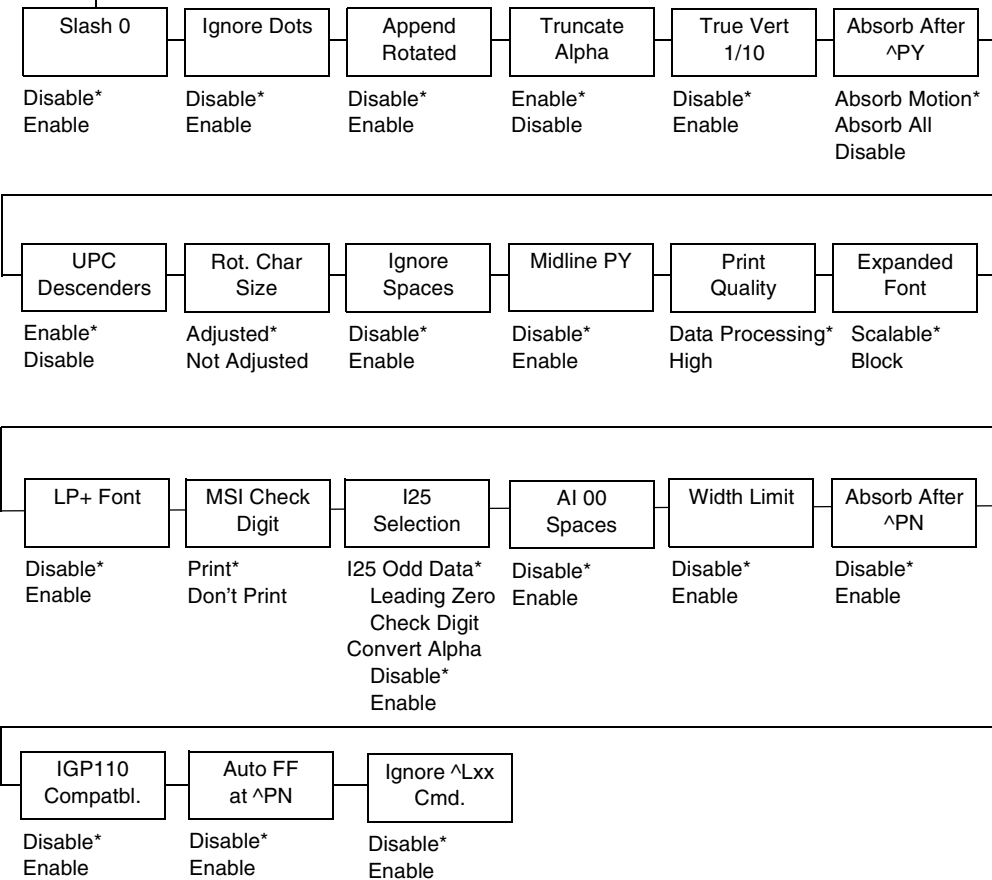

Chapter 4 IGP/VGL Emulation

IGP/VGL Submenu (with PCL-II)

* = Factory Default

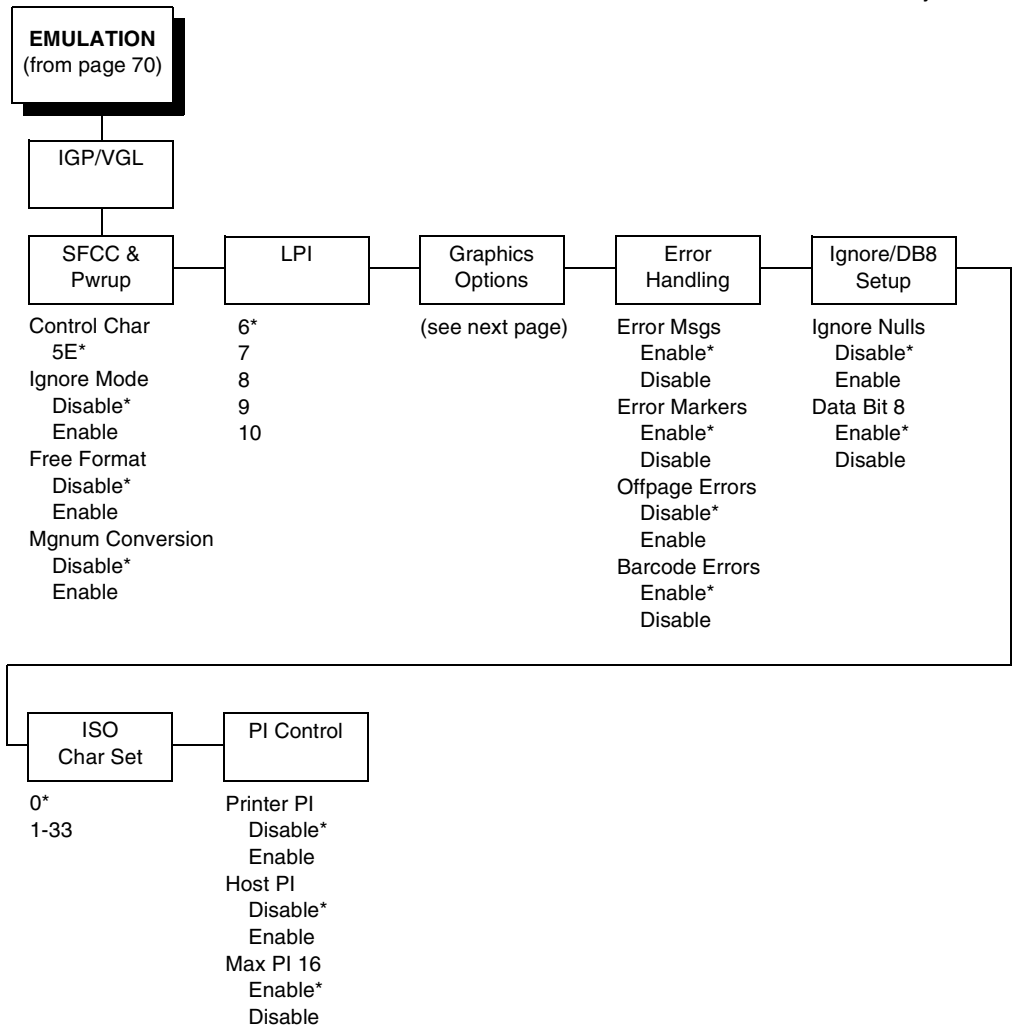

IGP/VGL Submenu (with PCL-II)

Graphics Options (from page 150)

* = Factory Default

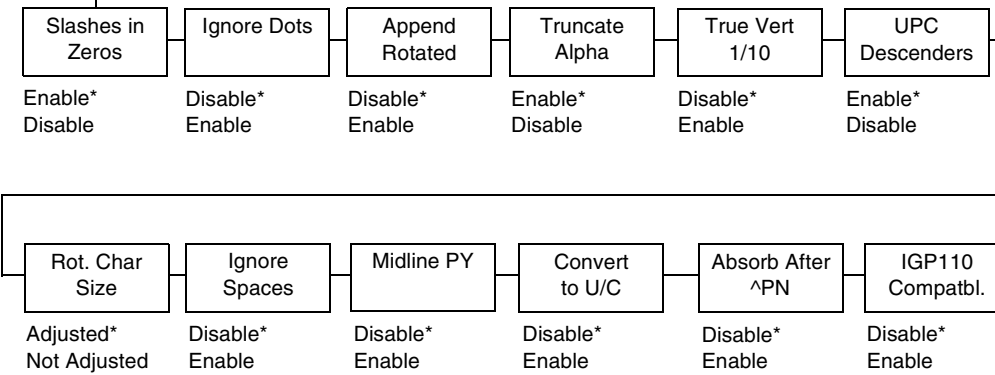

Chapter 4 IGP/VGL Emulation

IGP/VGL Submenu (with LG)

* = Factory Default

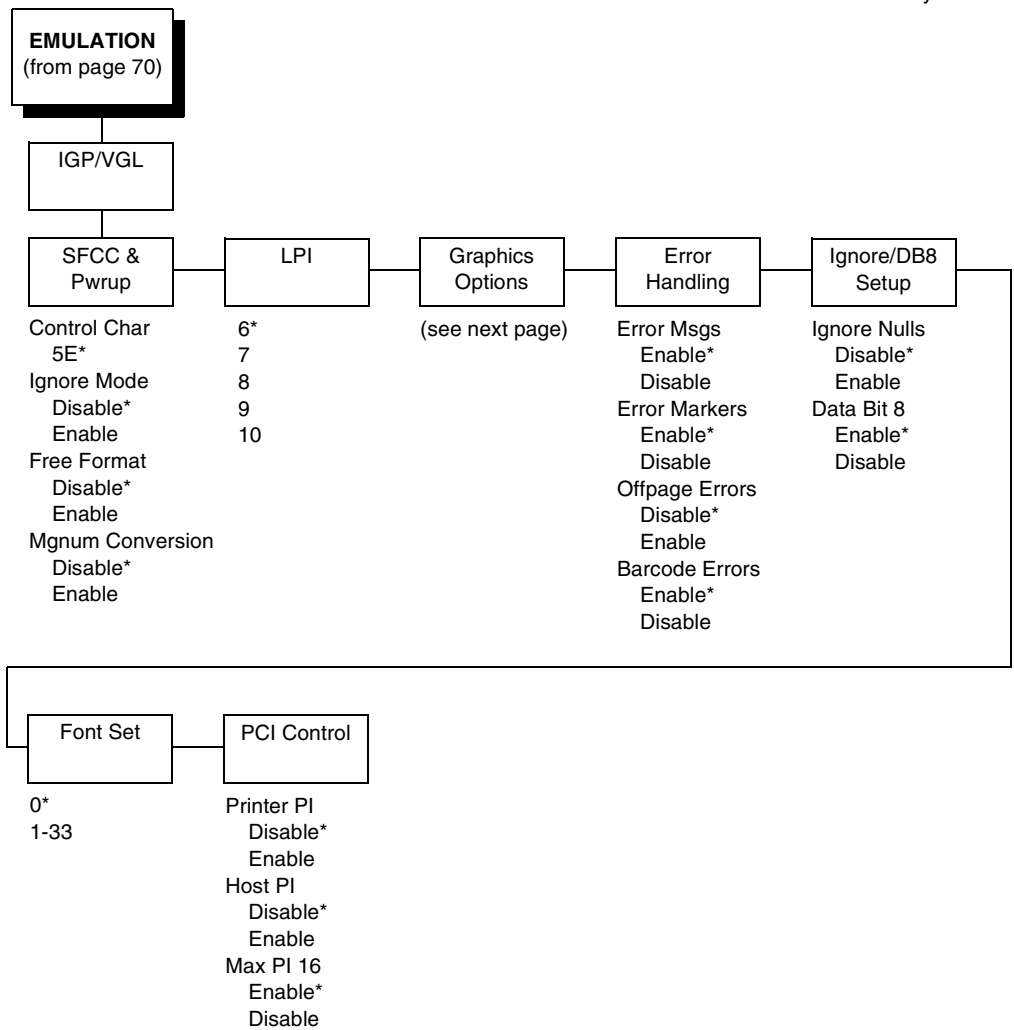

IGP/VGL Submenu

Graphics Options (from page 152)

* = Factory Default

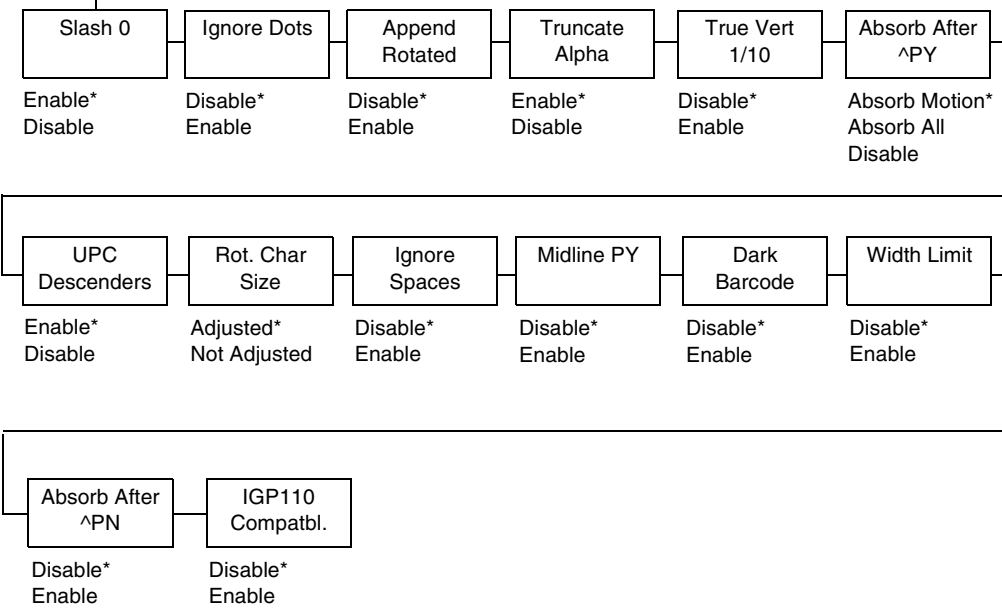

SFCC & Pwrup

This option has several sub-options which define the SFCC and power-up configuration used with VGL.

VGL SFCC

This option selects the Special Function Control Code. The default value 5E. Run a configuration printout to determine the currently selected VGL SFCC.

Power Up ^X

- **Disable** (default).
- **Enable**. Selects the ignore mode as the power-up default and selects the graphics mode ^PY as the power-up default. All characters are ignored until a ^A command is received.

Power Up ^F

- **Disable** (default).
- **Enable**. Selects free format mode as the power-up default and selects the graphics mode ^PY as the power-up default. Free format causes the VGL to ignore carriage returns, line feeds, and all characters below hex 20 sent from the host.

Power Up ^PY

- **Disable** (default).
- **Enable**. Selects the graphics mode ^PY as the power-up default.

LPI

The number of lines to be printed per inch. For example, at 6 lpi there is 1/6 inch from the top of one print line to the top of the next print line.

Graphics Options

Following are several options which configure printing output.

Slash 0

This parameter allows you to print the numeral “0” with or without the slash. This option applies to all character sets except OCR-A and OCR-B.

- **Disable** (default). Zero is printed without a slash.
- **Enable**. Zero is printed with a slash.

Ignore Dots

- **Disable** (default).
- **Enable**. Causes the VGL to expect position values to be specified in only 1/10ths of an inch. If the dot position is also given, it is treated as text.

Append Rotated

- **Disable** (default). Logos and alphanumeric strings are treated as separate elements.
- **Enable**. Appends logos to an alphanumeric string rotated in a clockwise, counterclockwise, or inverted orientation.

Truncate Alpha

When enabled, this parameter prevents the printing of Error 48 (Element Off Page Error) if alphanumeric data, including spaces, extends beyond the right side of the form. The options include:

- **Enable** (default)
- **Disable**

True Vert 1/10

- **Enable** (default). A vertical 1/10 inch parameter is used as 1/10 inch. Rounding occurs to the nearest 1/72 inch. This can cause vertical moves that have the same value to differ by $\pm 1/72$ inch.
- **Disable**. A vertical 1/10 of an inch parameter is used as 7/72 of an inch. The absolute move is slightly smaller than expected. For example, a one-inch move would be 70/72 of an inch. Vertical moves that have the same value are identical in length.

Absorb After ^PY

- **Absorb Motion** (default). The first paper motion following a ^PY command is ignored.
- **Absorb All**. The system ignores all the data and terminator until a host generated motion terminator is detected.
- **Disable**. System terminators following a graphics command are sent to the printer and result in paper motion.

UPC Descenders

- **Enable** (default). UPC/EAN barcodes are printed with descenders, even if there is no human readable data.
- **Disable**. UPC/EAN barcodes are printed without descenders if there is no human readable data.

Rot. Char Size

- **Adjusted** (default). Rotated (clockwise/counterclockwise), expanded characters have a different size than an unrotated character with the same size parameters.
- **Not Adjusted**. Rotated, expanded characters are the same size as unrotated characters with the same size parameters.

Ignore Spaces

- **Disable** (default). Trailing spaces are not deleted from alphanumeric elements in a graphics pass.
- **Enable**. Trailing spaces are deleted from alphanumeric elements in a graphics pass.

Midline PY (includes ^PN)

- **Disable** (default). The Graphics mode Enable command, ^PY, must be the first three characters of a line.
- **Enable**. The ^PY or ^PN can occur anywhere in a line.

Print Quality

- **Data Processing** (default). ALPHA text and barcodes are printed in normal mode at 60 x 72 dpi. This mode should be set if the highest speed is desired.
- **High**. ALPHA text and barcodes are printed in dark mode at 120 x 72 dpi.

Expanded Font

- **Scalable** (default). These expanded characters have rounded edges.
- **Block**. These are block characters compatible with IGP-X10 printers.

LP+ Font

- **Disable** (default). The IGP/VGL uses its default half-dot font, which is slightly different from the standard bitmap font used by LP+ at 12, 13, 15 and 17 cpi.
- **Enable**. The IGP/VGL uses the same font as used by LP+ at all cpi.

MSI Check Digit

- **Print** (default). The check digit is appended at the end of the printable data field for MSI barcodes.
- **Don't Print**. The check digit for MSI barcodes does not print.

I25 Selection

- **I25 Odd Data** (default). When an odd number of data is provided, the default setting, Leading Zero, will add a zero to the beginning of the bar code data. The setting, Check Digit, will add a check digit to the end of the bar code data so that the results add up to an even number of data.
- **Convert Alpha**. Disable is the default. When enabled, each non-digit I25 bar code character will convert to "0."

NOTE: If you use an Interleaved 2/5 barcode that automatically adds the check digit (type code k or l, IBARC type code INT2/5CD or INT2/5CDA), the check digit is added regardless of how this parameter is set.

AI 00 Spaces

This option is designated for EAN/UCC-128 barcodes whose application identifier (AI) is 00.

- **Disable** (default). The printable data field is printed with the AI enclosed in parentheses. This is the standard EAN/UCC-128 format.
- **Enable**. The printable data field is printed with the UCC fields separated by spaces. This option is IGP-X00 compatible.

Width Limit

- **Disable** (default).
- **Enable**. The system will limit the length and width for expanded characters to a limit shown in Table 6, which displays the maximum width allowed for a specific height in the range of 00 through 40 (0.0 through 4.0 inches).

Table 6. Width Limit Table

Height Param.	Max. Width Allowed	Height Param.	Max. Width Allowed
00	99	21	51
01	99	22	53
02	3	23	56
03	6	24	58
04	8	25	61
05	11	26	63
06	13	27	66
07	16	28	68
08	18	29	71
09	21	30	73
10	23	31	76
11	26	32	78
12	28	33	81
13	31	34	83
14	33	35	86
15	36	36	88
16	38	37	91
17	41	38	93
18	43	39	96
19	46	40	98
20	48		

Chapter 4 IGP/VGL Emulation

Absorb After ^PN

- **Disable** (default). All line terminators that follow the ^PN command are sent to the printer and processed.
- **Enable**. The first motion line terminator that follows the ^PN command is ignored.

IGP110 Compatbl.

This option instructs the VGL to behave similarly to the IGP-10 with respect to certain commands. All new users with new applications should select the “Disable” option. Selecting this mode insures the printer will behave as described in this manual.

- **Disable** (default). The IGP does not emulate the IGP-10 mode.
- **Enable**. The IGP emulates the IGP-10 version.

Auto FF at ^PN

- **Disable** (default). A form feed will not be generated automatically when the ^PN command is encountered.
- **Enable**. A form feed will be generated automatically to slew to the top of the next form when the ^PN command is encountered and when the current vertical position is not at top of form.

Ignore ^Lxx Cmd.

- **Disable** (default).
- **Enable**. The ^Lxx command will always be ignored.

Error Handling

Following are several options which define how errors are reported.

Error Msgs

- **Enable** (default). Command syntax is checked and error messages printed when command parameters are incorrect.
- **Disable**. Error checking and error messages are suppressed.

Error Markers

- **Enable** (default). Prints the following error markers for those elements that print beyond the page boundaries:
 - >> for elements that begin off the right side of the page;
 - << for elements that begin at the indicated position but end off the page; ◆ for elements where the starting position of the command contains an error other than an off-page error.

Offpage Errors

- **Disable** (default). Does not report errors for elements that start or end beyond the right edge of the page.
- **Enable**. Reports errors for elements that start or end beyond the right edge of the page.

Barcode Errors

- **Enable** (default). An error message will print when invalid barcode data is encountered.
- **Disable**. VGL will not print an error for illegal barcode data; the barcode will be skipped.

NOTE: When the Barcode Errors option is disabled, the VGL emulation will try to make the best use of invalid data by either truncating extra digits or adding zeros to the end of barcode data to meet minimum data length requirements for some barcodes. Not all errors will be corrected.

Ignore / DB8 Setup

Following are several options which define character filtering and Data Bit 8.

Ignore Chars

- **Disable** (default). Character filtering is not enabled.
- **Char 1**. Character 1 will be filtered. Select the option “Ignore CH#1” to specify character 1.
- **Char 2**. Character 2 will be filtered. Select the option “Ignore CH#2” to specify character 2.
- **Char 1 & 2**. Characters 1 & 2 will be filtered. Select the options “Ignore CH#1” and “Ignore CH#2” to specify values for these characters.

Ignore CH#1

Specifies character 1 for the character filtering option. Valid decimal values are from 0 through 255.

Ignore CH#2

Specifies character 2 for the character filtering option. Valid decimal values are from 0 through 255.

Data Bit 8

- **Enable** (default). The PI line is not passed directly from host to printer; all 8 bits are used for data bits, and characters in the hex 80-FF range can be accessed.
- **Disable**. When the host PI line is enabled, Data Bit 8 internally indicates PI line status. To use the PI line, disable Data Bit 8, and enable the Host PI configuration option (under the PI Control option, below).

NOTE: Data Bit 8 is interpreted as either Data Bit 8 or PI signal, but never both. When enabled as Data Bit 8, Data Bit 8 has priority over the PI signal, and all data above hex 7F is used to access character data and not to interpret PI line data.

Conversely, when Data Bit 8 is disabled and the PI signal is used, Data Bit 8 of the data is reserved for use as the PI function, and you cannot access characters in the hex 80-FF range. Therefore, to access characters in the hex 80-FF range, Data Bit 8 must be enabled.

Font Set

The Font Set specifies which language is currently selected for use with the VGL. Refer to "IGP/VGL Font Set Menu" on page 165 for available selections.

PI Control

Printer PI

- **Disable** (default). The ASCII emulation is configured with the PI line disabled.
- **Enable**. The ASCII emulation is configured with the PI line enabled.

Host PI

- **Disable** (default). The host does not send PI signals.
- **Enable**. The host sends PI signals. The Data Bit 8 configuration option must be disabled to transmit the PI line to the printer.

Max PI 16

- **Enable** (default). A paper slew of 0-15 will move 1-16 lines.
- **Disable**. A paper slew of 1-15 will move 1-15 lines. A paper slew of 0 will always move 1 line.

Prt To Emulate

This option allows you to select an earlier model printer/IGP board combination to emulate. When a printer emulation is selected, the scaling command causes the printer to generate a graphic image in the same density as the printer emulation chosen. Five types of printers can be emulated: MVP or MVP 150B, L150, P3040, P6000, and P9000. Once a printer emulation is selected, it remains active until the printer is turned off or another printer emulation is selected. All new users with new applications should select the "Disable" option, which insures the printer behaves as described in this manual. The other compatibility modes are required to emulate the behaviors of older printers which may be inconsistent with the documented VGL functionality. Proper use of this feature requires the printer to be equipped with high resolution hammer bank tips (12 mil).

IGP/VGL Font Set Menu

* = Factory Default

Font Set
(see page 148)

Standard Sets*

- 0) ASCII*
- 1) German
- 2) Swedish
- 3) Danish
- 4) Norwegian
- 5) Finnish
- 6) English
- 7) Dutch
- 8) French
- 9) Spanish
- 10) Italian
- 11) Turkish
- 12) CP 437
- 13) CP 850

Arabic Sets

- ASMO 449*
- ASMO 449+
- ASMO 708
- ASMO 708+
- MS DOS CP710
- MS DOS CP720
- Sakr CP 714
- Aptec CP715
- CP 786
- Arabic CP 864
- Arabic CP 1046
- Arabic Lam 1
- Arabic Lam 2
- Win. CP 1256
- Farsi 1
- Farsi 2
- 1098 Farsi 1285

Cyrillic Sets

- Code Page 866*
- Cyrillic CP 437
- Cyrillic 113
- Cyrillic 8859-5
- ISO 915
- Code Page 855
- 7-bit Cyrillic
- Ukrainian
- Bulgarian
- Win. CP 1251

European Sets

- Latin 2 8859-2*
- Latin 2 852
- Mazovia
- Kamenicky
- Roman 8
- PC-437 Slavic
- Slavic 1250
- Code Page 865
- Code Page 860
- Latin 1 8859-1
- Latin 5 8859-9
- Latin 9 8859-15
- Polish POL1
- Win. CP 1250
- Win. CP 1252
- Win. CP 1257
- CP 858 EURO
- Lith. CP 773
- Serbo Croatic 1
- Serbo Croatic 2
- CP 774
- CP 775
- ISO 8859-4

Greek Sets

- DEC 256 Greek*
- ELOT 928 Greek
- Greek 3
- ABY Greek
- ABG Greek
- ELOT 927 Greek
- Greek 851
- Greek 437
- Greek 8859-7
- Win. CP 1253
- Greek 813 EURO
- Greek 869 EURO

Hebrew Sets

- Hebrew Old*
- Hebrew New
- Hebrew DEC
- Latin-1 Hebrew
- Win. CP 1255

Turkish Sets

- Data Gen. Turk.*
- DEC Turkish
- IBM Turkish
- Siemens Turkish
- PTT Turkish
- IBC Turkish
- Bull Turkish
- AS400 Turkish

Misc. Sets

- Unisys Turkish
- NCR Turkish
- PST Turkish
- UNIS-1 Turkish
- Code Page 853
- INFO Turkish
- Win. CP 1254
- Code Page 857

Misc. Sets

- Block-set 10cpi*
- Italics Set
- Scanblock 10cpi
- PGL Thai Set

Chapter 4 EMULATION

EMULATION

The EMULATION menu allows you to select the emulation to be used with your printer. The Proprinter XL, Epson FX, P-Series, P-Series XQ, and Serial Matrix emulations are all part of LinePrinter+. You can configure options for the active emulation via the EMULATION menu. Emulation options are further described in their corresponding Programmer's Reference Manual.

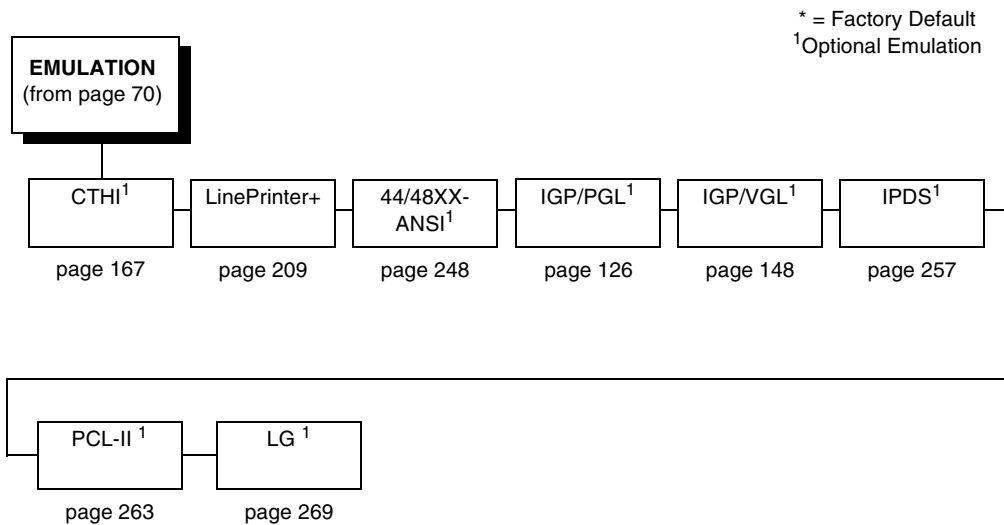

Coax/Twinax (CTHI) Emulation

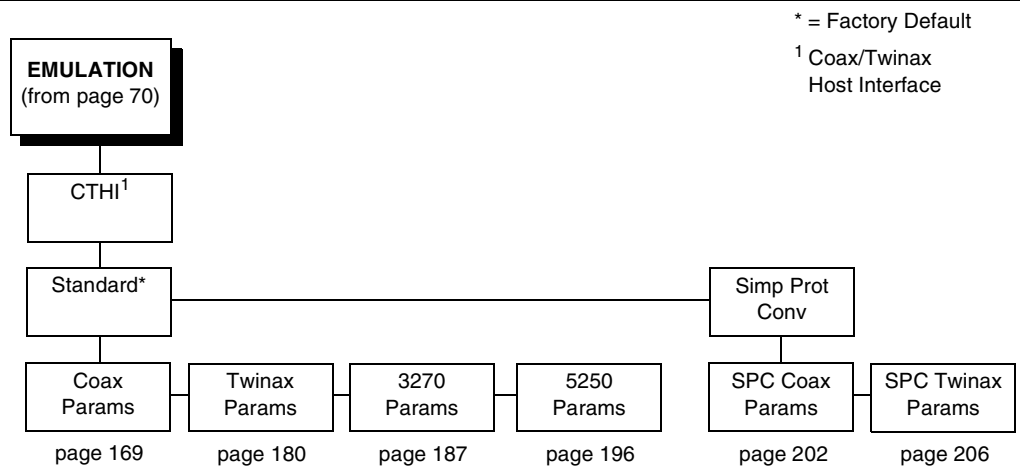

Standard

With a standard coax interface, the printer emulates the following IBM coax printer models:

- 3287 Models 1 and 2
- 4234 Model 1

With a standard twinax interface, the printer emulates the following IBM twinax printer models:

- 4234 Models 2 and 12
- 5225 Models 1, 2, 3, and 4

NOTE: The standard Coax/Twinax emulation selection will only be available if Coax or Twinax is selected from the HOST INTERFACE menu. See page 85.

For more information, refer to the *Coax/Twinax Programmer's Reference Manual*.

The 3270 Params and 5250 Params selection is available only if the TN option is installed.

Simple Prot Conv

The Simple Protocol Converter (SPC) option allows those who use third party add-on Coax or Twinax protocol converters to produce the same output on a Line Matrix printer with the Coax/Twinax (CTHI) capability as done using a non-CT printer with the third party converter interfaces.

The SPC replaces the third party add-on protocol converters attached to older line matrix printers.

The SPC gives the printer the operational ability to connect to any PC, or network system supporting parallel or serial interfaces, and to three different IBM host systems: System 3x, AS/400[®], and 3270 Mainframes.

The SPC will support the following third party models for Twinax: MODE 219, MODE IBM, and MODE PROLINE.

The printer emulations supported by the SPC are Twinax 5225 and Coax 3287. The SPC also provides a range of interfaces available in your line matrix printer: Centronics, Dataproducts, Serial, Coax, and Twinax. Also supported are Epson, Proprinter, P-Series, Serial Matrix, IGP/VGL, and IGP/PGL emulations.

The SPC has the ability to handle multiple print jobs concurrently through Coax/Twinax and Parallel and Serial interfaces. This is accomplished through the Auto Switching feature (see page 86). Because of hardware restrictions, Coax and Twinax cannot be selected together.

For more information, consult the *Coax/Twinax Programmer's Reference Manual* for the Simple Protocol Converter Option.

Coax Emulation

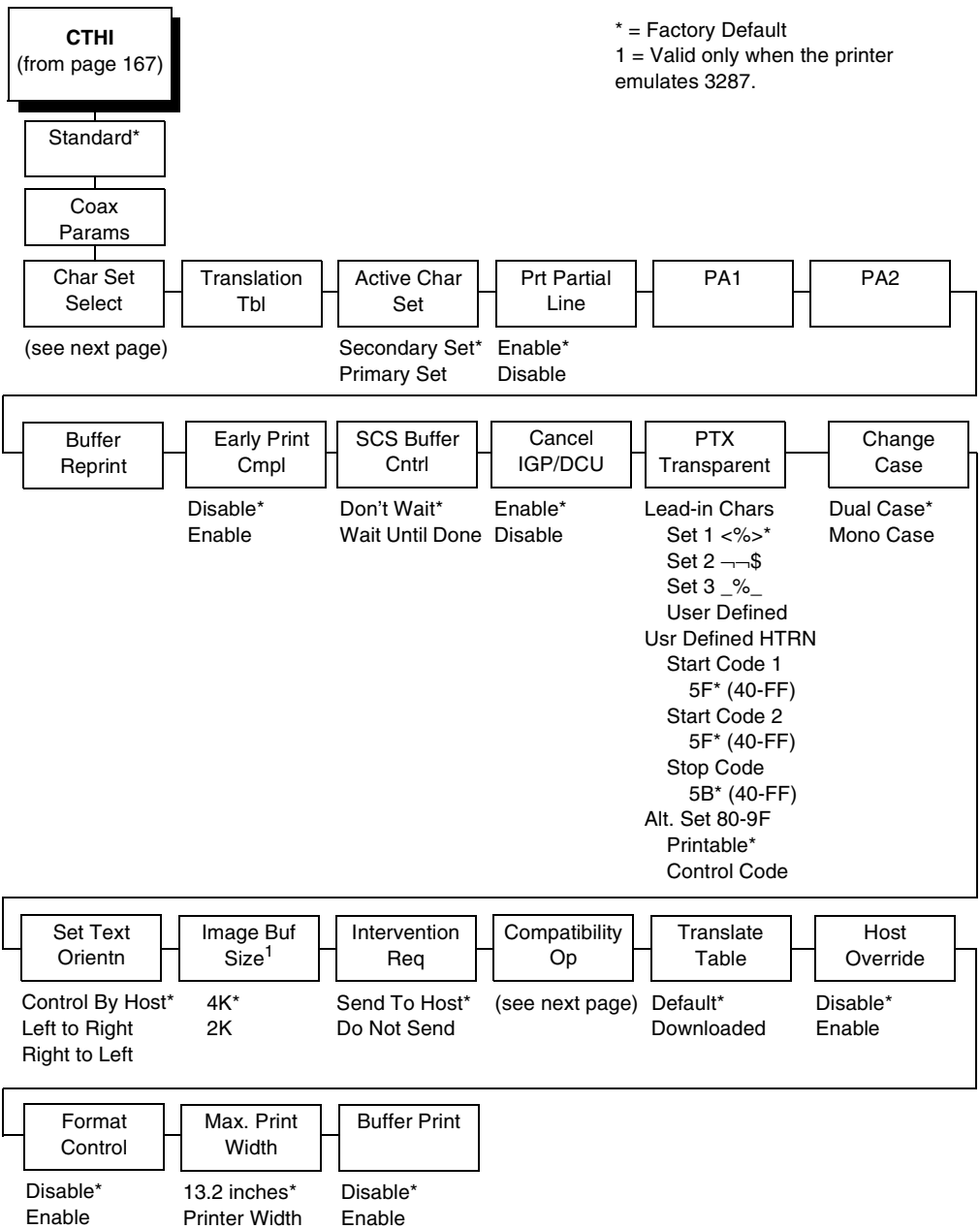

Chapter 4 Coax/Twinax (CTHI) Emulation

* = Factory Default

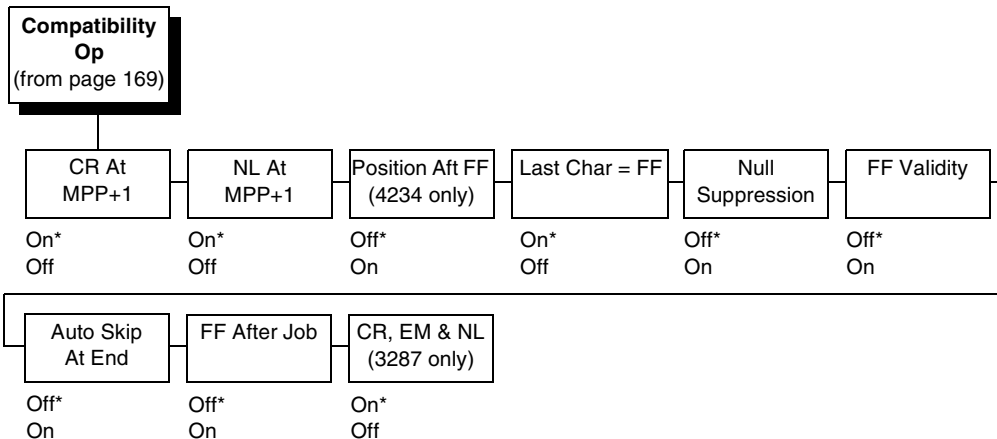
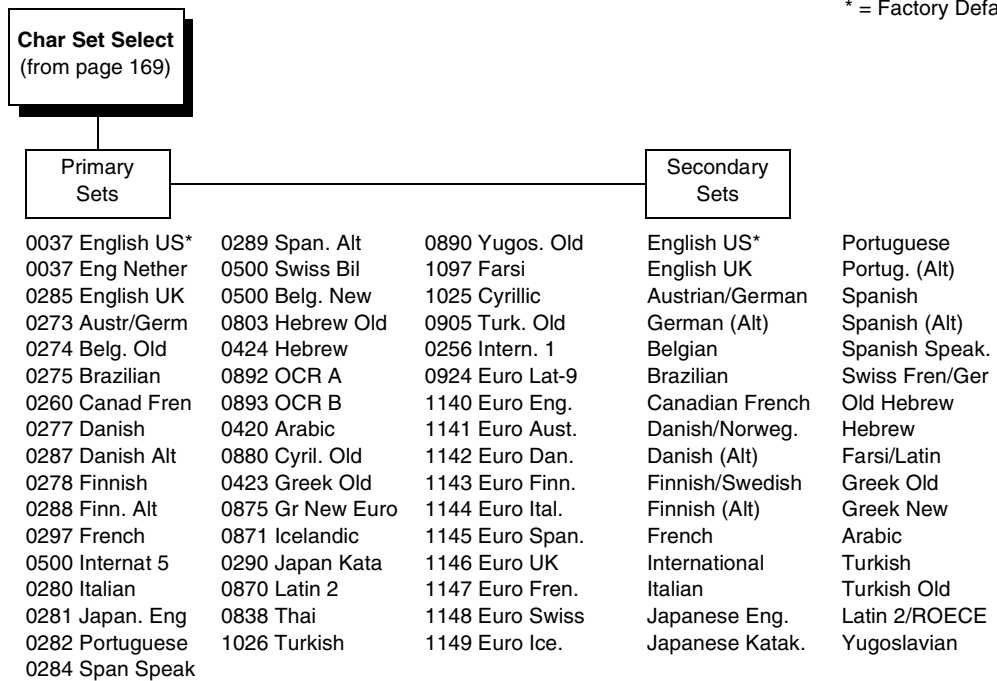

Char Set Select

Specifies the print language used by the printer. Character sets are shown in detail in the *Character Sets Reference Manual*.

Translation Tbl

Prints out SCS and DSC/DSE tables of the Coax interface's current character set. This operation is valid only when the Coax interface is selected as the current interface (see "HOST INTERFACE" on page 85).

Active Char Set

Selects which group of character sets (Primary or Secondary) will be active. Secondary Set is the default.

Prt Partial Line

- **Enable** (default). Forces the printer to print if a partial line is in the printer (i.e., line not ending with a LF).
- **Disable**. The last partial line of data will not be printed.

PA1

PA1 is only valid when the printer is in the offline state and the coax Systems Network Architecture Character String (SCS) data stream is active. This function displays the "PA1 ENABLED" message when the ENTER key is pressed and sends a special operator request to the host when the printer is put back in Online mode. Refer to the *Coax/Twinax Programmer's Reference Manual* for more information about SCS.

NOTE: Selecting the PA1 menu item again ("PA1 DISABLED" appears on the operator panel) or selecting the PA2 menu item will reset the pending PA1 function.

PA2

PA2 is only valid when the printer is in the Offline state and the coax SCS data stream is active. This function displays the “PA2 ENABLED” message when the ENTER key is pressed and sends a special operator request to the host when the printer is put back in online mode.

NOTE: Selecting the PA2 menu item again (“PA2 DISABLED” appears on the operator panel) or selecting the PA1 menu item will reset the pending PA2 function.

Buffer Reprint

This option is valid only when the printer is printing in SCS mode. When the ENTER key is pressed, “Buffer Reprint Enabled” is displayed and an Intervention Required status is sent to the host. Pressing ENTER again cancels the Buffer Reprint function and displays “Buffer Reprint Disabled.”

Early Print Cmpl

Allows the printer to send print (order) complete status to the host before the printer is actually done printing all data. This option is valid only when the printer is in DSC/DSE mode.

- **Disable** (default). The printer will suppress the Early Print Complete response until all printing is complete.
- **Enable**. The printer will send an acknowledgment to the host when it is able to accept more data.

NOTE: When Early Print Complete is enabled and an error occurs, you may lose data.

SCS Buffer Cntrl

This option is used in Coax LU1/SCS mode only.

- **Don't Wait** (default). The printer does not wait for the job to be printed before sending the print completion to the host.
- **Wait Until Done**. The printer waits for the job to print before sending the print completion to the host.

This option speeds up the LU1 job printing for short jobs. If you select "Don't Wait," there is a risk that you may not be able to recover the print job when the printer has fault.

Cancel IGP/DCU

- **Enable** (default). Cancels all buffers when a job is put on hold from the host or when the CANCEL key is pressed.
- **Disable**. Does not cancel any internal buffer in the printer when a job is put on hold from the host or when the CANCEL key is pressed.

PTX Transparent

Lead-in Chars

You can enable additional printer features which are not accessible through standard Coax emulations. To access these features, send text commands in the data stream. The commands must have a start and end code. Four sets are available:

- **Set 1.** start code: <%
stop code: >
- **Set 2.** start code: ␣␣
stop code: \$
- **Set 3.** start code: _%
stop code: _
- **User Defined.**

Chapter 4 Coax/Twinax (CTHI) Emulation

Usr Defined HTRN

This option is used in Twinax SPC emulation. The range is ASCII character. This option allows users to define their own lead-in characters for the Printronix Specific commands. Select a hex value for the following codes for the User Defined option:

- **Start Code 1 5F**
- **Start Code 2 5F**
- **Stop Code 5B**

Alt. Set 80-9F

- **Printable.** Prints data in the range of hex 80 through hex 9F.
- **Control Code.** Interprets data in the range of hex 80 through hex 9F as a control code.

Change Case

Specifies the font as Mono or Dual case. This option is available only in non-SCS mode. The host will be notified of the change when the printer is placed online. Mono Case prints the same as Dual Case if the character set is one of the following “right to left” sets: Katak., Hebrew, Old Hebrew, and Farsi. The default is Dual Case.

SCS (System Network Architecture Character String) mode is controlled by the host computer.

Set Text Orientn

Specifies the direction in which characters are printed on the page. This allows the printer to print languages which are printed right to left instead of left to right.

- **Control By Host** (default). Allows printers configured as a 4234 to use the “Set Text Orientation” command from the host.
- **Left to Right.**
- **Right to Left.** When a right to left language is selected, the host will be notified of print direction changes when the printer is placed online.

Image Buf Size

Allows you to select 2K or 4K as the image buffer size. This option is valid only when the printer emulates the 3287. For the 4234 emulation, the buffer size is fixed at 4K. A POR status is sent to the host when the printer is placed online.

Intervention Req

- **Send to Host** (default). The printer sends a signal to the host computer when a printer fault or hold mode time-out occurs.
- **Do Not Send**. No signal will be sent to the host computer.

Compatibility Op

The Compatibility Options allow you to select special printer functions in the non-SCS mode based on the capabilities of the printer emulated.

CR At MPP+1

MPP is Maximum Print Position, which is also known as line length. This option controls a carriage return at the end of a print line and at MPP+1.

- **On** (default). Produces a carriage return to the first print position of the next line.
- **Off**. Produces a carriage return to the first print position of the current line.

NL At MPP+1

Controls how many lines are skipped when the carriage returns to a new line.

- **On** (default). Moves to the first print position two lines down from the current position.
- **Off**. Moves to the first print position of the next print line.

Chapter 4 Coax/Twinax (CTHI) Emulation

Position Aft FF (4234 only)

Allows you to select the location of the print position after a form feed command is sent.

- **On** (default). Sets the printer to print at print position 1 of the first print line on the next form.
- **Off**. Sets the printer to print at print position 2 of the first print line on the next form.

Last Char = FF

Determines the print line position when a form feed command is the last code encountered in the print buffer.

- **On** (default). Moves to the first print position on the second line of the next form.
- **Off**. Moves to the first print position on the first line of the next form.

NOTE: This option is ignored if Auto Skip At End is on.

If configured as a 3287, and a form feed occurs in the middle of a print buffer, the printer defaults to the first print position on the second line of the next form regardless of the setting of this option.

Null Suppression

- **Off** (default). Ignores nulls. The print position does not move.
- **On**. Treats nulls as blank spaces.

FF Validity

Determines if the position of a form feed command affects its execution.

- **Off** (default). Performs a form feed only if it occurs at the first print position in a line or at Maximum Print Position +1. A form feed command at any other position is recognized as a space.
- **On**. Allows the printer to perform a form feed command anywhere in the data stream.

Auto Skip At End

Specifies whether or not to perform an automatic form feed at the end of a print buffer. If form feed is the last character in the print order, the form feed function is supplied by the Auto Skip At End option.

- **Off** (default). Sets the printer to print at print position 1 of the next line.
- **On**. Sets the printer to print at print position 1 of the first line of the next form.

FF After Job

Determines the print position after an operator-initiated local copy (print screen function).

- **Off** (default). Performs an automatic new line command after completing a print buffer (unless a new line, form feed, or carriage return command was the last one executed). The printer is set to print at print position 1 of the next line.
- **On**. Performs an automatic form feed command unless a form feed was the last one executed. The printer is set to print at print position 1 of the first line on the next form.

CR, EM, and NL (3287 only)

CR (Carriage Return), EM (Error Message), and NL (New Line) specify that the printer treat the CR, EM, and NL control codes either as spaces or as control codes.

- **On** (default). Treats the CR, EM, and NL commands as control codes.
- **Off**. Treats the CR, EM, and NL commands as spaces.

Translate Table

Defines which translate table to use for printing.

- **Default** (default). Translates data by using the default table of the current character set.
- **Downloaded**. Translates data from EBCDIC to internal code by using the downloaded translate table.

Host Override

Determines whether the printer accepts certain commands sent by the host or continues to use the current operator panel settings.

- **Disable** (default). Allows the following host commands to override operator panel settings: line length, forms length, lines per inch (LPI), characters per inch (CPI), print quality, and text orientation. Note the information appearing on the message display may not match the data stream setting. No values will change upon initial selection of the disable option.
- **Enable**. The operator panel settings override the host commands.

Format Control

Enables the printer to reflect the same spacing as CTPC model printers after absolute and relative move commands are executed.

- **Disable** (default). Reflects distance, generated by the IGP/VGL feature, IGP/PGL feature, and Hex Transparent control code sequence, in the new position (after horizontal and vertical tabs are executed).
- **Enable**. Does not reflect distance, generated by the IGP/VGL feature, IGP/PGL feature, and Hex Transparent control code sequence, in the new position (after horizontal and vertical tabs are executed).

Max. Print Width

Set the maximum print width at either 13.2 inches or the maximum width of the printer.

Buffer Print

- **Disable** (default). The printer will print normally.
- **Enable**. The printer prints the EBCDIC data and control codes received from the host as hex values. Refer to page 315 for information on how to obtain a hex code printout.

NOTE: Use of this parameter may alter print attributes set by the host computer. A power cycle may be required after changing Buffer Print from enable to disable.

Chapter 4 Coax/Twinax (CTHI) Emulation

Twinax Params

* = Factory Default

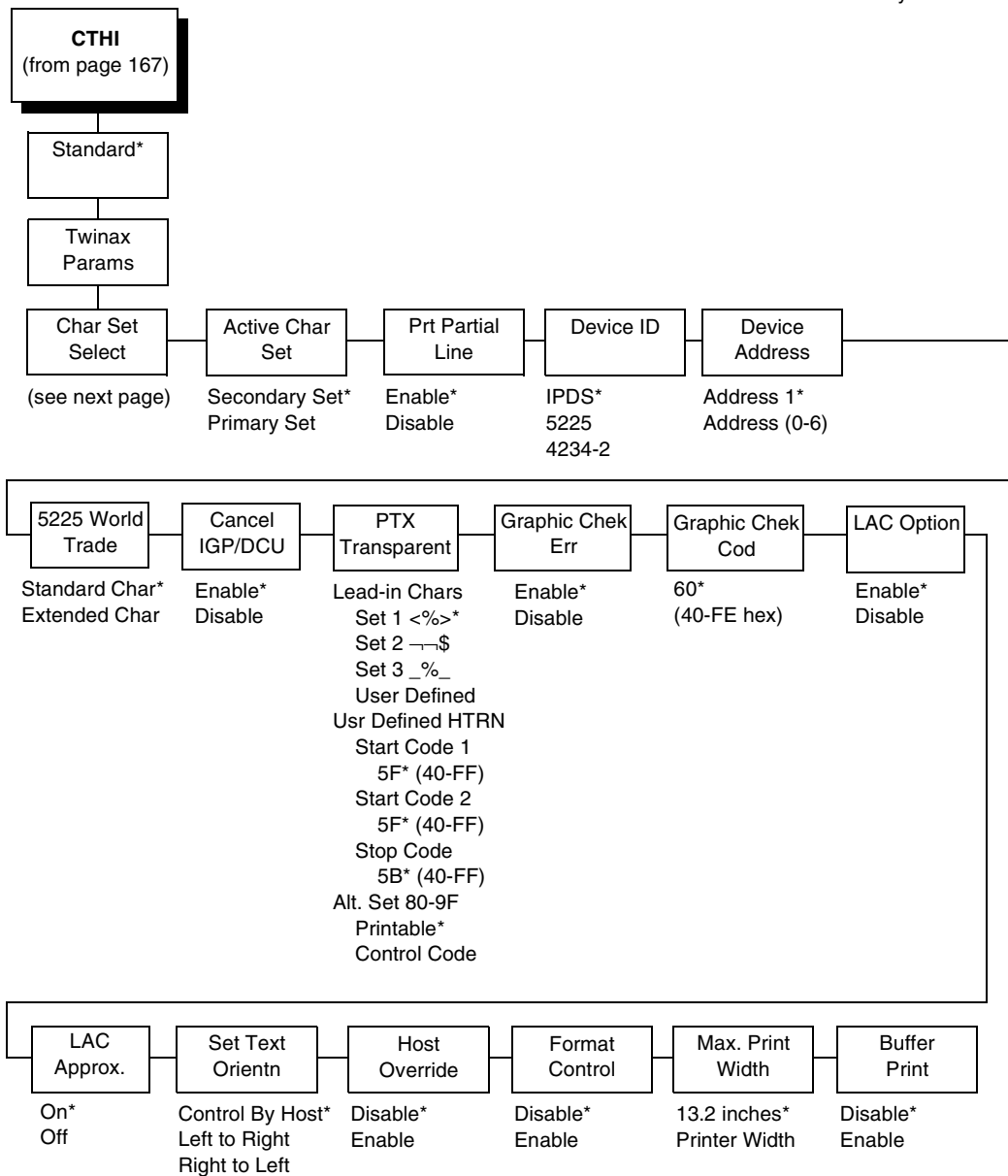

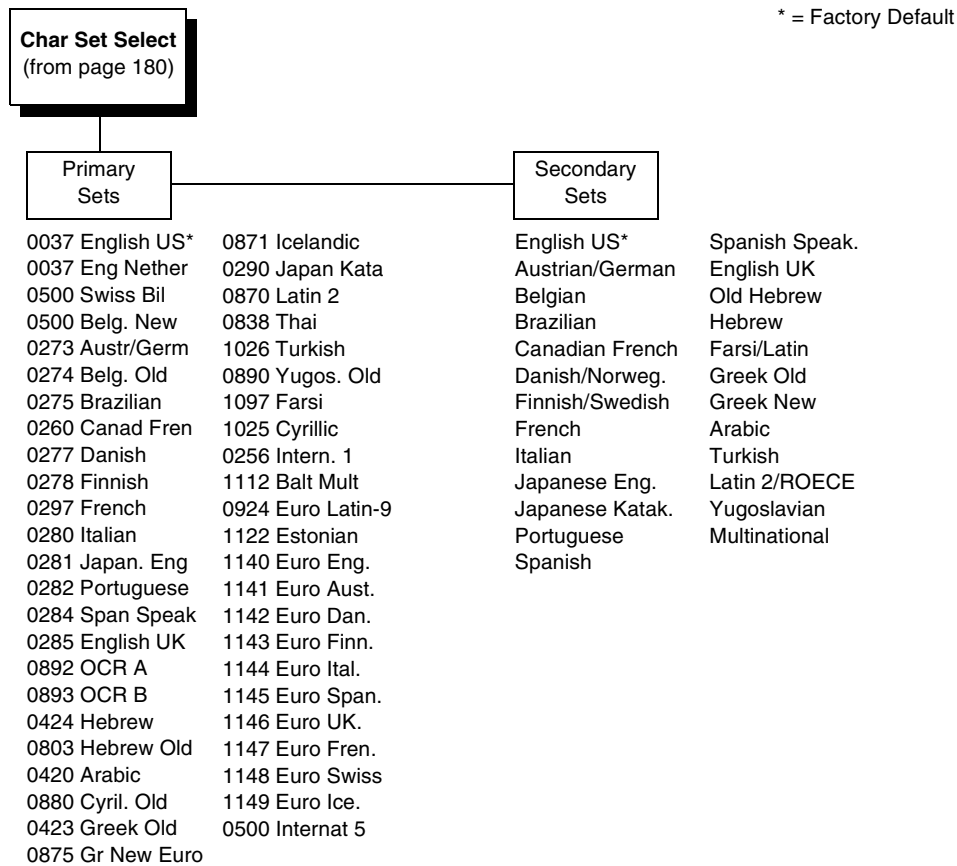

Char Set Select

Specifies the print language used by the printer. Character sets are shown in detail in the *Character Sets Reference Manual*.

Active Char Set

This option selects which group of character sets (Primary or Secondary) will be active. Secondary Set is the default.

Prt Partial Line

- **Enable** (default). Forces the printer to print a partial line (i.e., line not ending with a LF) before moving to the top of form on the next page.
- **Disable**. The last partial line of data will not be printed.

Device ID

This parameter defines the printer emulation as 4234-2 or 5225. After the emulation has been changed, a POR status is sent to the host. 4234-2 is the default.

Device Address

Allows you to set the device address from 0 through 6. The host directs data and commands on the twinax line to a specific device based on its unique device address. After the address has been changed, a POR status is sent to the host.

5225 World Trade

The 5225 emulation has a standard multinational character set that serves as a base and 14 extended world trade character set assortments.

Cancel IGP/DCU

- **Enable** (default). Cancels all buffers when a job is put on hold from the host or the CANCEL key is pressed.
- **Disable**. Does not cancel any internal buffer in the printer when a job is put on hold from the host or the CANCEL key is pressed.

PTX Transparent

Lead-in Chars

You can enable additional features that are not available in standard Twinax emulations. To access these features, send text commands in the data stream. The commands must have a start and end code. Three sets (each containing a start and end code) are available:

- **Set 1.** start code: <%
stop code: >
- **Set 2.** start code: ↵↵
stop code: \$
- **Set 3.** start code: _%
stop code: _
- **User Defined**

Usr Defined HTRN

This option is used in Twinax SPC emulation. The range is ASCII character. This option allows users to define their own lead-in characters for the Printronix Specific commands. Select a hex value for the following codes for the User Defined option:

- **Start Code 1 5F**
- **Start Code 2 5F**
- **Stop Code 5B**

Alt. Set 80-9F

- **Printable.** Prints data in the range of hex 80 through hex 9F.
- **Control Code.** Interprets data in the range of hex 80 through hex 9F as a control code.

Graphic Chek Err

Allows overriding of the host setting for the SGEA (Set Graphic Error Action) command. For more information about the SGEA command, refer to the *Coax/Twinax Programmer's Reference Manual*.

- **Enable** (default). The host setting for the SGEA used by the printer. If the SGEA command is requested to stop on graphic errors, the printer will stop when a graphic error is detected.
- **Disable**. Ignores the SGEA command from the host. The printer does not stop when an error is detected; instead, it substitutes the character selected in the Graphic Chek Code parameter.

Graphic Chek Cod

Specifies the replacement character to print in place of any unprintable character that is received from the host. Choose a hex character from 40 through FE. The character becomes the printer default when:

- the printer is powered off and then powered on;
- an SGEA command specifies to use the operator panel default;
- the Graphic Chek Err parameter is disabled.

LAC Option

Allows the host system to load alternate character images into the printer. This may be used for designing graphics, barcodes, and charts, or for printing in foreign languages.

- **Enable** (default). Prints the LAC character as defined.
- **Disable**. Ignores the LAC definition from the host and prints from the currently selected character set.

LAC Approx.

A process that reorganizes columns of dots so that clean, readable printing is possible.

- **On** (default). Converts the emulated character cells to standard cells for the P7224 model.
- **Off**. Converts character cells byte by byte and not by LAC approximation.

Set Text Orientn

Specifies the direction in which characters are printed on the page. This allows the printer to print languages that are printed right to left instead of left to right. The options include:

- **Control By Host** (default)
- **Left to Right**
- **Right to Left**

Host Override

Determines whether the printer accepts certain commands sent by the host or continues to use the current operator panel settings.

- **Disable** (default). Allows the following host commands to override operator panel settings: line length, forms length, lines per inch (LPI), characters per inch (CPI), print quality, and text orientation. Note the information appearing on the message display may not match the data stream setting. No values will change upon initial selection of the disable option.
- **Enable**. The operator panel settings override the host commands.

NOTE: Host margin and tab settings will take precedence whether or not Host Override is enabled.

Format Control

Enables the printer to reflect the same spacing as CTPC model printers after absolute and relative move commands are executed.

- **Disable** (default). Reflects distance, generated by the IGP/VGL feature, IGP/PGL feature, and Hex Transparent control code sequence, in the new position (after absolute and relative move commands are executed).
- **Enable**. Does not reflect distance, generated by the IGP/VGL feature, IGP/PGL feature, and Hex Transparent control code sequence, in the new position (after absolute and relative move commands are executed).

Max. Print Width

Set the maximum print width at either 13.2 inches or the maximum width of the printer. The default is 13.2 inches.

Buffer Print

- **Disable** (default). The printer will print normally.
- **Enable**. The printer prints the EBCDIC data and control codes received from the host as hex values. Refer to page 315 for information on how to obtain a hex code printout.

NOTE: Use of this parameter may alter print attributes set by the host computer. A power cycle may be required after changing Buffer Print from enable to disable.

3270 Params

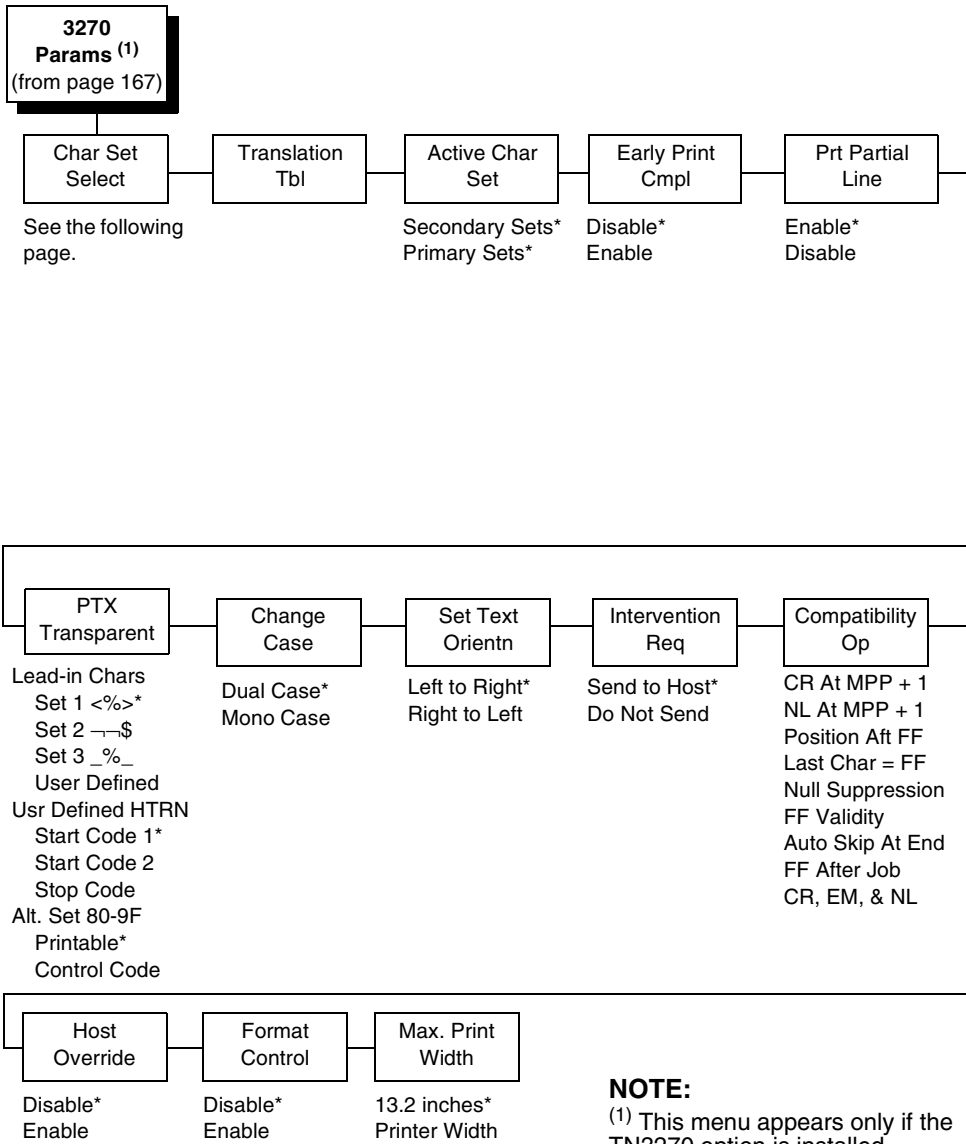

Chapter 4 Coax/Twinax (CTHI) Emulation

* = Factory Default

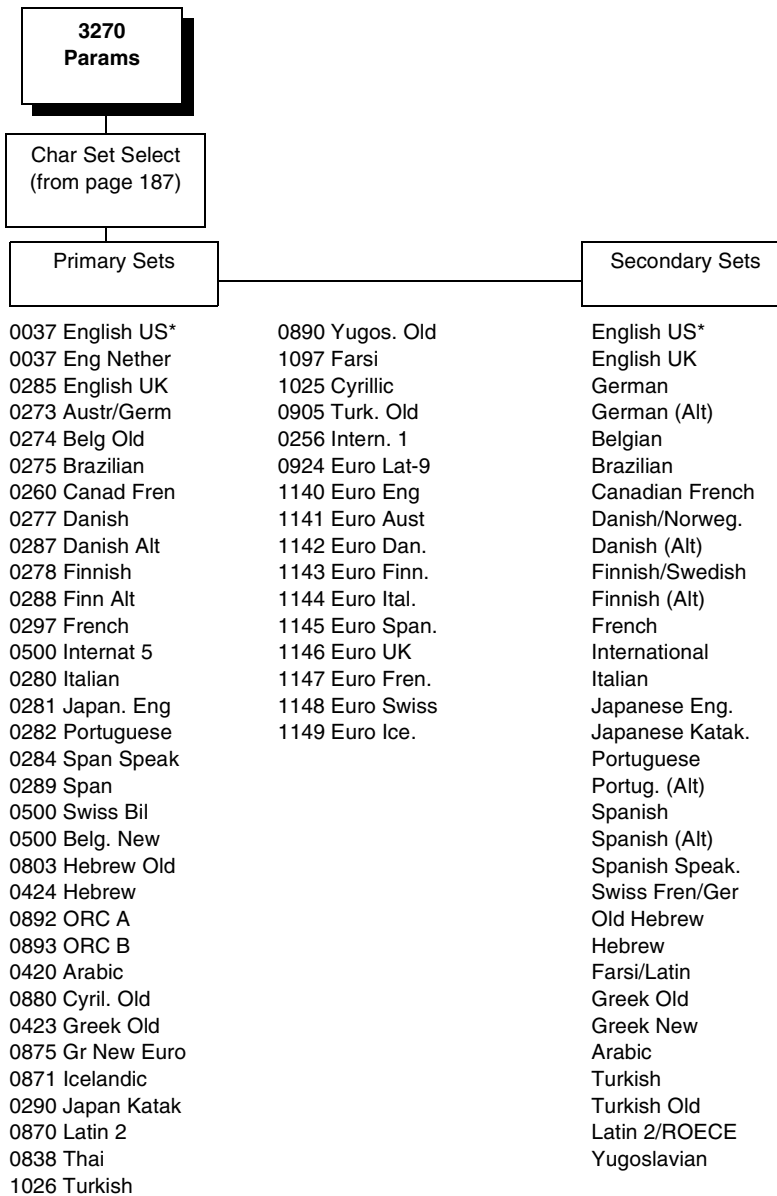

Translation Tbl

Prints out a table of the Coax interface's current character set. This operation is valid only when the TN3270 interface is the current interface.

Active Char Set

Specifies which character language set will be the active set.

- **Primary Sets** (default)
- **Secondary Sets**

Prt Partial Line

- **Enable** (default). When this option is enabled, it forces the printer to print if a partial line is in the printer (i.e. line not ending with a LF).
- **Disable**. When disabled, the last partial line of data will not be printed.

Early Print Cmpl

Early Print Complete allows the printer to send Print Complete status to the host before the printer is actually done printing all data. Early Print Complete is only available if the IPDS feature is installed.

- **Disable** (default). Means the printer will suppress the Early Print Complete response until all printing is complete.
- **Enable**. Means the printer will send an acknowledgement to the host when it is able to accept more data.

NOTE: When an Early Print Complete is enabled and an error occurs, the data in the printer will remain in the buffer (regardless of the setting of the Cancel Buffer option). It is recommended that local procedures be followed to recover from the error.

Do not select Early Print Complete while a print job is in progress. If this is done you will need to restart the printer.

PTX Transparent

Lead-in Chars

You can enable additional printer features which are not accessible through standard TN3270 emulations. To access these features, send text commands in the data stream. The commands must have a start and end code. Four sets are available:

- **Set 1.** start code: <% (default)
stop code: >
- **Set 2.** start code: ␣␣
stop code: \$
- **Set 3.** start code: _%
stop code: _
- **User Defined.**

Usr Defined HTRN

This option is used to set user defined lead-in characters. The range is ASCII character. This option allows users to define their own lead-in characters for the Printronix Specific commands. Select a hex value for the following codes for the User Defined option:

- **Start Code 1 5F** (default)
- **Start Code 2 5F**
- **Stop Code 5B**

Alt. Set 80-9F

- **Printable** (default). Prints data in the range of hex 80 through hex 9F.
- **Control Code.** Interprets data in the range of hex 80 through hex 9F as a control code.

Change Case

Specifies the font as Mono or Dual case. This option is available only in non-SCS mode. The host will be notified of the change when the printer is placed online. Mono Case prints the same as Dual Case if the character set is one of the following “right to left” sets: Katak., Hebrew, Old Hebrew, and Farsi.

SCS (System Network Architecture Character String) mode is controlled by the host computer.

- **Dual Case** (default)
- **Mono Case**

Set Text Orientn

Specifies the direction in which characters are printed on the page. This allows the printer to print languages which are printed right to left instead of left to right.

- **Left to Right** (default).
- **Right to Left.** When a right to left language is selected, the host will be notified of print direction changes when the printer is put online.

Intervention Req

Select from the following:

- **Not Send To Host**
- **Send To Host** (default). The printer sends a signal to the host computer when any of the following occur:
 - Printer faults occur.
 - Hold mode time-out occurs.

If not selected, the printer will only send the signal on printer faults that cause data loss (paper jam, ribbon stall, online platen open, etc.).

Compatibility Op

The Compatibility Options allow you to select special printer functions in the non-SCS mode based on the capabilities of the printer emulated.

CR At MPP+1

MPP is Maximum Print Position, which is also known as line length. This option controls a carriage return at the end of a print line and at MPP+1.

- **On** (default). Produces a carriage return to the first print position of the next line.
- **Off**. Produces a carriage return to the first print position of the current line.

NL At MPP+1

Controls how many lines are skipped when the carriage returns to a new line.

- **On** (default). Moves to the first print position two lines down from the current position.
- **Off**. Moves to the first print position of the next print line.

Position Aft FF (4234 only)

Allows you to select the location of the print position after a form feed command is sent.

- **On** (default). Sets the printer to print at print position 1 of the first print line on the next form.
- **Off**. Sets the printer to print at print position 2 of the first print line on the next form.

Last Char = FF

Determines the print line position when a form feed command is the last code encountered in the print buffer.

- **On** (default). Moves to the first print position on the second line of the next form.
- **Off**. Moves to the first print position on the first line of the next form.

NOTE: This option is ignored if Auto Skip At End is on.

If configured as a 3287, and a form feed occurs in the middle of a print buffer, the printer defaults to the first print position on the second line of the next form regardless of the setting of this option.

Null Suppression

- **Off** (default). Ignores nulls. The print position does not move.
- **On**. Treats nulls as blank spaces.

FF Validity

Determines if the position of a form feed command affects its execution.

- **Off** (default). Performs a form feed only if it occurs at the first print position in a line or at Maximum Print Position +1. A form feed command at any other position is recognized as a space.
- **On**. Allows the printer to perform a form feed command anywhere in the data stream.

Chapter 4 Coax/Twinax (CTHI) Emulation

Auto Skip At End

Specifies whether or not to perform an automatic form feed at the end of a print buffer. If form feed is the last character in the print order, the form feed function is supplied by the Auto Skip At End option.

- **Off** (default). Sets the printer to print at print position 1 of the next line.
- **On**. Sets the printer to print at print position 1 of the first line of the next form.

FF After Job

Determines the print position after an operator-initiated local copy (print screen function).

- **Off** (default). Performs an automatic new line command after completing a print buffer (unless a new line, form feed, or carriage return command was the last one executed). The printer is set to print at print position 1 of the next line.
- **On**. Performs an automatic form feed command unless a form feed was the last one executed. The printer is set to print at print position 1 of the first line on the next form.

CR, EM, and NL (3287 only)

CR (Carriage Return), EM (Error Message), and NL (New Line) specify that the printer treat the CR, EM, and NL control codes either as spaces or as control codes.

- **On** (default). Treats the CR, EM, and NL commands as control codes.
- **Off**. Treats the CR, EM, and NL commands as spaces.

Host Override

Determines whether the printer accepts certain commands sent by the host, or continues to use the current operator panel settings.

- **Disable** (default). Allows these host commands to override operator panel settings: line length, forms length, lines per inch (LPI), characters per inch (CPI), print quality, and text orientation. Note the information appearing on the message display may not match the data stream setting. No values will change upon initial selection of the disable option.
- **Enable**. The operator panel settings override the host commands.

Format Control

Enables the printer to reflect the same spacing as CTPC model printers after absolute and relative move commands are executed.

- **Disable** (default). Reflects distance, generated by the VGL feature, PGL feature, and Hex Transparent control code sequence, in the new position (after horizontal and vertical tabs are executed).
- **Enable**.

Max. Print Width

Set the maximum print width the printer will print when using a C/T host interface. Set for 13.2 inches when printing files larger than the width of the printer. All data exceeding the width of the maximum Printer Width will be truncated.

- **13.2 inches** (default)
- **Printer Width** (the maximum width of the printer)

Chapter 4 Coax/Twinax (CTHI) Emulation

5250 Params

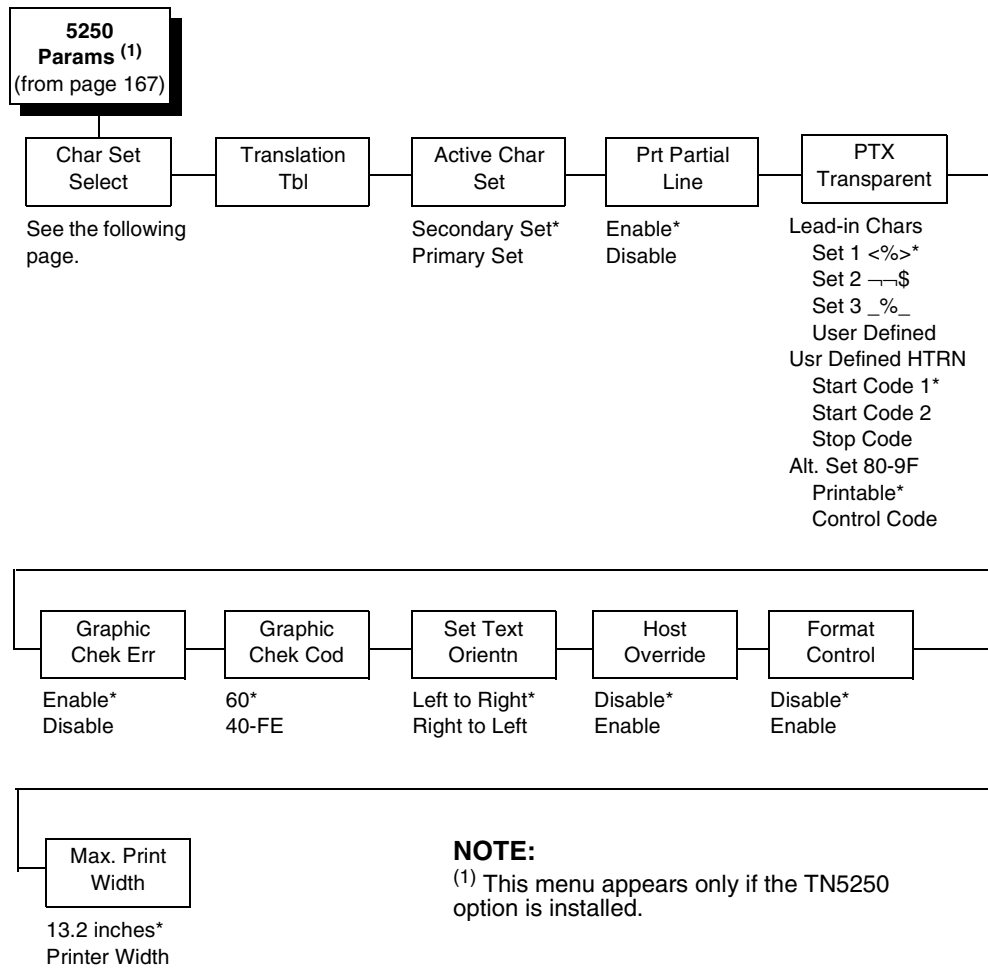

* = Factory Default

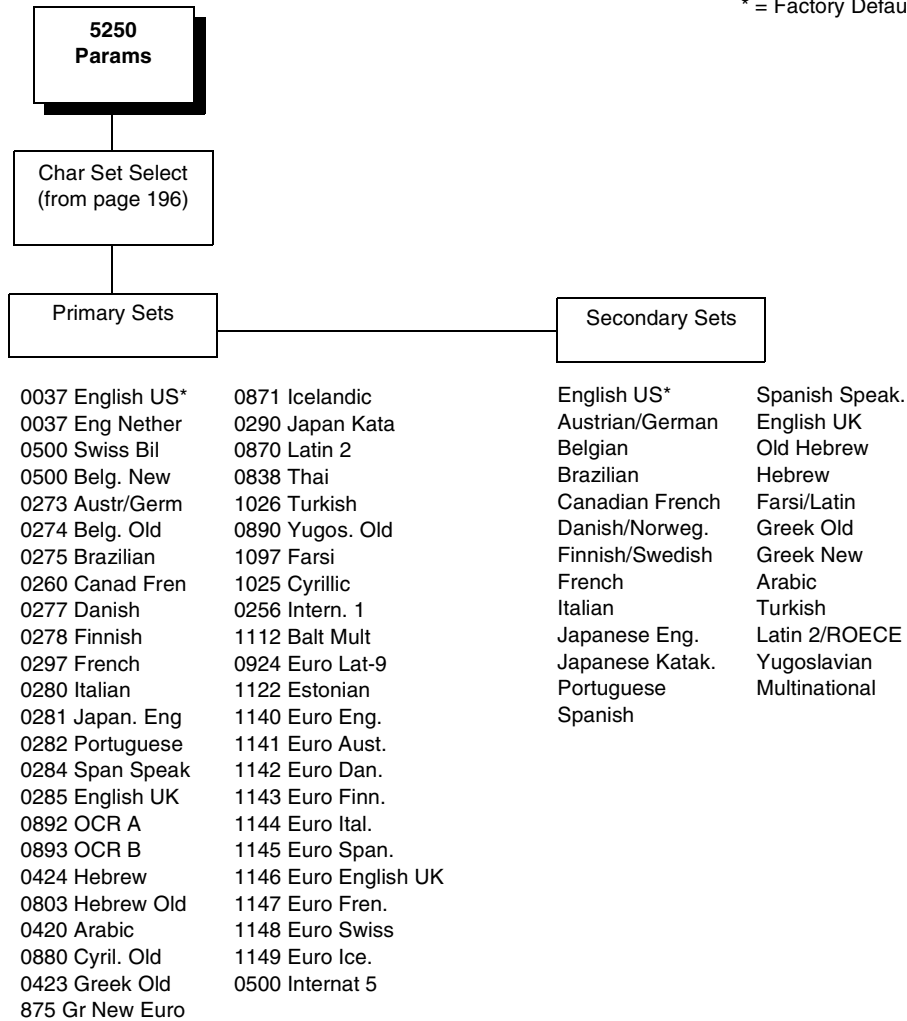

Translation Tbl

Prints out a table of the TN5250 interface's current character set. This operation is valid only when the TN5250 interface is the current interface.

Active Char Set

Selects which group of character sets (Primary or Secondary) will be active.

- **Secondary Set** (default)
- **Primary Set**

Prt Partial Line

- **Enable** (default). When this option is enabled, it forces the printer to print if a partial line is in the printer (i.e. line not ending with a LF).
- **Disable**. When disabled, the last partial line of data will not be printed.

PTX Transparent

Lead-in Chars

You can enable additional printer features which are not accessible through standard TN5250 emulations. To access these features, send text commands in the data stream. The commands must have a start and end code. Four sets are available:

- **Set 1.** start code: <% (default)
stop code: >
- **Set 2.** start code: ─┐
stop code: \$
- **Set 3.** start code: _%
stop code: _
- **User Defined.**

Usr Defined HTRN

This option is used to set user defined lead-in characters. The range is ASCII character. This option allows users to define their own lead-in characters for the Printronix Specific commands. Select a hex value for the following codes for the User Defined option:

- **Start Code 1 5F** (default)
- **Start Code 2 5F**
- **Stop Code 5B**

Alt. Set 80-9F

- **Printable** (default). Prints data in the range of hex 80 through hex 9F.
- **Control Code**. Interprets data in the range of hex 80 through hex 9F as a control code.

Graphic Chek Err

Allows overriding of the host setting for the SGEA (Set Graphic Error Action) command. For more information about the SGEA command, refer to the *Coax/Twinax Programmer's Reference Manual*.

- **Enable** (default). The host setting for the SGEA used by the printer. If the SGEA command is requested to stop on graphic errors, the printer will stop when a graphic error is detected.
- **Disable**. Ignores the SGEA command from the host. The printer does not stop when an error is detected; instead, it substitutes the character selected in the Graphic Chek Code parameter.

Graphic Chek Cod

Specifies the replacement character to print in place of any unprintable character that is received from the host. Choose a hex character from 40 through FE. The character becomes the printer default when:

- The printer is powered off and then powered on.
- An SGEA command specifies to use the operator panel default.
- The Graphic Chek Err parameter is disabled.

The value can be the following:

- **60** (default)
- **40 – F4**

Set Text Orientn

Specifies the direction in which characters are printed on the page. This allows the printer to print languages which are printed right to left instead of left to right.

- **Left to Right** (default)
- **Right to Left**. When a right to left language is selected, the host will be notified of print direction changes when the printer is put online.

Host Override

Determines whether the printer accepts certain commands sent by the host, or continues to use the current operator panel settings.

- **Disable** (default). Allows these host commands to override operator panel settings: line length, forms length, lines per inch (LPI), characters per inch (CPI), print quality, and text orientation. Note the information appearing on the message display may not match the data stream setting. No values will change upon initial selection of the disable option.
- **Enable**. The operator panel settings override the host commands.

Format Control

Enables the printer to reflect the same spacing as CTPC model printers after absolute and relative move commands are executed.

- **Disable** (default). Reflects distance, generated by the VGL feature, PGL feature, and Hex Transparent control code sequence, in the new position (after horizontal and vertical tabs are executed).
- **Enable**.

Max. Print Width

Set the maximum print width the printer will print when using a C/T host interface. Set for 13.2 inches when printing files larger than the width of the printer. All data exceeding the width of the maximum Printer Width will be truncated.

- **13.2 Inches** (default)
- **Printer Width** (the maximum width of the printer)

SPC Coax Params

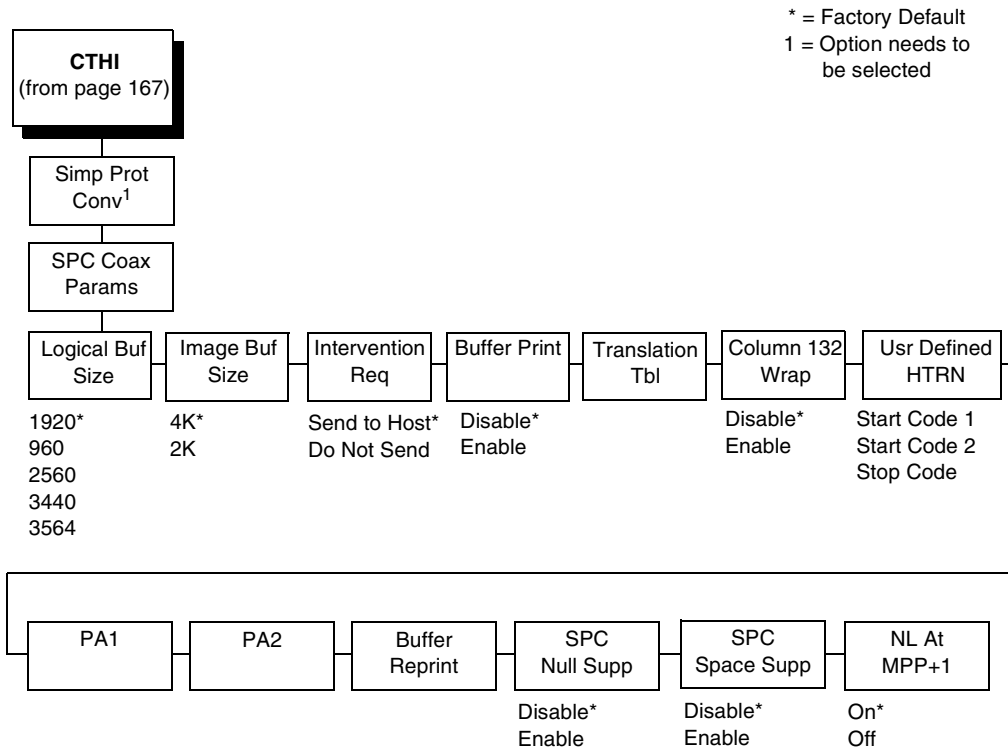

Logical Buf Size

Refers to the size of the printer buffer, which should be set the same as the host screen (buffer) size. If the host screen size is unknown, use 1920. Do not change this parameter in the middle of a print job.

Image Buf Size

This option refers to the printer base buffer size. This size must be set to a value greater than or equal to the Logical Buffer Size.

Intervention Req

- **Send to Host** (default). The printer sends a signal to the host computer when the CANCEL key is pressed or a printer fault or hold mode time-out occurs.
- **Do Not Send**. No signal will be sent to the host computer.

Buffer Print

- **Disable** (default). The printer will print normally.
- **Enable**. The printer prints the EBCDIC data and control codes received from the host as hex values. Refer to page 315 for information on how to obtain a hex code printout.

Translation Tbl

Prints a table of the Coax interface's current character set. This operation is valid only when the Coax interface is selected (see "HOST INTERFACE" on page 85).

Column 132 Wrap

When enabled, this option causes the printer to line wrap at 132 characters despite the current print density, allowing more characters per line. The options include:

- **Disable** (default)
- **Enable**

Usr Defined HTRN

This option is used in Twinax SPC emulation. The range is ASCII character. This option allows users to define their own lead-in characters for the Printronix Specific commands. Select a hex value for the following codes for the User Defined option:

- **Start Code 1 5F**
- **Start Code 2 5F**
- **Stop Code 5B**

PA1

PA1 is only valid when the printer is in the offline state and the Coax Systems Network Architecture Character String (SCS) data stream is active. This function displays the “PA1 ENABLED” message when the ENTER key is pressed and sends a special operator request to the host when the printer is placed online. Refer to the *Coax/Twinax Programmer's Reference Manual* for more information about SCS.

PA2

PA2 is only valid when the printer is in the OFFLINE state and the Coax SCS data stream is active. This function displays the “PA2 ENABLED” message when the ENTER key is pressed and sends a special operator request to the host when the printer is placed ONLINE.

Buffer Reprint

This option is valid only when the printer is printing in SCS mode. When the ENTER key is pressed, “Buffer Reprint Enabled” is displayed and an Intervention Required status is sent to the host. Pressing ENTER again cancels the Buffer Reprint function and “Buffer Reprint Disabled” is displayed.

SPC Null Supp

- **Disable** (default). Ignores nulls. The print position does not move.
- **Enable**. Treats nulls as blank spaces.

SPC Space Supp

This option is only available in Coax SPC emulation and is used in LU3/DSC/DSE mode only.

- **Disable** (default). Treats nulls and spaces normally.
- **Enable**. If the entire line consists of spaces and nulls, the line will be discarded.

NL At MPP+1

Controls how many lines are skipped when the carriage returns to a new line.

- **On** (default). Moves to the first print position two lines down from the current position.
- **Off**. Moves to the first print position of the next print line.

Chapter 4 Coax/Twinax (CTHI) Emulation

SPC Twx Params

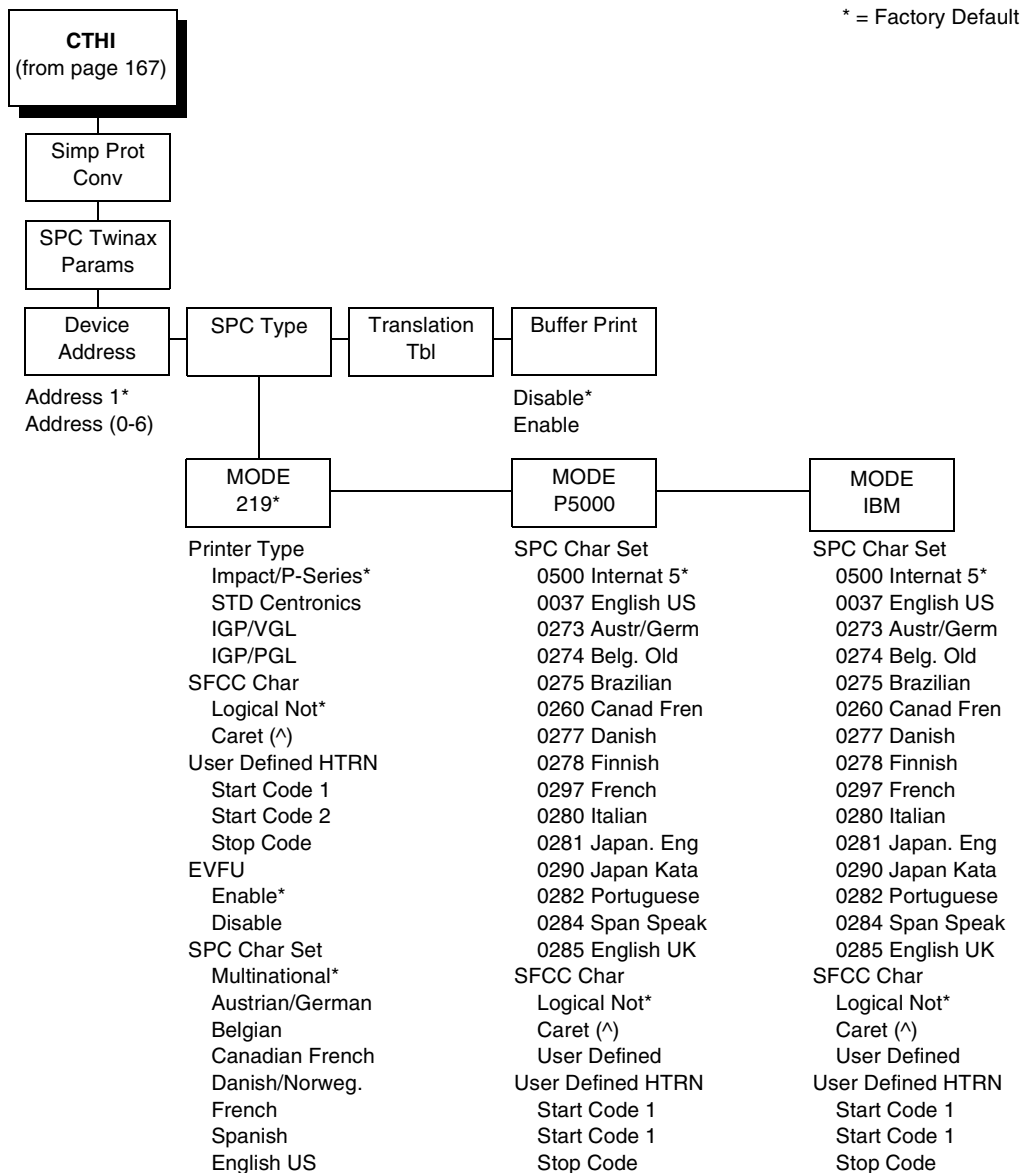

NOTE: To access the SPC Twinax Params menu, be sure to select the Twinax option in the Host Interface menu.

Device Address

Allows you to set the device address from 0 through 6. The host directs data and commands on the twinax line to a specific device based on its unique device address. After the address has been changed, a POR status is sent to the host.

SPC Type

Allows you to select a specific type of Simple Protocol Convertor (SPC) Twinax emulation: MODE 219 for Model 219 protocol convertor, MODE P5000 for Printronix protocol convertor, and MODE IBM for the IBM protocol convertor.

Printer Type

Determines the SPC Twinax emulation "Mode." When set to Std Centronics, IGP/VGL, or IGP/PGL, the Set Line Density and Set Print Density commands are translated into a Carriage Return (CR), and vertical format commands are ignored unless the EVFU is enabled.

SFCC Char

Determines what character is printed when an EBCDIC Logical Not character ¬ (Hex 5F) is received from the host.

User Defined HTRN

This option is used in Twinax SPC emulation. The range is ASCII character. This option allows users to define their own lead-in characters for the Printronix Specific commands. Select a hex value for the following codes for the User Defined option:

- **Start Code 1**
- **Start Code 2**
- **Stop Code**

Chapter 4 Coax/Twinax (CTHI) Emulation

EVFU

- **Enable.** The EVFU parameter allows vertical format control by the host in all four printer type modes.
- **Disable.** Vertical format control is only allowed in IMPACT/P-SERIES mode.

SPC Char Set

Allows you to select the print language character set.

Translation Tbl

Prints out a table of the Twinax interface's current character set. This operation is valid only when the Twinax interface is selected.

Buffer Print

- **Disable** (default). The printer will print normally.
- **Enable.** The printer prints the EBCDIC data and control codes received from the host as hex values. Refer to page 315 for information on how to obtain a hex code printout.

LinePrinter Plus Emulation

NOTE: When the printer is set to SPC Twx Params or SPC Coax Params, no LP+ menu items will take effect on the same offline. The LP+ Emulation resets when the printer is taken offline.

* = Factory Default

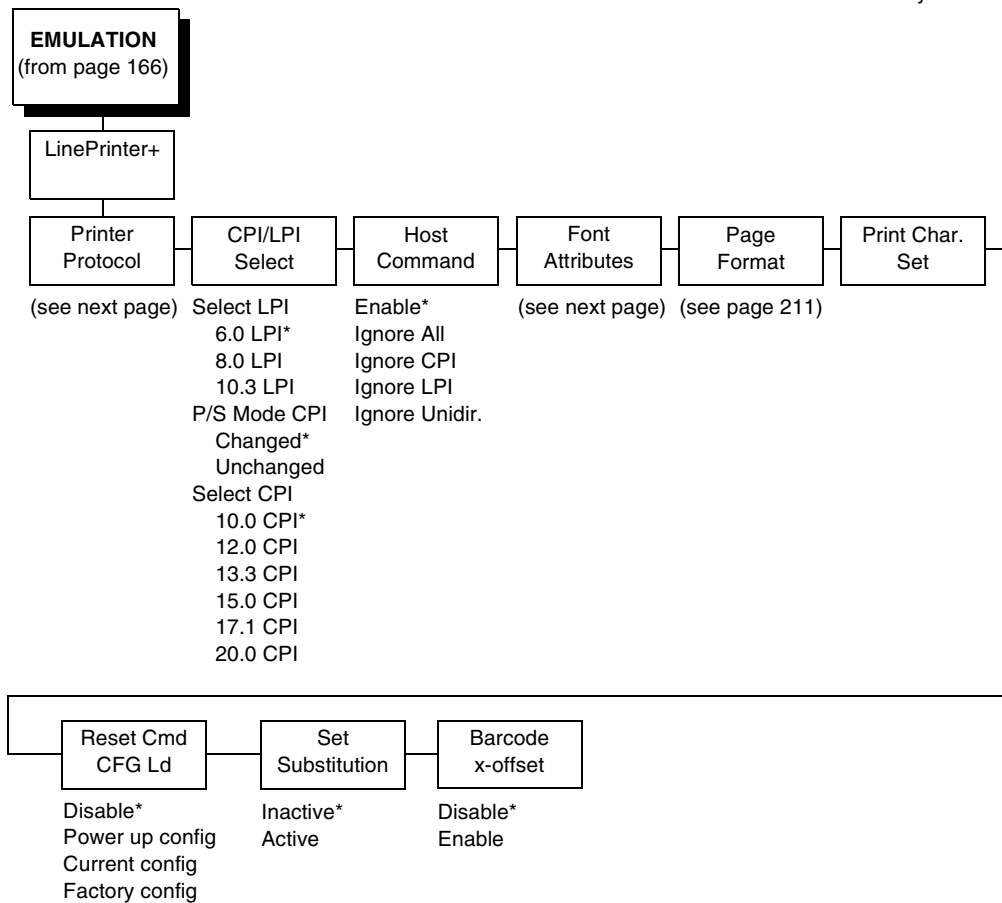

Chapter 4 LinePrinter Plus Emulation

* = Factory Default

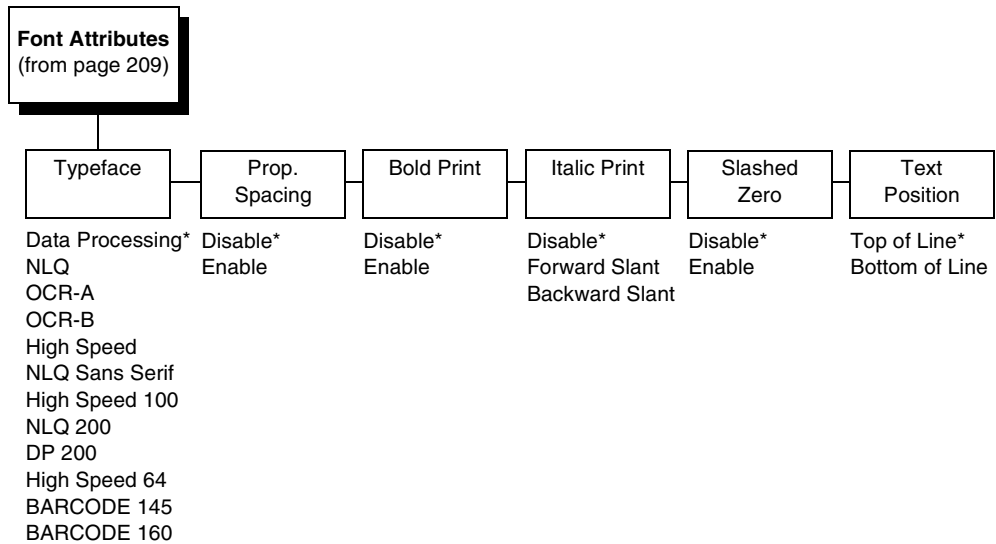
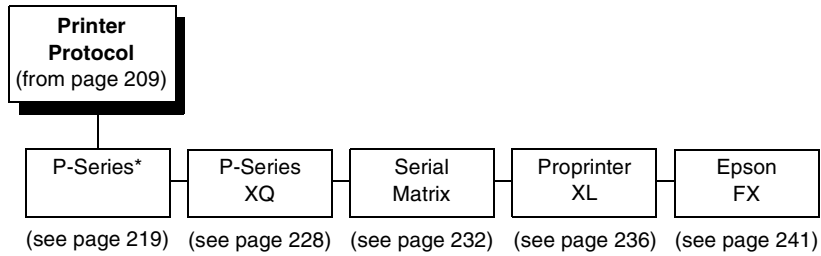

LinePrinter Plus Emulation

* = Factory Default
¹These menus do not appear if the Coax or Twinax host interface is selected. See page 85.
² This value is 132 if the Coax or Twinax host interface is selected.

Page Format (from page 209)

Form Length	Form Width	Margins	Perforation Skip ¹
Abs. Length IN ¹ 11.0* inches (0.1-24)	Abs. Width IN ¹ 13.6* inches (0.1-13.6)	Left Margin ¹ 0* columns (0-369)	Disable* 1/2 Inch
Abs. Length MM ¹ 279.4* mm (0.1-609.6)	Abs. Width MM ¹ 345.4* mm (0.1-345.4)	Right Margin ¹ 0* columns (0-369)	2/3 Inch
Funct. of Lines 66* lines (1-192)	Function of CPI 136 ^{*2} characters (1-272)	Bottom Margin 0* lines (0-451)	5/6 Inch
			1 inch

Chapter 4 LinePrinter Plus Emulation (with PCL-II)

LinePrinter Plus Emulation (with PCL-II)

NOTE: When the printer is set to SPC Twx Params or SPC Coax Params, no LP+ menu items will take effect on the same offline. The LP+ Emulation resets when the printer is taken offline.

* = Factory Default

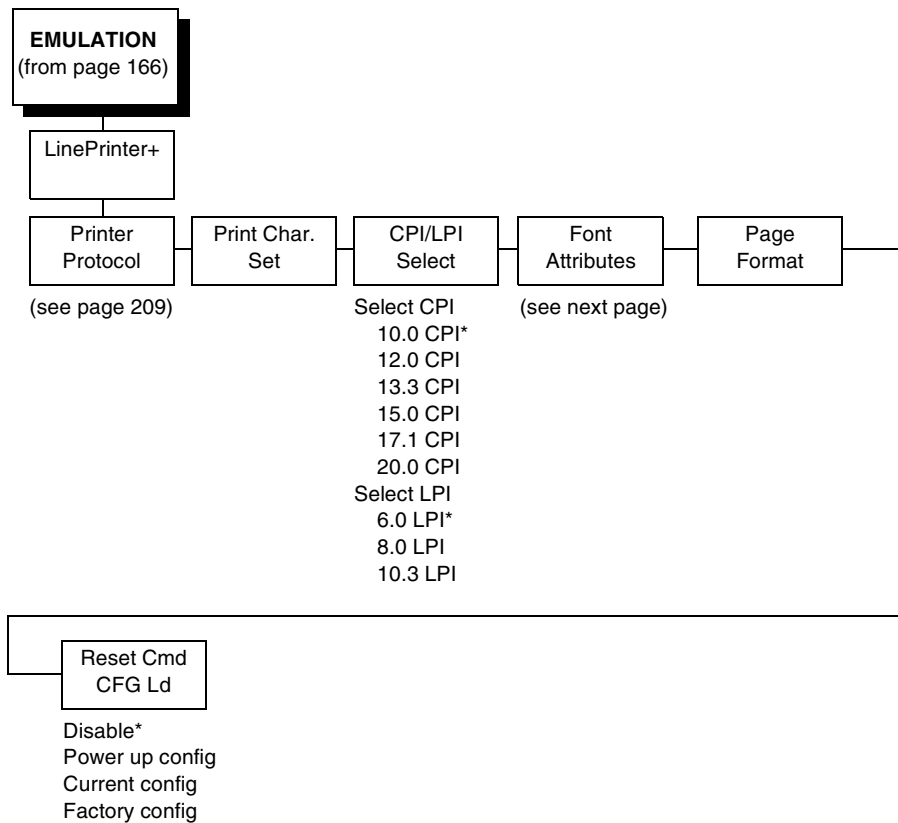

LinePrinter Plus Emulation (with PCL-II)

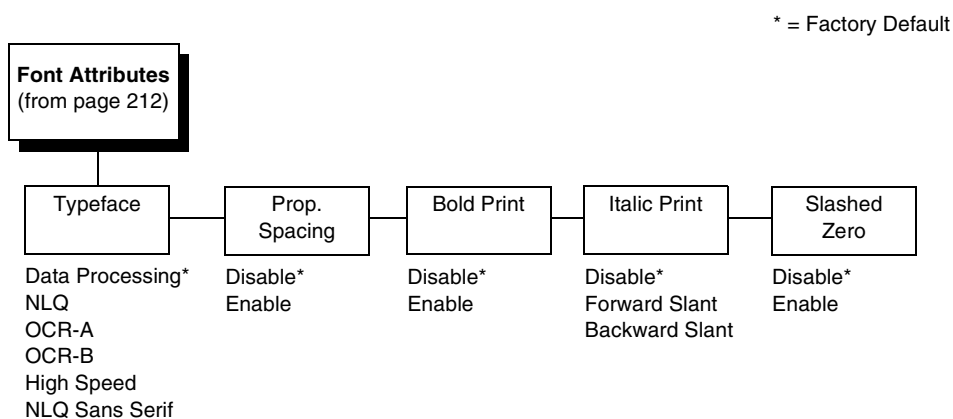

Printer Protocol

Select the LinePrinter+ protocol you wish to use. Refer to the *LinePrinter Plus Programmer's Reference Manual* for more information.

CPI/LPI Select

This parameter lets you specify the characters per inch (cpi) and lines per inch (lpi) values.

Host Command

This parameter allows you to block certain host commands from being acknowledged by the printer.

- **Enable** (default). All host commands are acknowledged by the printer.
- **Ignore All**. All host commands are ignored by the printer.
- **Ignore CPI**. All CPI commands sent by the host are ignored by the printer.

- **Ignore LPI.** All LPI commands sent by the host are ignored by the printer.
- **Ignore Unidir.** All Unidirectional commands sent by the host are ignored by the printer.

Font Attributes

Typeface

- **Data Processing.** A general purpose font printing out at 120 dpi horizontally and 72 dpi vertically. The width of the font will vary with each cpi.
- **NLQ.** A high quality font printing at 180 dpi horizontally and 96 dpi vertically. This font has serifs and the width of the font varies with the cpi.
- **OCR-A / OCR-B.** Optical character recognition fonts printing at 120 dpi horizontally and 144 dpi vertically. Both fonts print only at 10 cpi.
- **High Speed.** A draft quality font printing at 120 dpi horizontally and 48 dpi vertically. The width of the font varies with the cpi.
- **NLQ Sans Serif.** A high quality font printing at 180 dpi horizontally and 96 dpi vertically. This font prints without serifs. The width of the font varies with the cpi.
- **High Speed 100.** A draft quality font printing at 100 dpi horizontally and 48 dpi vertically. When chosen from the front panel, it defaults to 10 cpi. The cpi can then be varied, but the width will not change.
- **NLQ 200.** This NLQ font prints at 200 dpi horizontally and 96 vertically. When chosen from the front panel, it defaults to 12 cpi. The cpi can then be varied, but the width will not change.
- **DP 200.** This Data Processing font prints at 200 dpi horizontally and 72 vertically. When chosen from the front panel, it defaults to 12 cpi. The cpi can then be varied, but the width will not change.

- **High Speed 64.** This font prints at 120 dpi horizontally and 64 vertically. When chosen from the front panel, it defaults to 10 cpi. The cpi can then be varied, but the width will not change.
- **BARCODE 145.** This Data Processing font prints at 145 dpi horizontally and 72 vertically. When chosen from the front panel, it defaults to 12 cpi. The cpi can then be varied, but the width will not change.
- **BARCODE 160.** This Data Processing font prints at 160 dpi horizontally and 72 vertically. When chosen from the front panel, it defaults to 13 cpi. The cpi can then be varied, but the width will not change.

Prop. Spacing (Proportional Spacing)

Each printed character is contained inside a character cell. The width of the character cell includes the character and the space around the character.

- **Disable.** Each character cell is printed with the same width. Each column in the printed text will line up.

```
This example is printed with  
proportional spacing disabled.
```

- **Enable.** The width of each character cell varies with the width of the character. For example, [i] takes less space to print than [m]. Using proportional fonts generally increases the readability of printed documents, which gives text a typeset appearance.

```
This example is printed with  
proportional spacing enabled.
```

Chapter 4 LinePrinter Plus Emulation (with PCL-II)

Bold Print

- **Disable.** Text is printed normally.
- **Enable.** Text is printed with a heavy line thickness.

Italic Print

- **Disable.** Text is printed normally.
- **Forward Slant.** Text is printed with a forward slant.
- **Backward Slant.** Text is printed with a backward slant.

Slashed Zero

This parameter allows you to print the numeral “0” with or without the slash. This option applies to all character sets except OCR-A and OCR-B.

- **Disable.** Zero is printed without a slash.
- **Enable.** Zero is printed with a slash.

Text Position

Specifies where the text will be positioned in the line space. When set to Top-of-Line, text will be positioned at the top of the line space. When set to Bottom-of-Line, the text will be positioned as if it were at the bottom of a 6 lpi line space. The following example shows both Top-of-Line and Bottom-of-Line text positions:

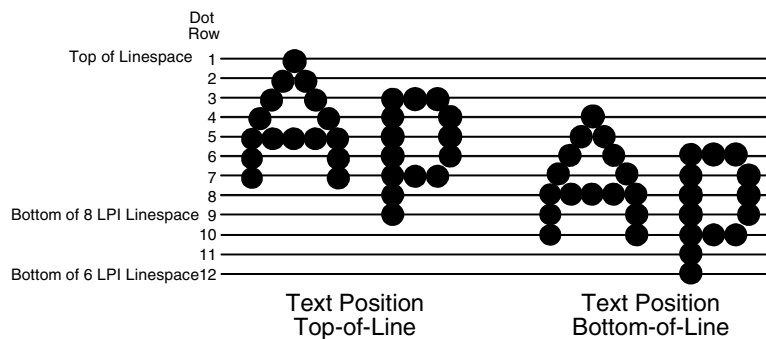

Page Format

Form Length

Form length is the number of lines that can be printed on a page. You can set the form length in inches, millimeters (mm), or as a function of the current lpi (lines per inch).

Form Width

The form width can be specified in inches, millimeters, or as a function of the current cpi (characters per inch). The form width set should not exceed the actual paper width.

Margins

- **Left Margin.** Set in columns. Column zero is defined as the far left edge of the page, and column numbering increments from left to right.
- **Right Margin.** Set in columns. Column zero is defined as the far right edge of the page, and column numbering increments from right to left.
- **Bottom Margin.** Defined in lines, starting from line zero at the bottom of the page and incrementing from the bottom up.

Perforation Skip

- **Disable.** Allows printing on page perforation.
- You may set up a skip-over margin of 1/2 inch, 2/3 inch, 5/6 inch, or 1 inch. For example, a skip-over margin of 1 inch allows a 1 inch margin at the bottom of the page.

Print Char. Set

When this selection is displayed and the ENTER key is pressed, the current character set is printed.

Reset Cmd CFG Ld

When the printer receives a host data stream reset command (ESC @ or ESC[K) in addition to resetting printer variables, the selected configuration is loaded.

- **Disable** (default). The active emulation parameters are loaded when the reset command is executed.
- **Power-Up Config**. The power-up configuration is loaded when the reset command is executed.
- **Current Config**. The currently selected configuration is loaded when the reset command is executed.
- **Factory Config**. The factory installed configuration is loaded when the reset command is executed.

Set Substitution

When this option is activated, the character set overlay in RAM is activated. This can also be accomplished through a host command of **SFCC RX**. In either case, a flag is set indicating that the substitution table is active. If the power-up configuration has Ld Set at Pwrup and Set Substitution both enabled, the character set overlay is automatically activated at power-up or during a soft reset. See the *LinePrinter Plus Programmer's Reference Manual* for more information.

Barcode X-Offset

- **Disable** (default)
- **Enable**. Allows text to print next to a barcode when xxxx and yyyy are not set to the origin.

P-Series Emulation

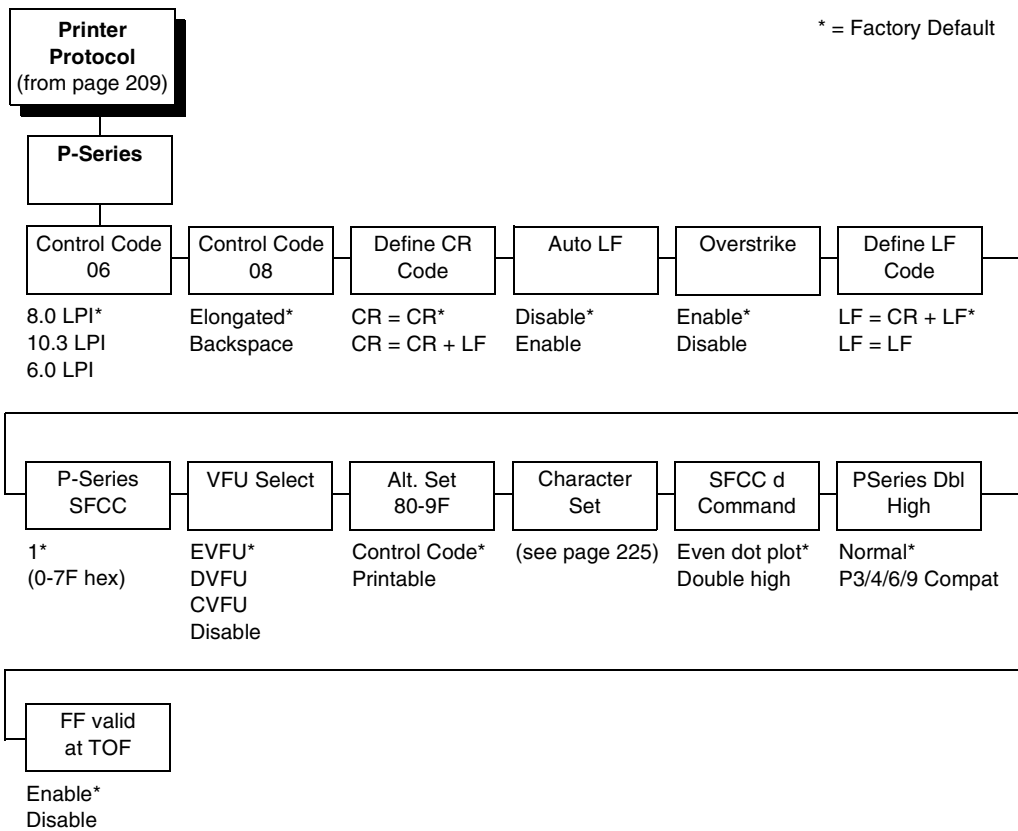

Chapter 4 LinePrinter Plus Emulation (with PCL-II)

P-Series Emulation (with PCL-II)

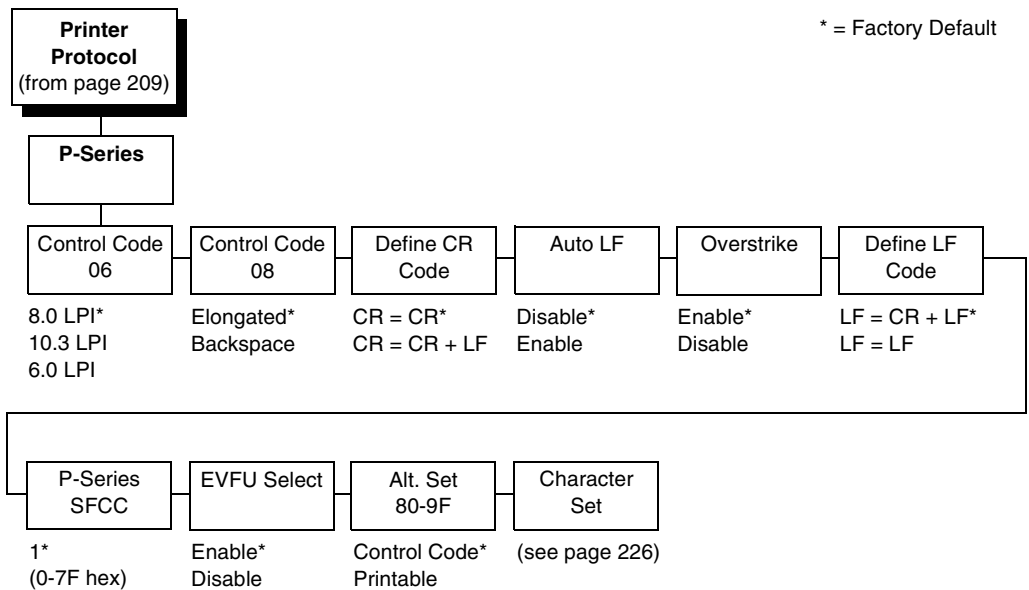

P-Series Emulation (with LG)

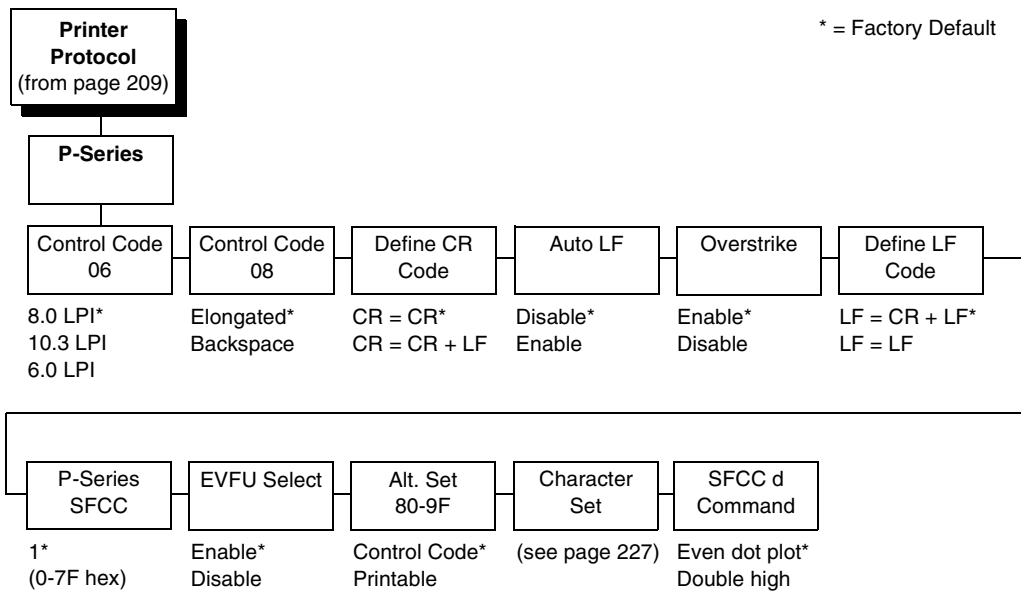

Control Code 06

Control Code 06 defines the function of ASCII code hex 06 (ACK). You can select an alternate line spacing of 6, 8, or 10.3 LPI.

Control Code 08

Control Code 08 defines the function of ASCII code hex 08 (BS). You can define the code to output the following character:

- **Elongated** (default).
- **Backspace**.

Define CR Code

This option controls the action of the printer when it receives a Carriage Return code (hex 0D) from the host computer. If this feature is enabled, each time the printer receives a carriage return, it inserts an additional Line Feed code (hex 0A) into the data stream. Do not use this feature if the host computer sends Line feeds to the printer.

- **CR = CR** (default). Does not insert an extra line feed after each carriage return.
- **CR = CR + LF**. Inserts an extra line feed after each carriage return. The next print position will be print position 1 of the next line.

Auto LF

This option defines the printer action when print data is received past the forms width setting.

- **Disable** (default). Discards any data past the forms width.
- **Enable**. Performs an automatic carriage return and line feed when data is received past the forms width, causing the excess text to print on the next line.

Overstrike

This option enables you to print bold characters.

- **Enable** (disable). Turns on bold print. When enabled, overstrike printing slows down the printer.
- **Disable**. Turns off bold print.

Define LF Code

- **LF = CR + LF** (default). Forces an automatic carriage return with each line feed command. The next print position is print position 1 of the next line.
- **LF = LF**. Does not perform an automatic carriage return. The next print position will be the current print position of the next line.

P-Series SFCC

This parameter allows you to select which ASCII codes will function as the Special Function Control Code (SFCC) command delimiter. P-Series codes can use hex 00 through hex 7F. Options include the following:

- ESC (hex 1B)
- SOH (hex 01)
- ETX (hex 03)
- CIRCUMFLEX (hex 5E)—also called caret (^)
- TILDE (hex 7E)—(~)

NOTE: SOH, ETX, and ESC are non-printables. The characters (^) and (~) are printable; however, do not use them as printables in the host data stream if either is chosen as a delimiter because print errors will occur.

VFU Select

Controls how the printer handles vertical formatting.

- **EVFU** (default). Enables the VFU and selects P-Series compatible Electronic Vertical Format Unit (EVFU).
- **DVFU**. Enables the VFU and selects the Dataproducts compatible Direct Access Vertical Format Unit (DVFU).
- **CVFU**. Enables the VFU and selects the Centronics compatible Direct Access Vertical Format Unit (CVFU).
- **Disable**. Disables all VFU processing.

Alt. Set 80-9F

Determines whether the printer processes ASCII codes hex 80 through hex 9F as control codes or as printable characters. The options include:

- **Control Code** (default)
- **Printable**.

Character Set

Specifies a character set as shown in the “P-Series Character Set Menu” on page 225. To use one of these sets, choose the desired group heading (such as European Sets) and press ENTER. Then choose the desired set within that group (such as Roman 8) and press ENTER. Both the group and the desired set will be starred to indicate your selection. Character sets are shown in detail in the *Character Sets Reference Manual*.

SFCC d Command

- **Even dot plot** (default). This option interprets SFCC d Command as even dot plot.
- **Double High**. This option interprets SFCC d Command as double high. Select this option for backward compatibility.

PSeries Dbl High

Allows printing compatibility between current and older model printers.

- **Normal** (default). This is normal, double-high printing for current model printers.
- **P3/4/6/9 Compat**. Where older printers print two dot rows higher, this option allows for compatibility by raising the print two dot rows to match the current models dot row value (two dot rows lower).

FF Valid at TOF

- **Enable** (default). Performs a form feed when the host sends a Form Feed command and the printer is at the top of form.
- **Disable**. Will not perform a form feed when the host sends a Form Feed command and the printer is at the top of form.

P-Series Character Set Menu

Character Set
(from page 219)

* = Factory Default

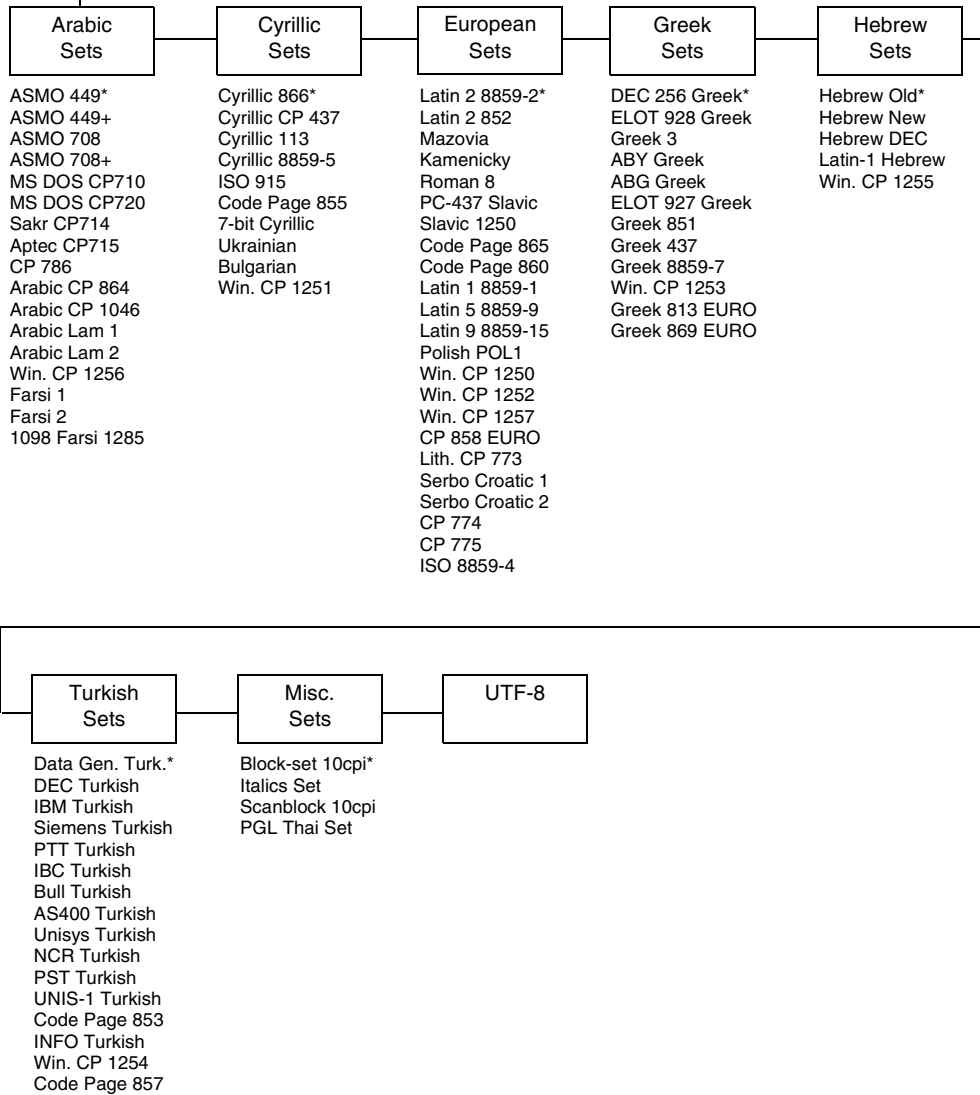

Chapter 4 LinePrinter Plus Emulation (with PCL-II)

P-Series Character Set Menu (with PCL-II)

* = Factory Default

Character Set
(from page 220)

IBM PC*
 Primary Subset
 ASCII (USA)*
 French
 German
 English
 Danish
 Swedish
 Italian
 Spanish
 Japanese
 French Canadian
 Latin American
 Danish II
 Spanish II
 Latin Am II
 Extended Subset
 Code Page 437
 Code Page 850
 Extended Subset
Multinational
ECMA Latin 1
DEC Mult.
OCR-A
OCR-B
Latin 2 8859-2
Latin 2 852
Bulgarian
Latin 9 8859-15
Polish POL1
DEC 256 Greek
ELOT 928 Greek
Greek 3
ABY Greek
ABG Greek
ELOT 927 Greek
Greek 437
Greek 8859-7
PC851 LtGk [12G]
Greek-7 [12N]
Greek-8 [8G]
Hebrew Old
Hebrew New
Hebrew DEC

P-Series Character Set Menu (with LG)

Character Set
(from page 220)

* = Factory Default

IBM PC*	DEC Mult.
Primary Subset	ASCII (USA)*
ASCII (USA)*	French
French	German
German	English
English	Norw./Danish
Danish	Swedish
Swedish	Italian
Italian	Spanish
Spanish	Japanese
Japanese	French Canadian
French Canadian	Dutch
Latin American	Finnish
Danish II	Swiss
Spanish II	OCR-A
Latin Am II	OCR-B
Extended Subset	Latin 2 8859-2
Code Page 437	Latin 2 852
Code Page 850	Bulgarian
Multinational	Latin 9 8859-15
ASCII (USA)*	CP 858 Euro
EBCDIC	
ECMA Latin 1	
Primary Subset	
ASCII (USA)*	
German	
Swedish	
Danish	
Norwegian	
Finnish	
English	
Dutch	
French	
Spanish	
Italian	
Turkish	
Japanese	
Extended Subset	
Multinational*	
Barcode 10 CPI	
Mult. DP 10 CPI	
Mult. DP 12 CPI	
Mult. LQ 10 CPI	
Greek DP 10 CPI	
Greek DP 12 CPI	
Greek LQ 10 CPI	
Grap. DP 10 CPI	
Grap. LQ 10 CPI	
Sci. DP 10 CPI	
Sci. DP 12 CPI	
Sci. LQ 10 CPI	

P-Series XQ Emulation

* = Factory Default

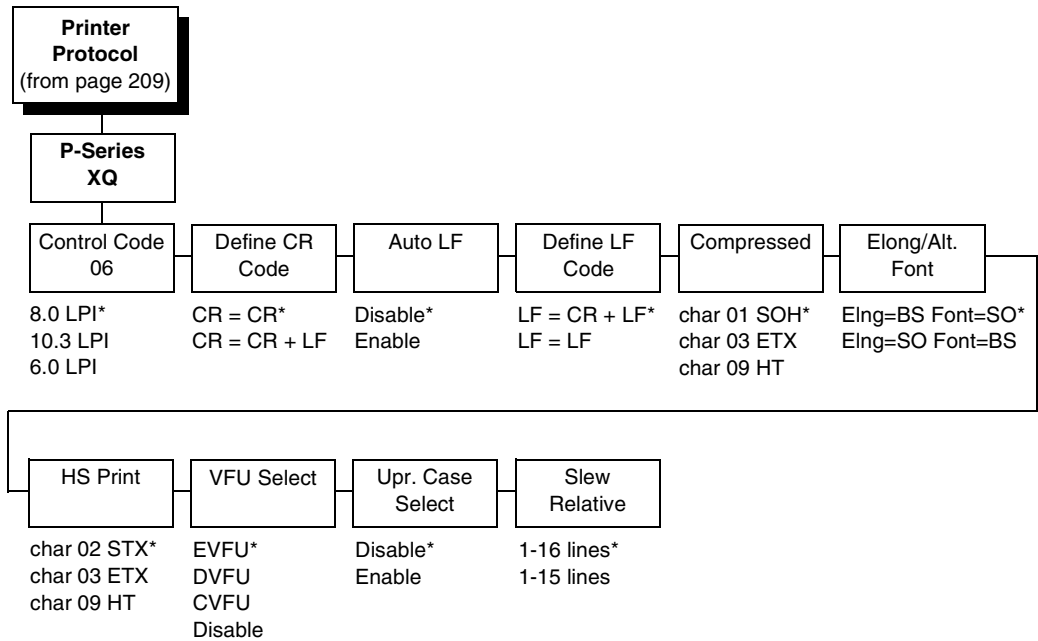

Control Code 06

Control Code 06 defines the function of ASCII code hex 06 (ACK). You can select an alternate line spacing of 6, 8, or 10.3 LPI.

Define CR Code

This option controls the action of the printer when it receives a Carriage Return code (hex 0D) from the host computer. If this feature is enabled, each time the printer receives a Carriage Return, it inserts an additional Line Feed code (hex 0A) into the data stream. Do not use this feature if the host computer sends line feeds to the printer.

- **CR = CR** (default). Does not insert an extra line feed after each carriage return.
- **CR = CR + LF**. Inserts an extra line feed after each carriage return. The next print position will be print position 1 of the next line.

Auto LF

This option defines the printer action when print data is received past the forms width setting.

- **Disable** (default). Discards any data past the forms width.
- **Enable**. Performs an automatic carriage return and line feed when data is received past the forms width.

Define LF Code

- **LF = CR + LF** (default). Forces an automatic carriage return with each line feed command received. The next print position is print position 1 of the next line.
- **LF = LF**. Does not perform an automatic carriage return when a line feed command is received. The next print position will be the current print position of the next line.

Compressed Print

Controls which host command sets compressed printing.

- **Char 01 SOH** (default)
- **Char 03 ETX**
- **Char 09 HT**

Elong/Alt. Font

Controls which host command sets elongated (double high) fonts and extended character set.

- **EIng=BS Font=SO** (default)
- **EIng=SO Font=BS**

HS Print (High Speed Print)

Controls which host command sets high speed printing.

- **Char 02 STX** (default)
- **Char 03 ETX**
- **Char 09 HT**

VFU Select

Controls how the printer handles vertical formatting. The choices are:

- **EVFU** (default). Enables the VFU and selects P-Series compatible Electronic Vertical Format Unit (EVFU).
- **DVFU**. Enables the VFU and selects the Dataproducts compatible Direct Access Vertical Format Unit (DVFU).
- **CVFU**. Enables the VFU and selects the Centronics compatible Direct Access Vertical Format Unit (CVFU).
- **Disable**. Disables all VFU processing.

Upr. Case Select

Controls how the printer handles lowercase characters it receives from the host computer. When enabled, all characters will be printed in uppercase.

- **Disable** (default). Prints lowercase characters received from the host computer as lowercase, and prints uppercase characters received from the computer as uppercase.
- **Enable**. Prints lowercase characters received from the host computer as their corresponding uppercase equivalents; uppercase characters received from the computer print as uppercase.

Slew Relative

“Slewing” is rapid vertical paper movement. This parameter determines the number of lines slewed (either 1-15 lines or 1-16 lines) when an EVFU Slew Relative command is received. The options include:

- **1-16 Lines** (default)
- **1-15 Lines**

Serial Matrix Emulation

* = Factory Default

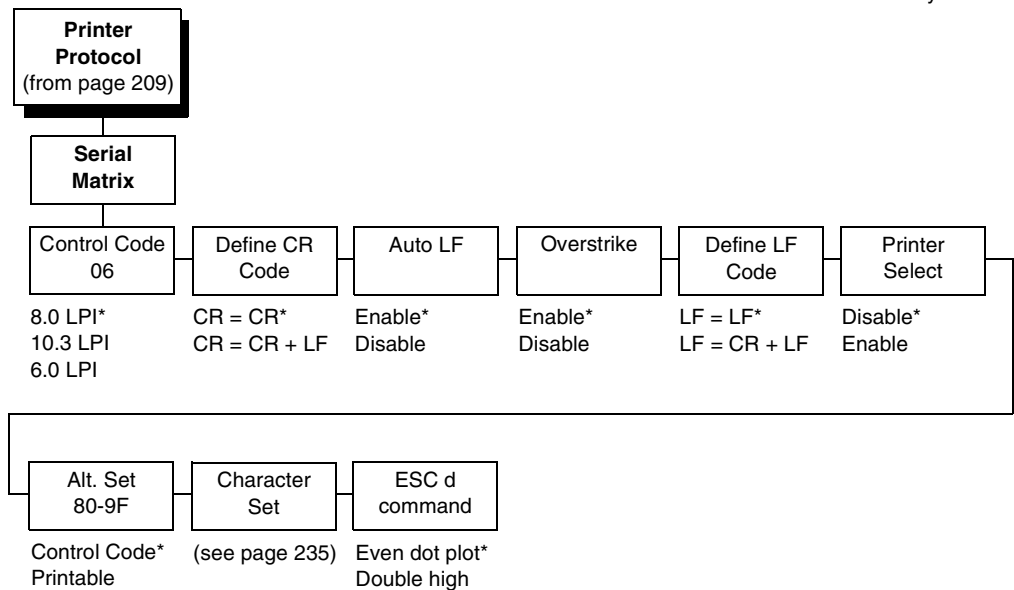

Control Code 06

Control Code 06 defines the function of ASCII code hex 06 (ACK). You can select an alternate line spacing of 6, 8, or 10.3 LPI.

Define CR Code

This option controls the action of the printer when it receives a Carriage Return code (hex 0D) from the host computer. If this feature is enabled, each time the printer receives a Carriage Return, it inserts an additional Line Feed code (hex 0A) into the data stream. Do not use this feature if the host computer sends line feeds to the printer.

- **CR = CR** (default). Does not insert an extra line feed after each carriage return.
- **CR = CR + LF**. Inserts an extra line feed after each carriage return. The next print position will be print position 1 of the next line.

Auto LF

The Auto LF option defines the printer action when print data is received past the forms width setting.

- **Enable** (default). Performs an automatic carriage return and line feed when data is received past the forms width.
- **Disable**. Discards any data past the forms width.

Overstrike

This option enables you to print bold characters.

- **Enable** (default). Turns on bold print. When enabled, overstrike printing slows down the printer.
- **Disable**. Turns off bold print.

Define LF Code

- **LF = LF** (default). Does not perform an automatic carriage return when a line feed command is received. The next print position will be the current print position of the next line.
- **LF = CR + LF**. Forces an automatic carriage return with each line feed command received. The next print position is print position 1 of the next line.

Printer Select

- **Disable** (default). Ignores the ASCII DC1 and DC3 control codes.
- **Enable**. Disables the printer when a DC1 control code is received, and enables the printer when a DC3 control code is received.

Alt. Set 80-9F

- **Control Code** (default). Interprets data in the range of hex 80 through hex 9F as a control code.
- **Printable**. Prints data in the range of hex 80 through hex 9F.

Character Set

Specifies a character set as shown in the “Serial Matrix Character Set Menu” on page 235. To use one of these sets, choose the desired group heading (such as European Sets) and press ENTER. Then choose the desired set within that group (such as Roman 8) and press ENTER. Both the group and the desired set will be starred to indicate your selection. Character sets are shown in detail in the *Character Sets Reference Manual*.

ESC d command

- **Even dot plot** (default). Interprets the ESC d command as even dot plot.
- **Double high**. Interprets the ESC d Command as double high. Select this option for backward compatibility.

Serial Matrix Character Set Menu

* = Factory Default

Character Set
(from page 232)

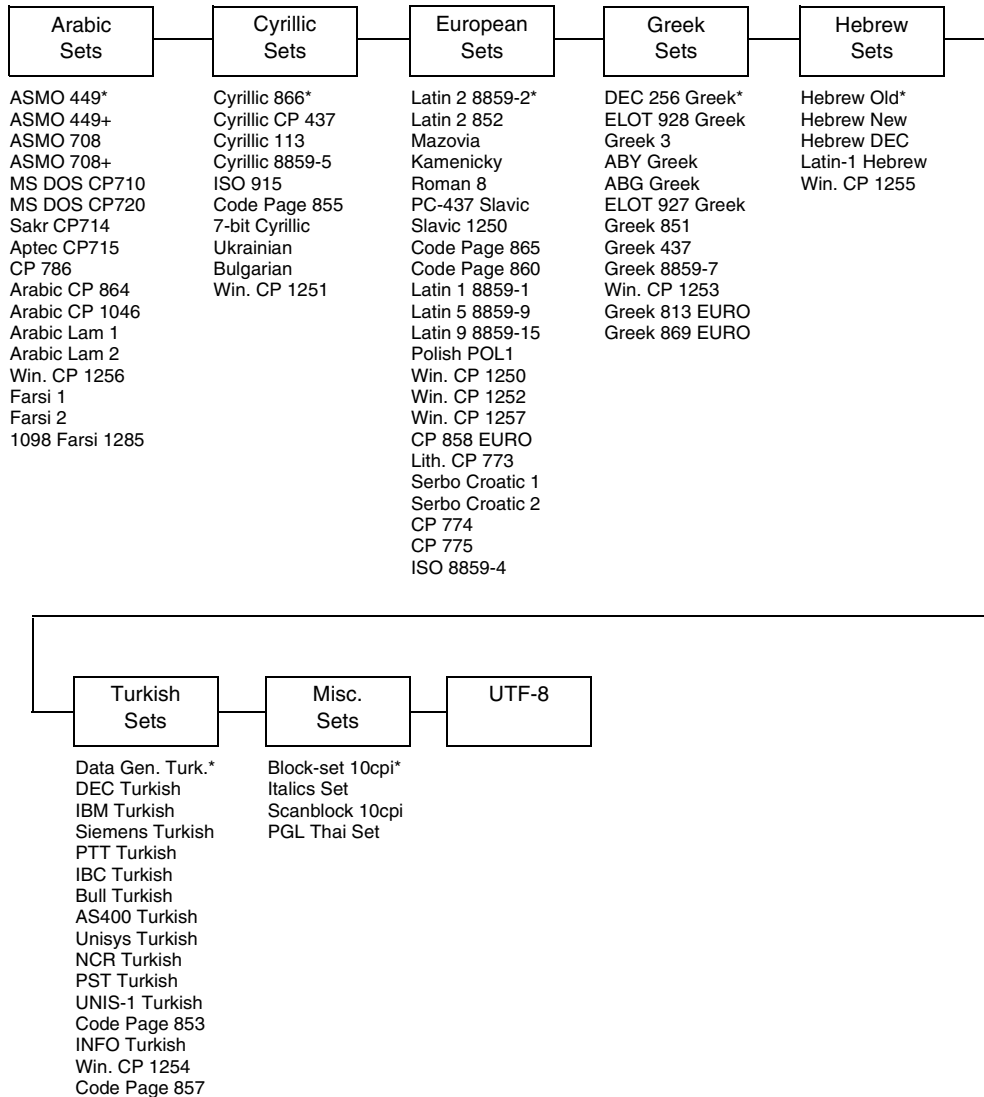

Proprinter XL Emulation

* = Factory Default

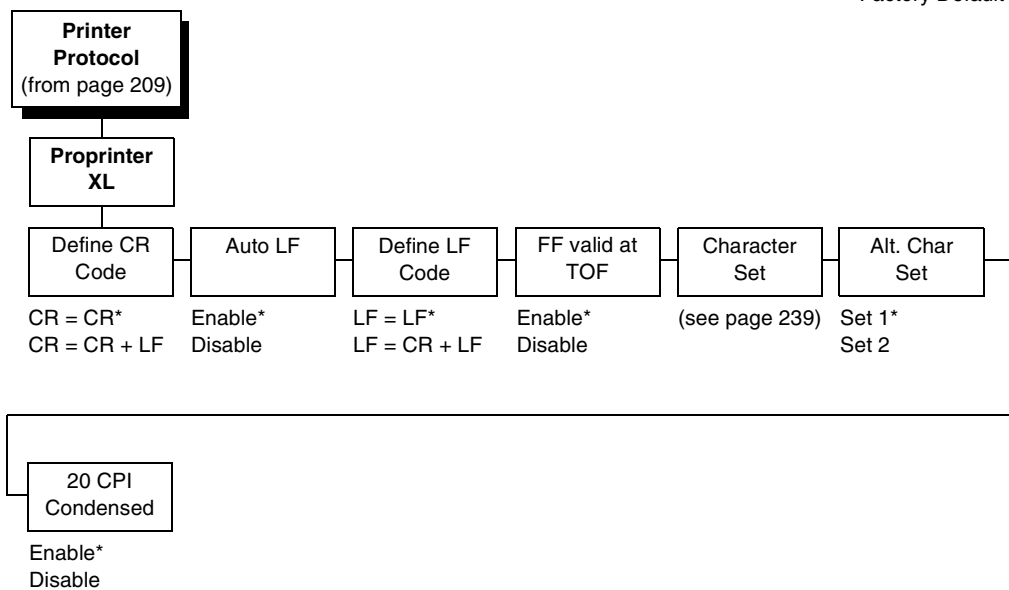

Define CR Code

This option controls the action of the printer when it receives a Carriage Return code (hex 0D) from the host computer. If this feature is enabled, each time the printer receives a Carriage Return, it inserts an additional Line Feed code (hex 0A) into the data stream. Do not use this feature if the host computer sends line feeds to the printer.

- **CR = CR** (default). Does not insert an extra line feed after each carriage return.
- **CR = CR + LF**. Inserts an extra line feed after each carriage return.

Auto LF

This option defines the printer action when print data is received past the forms width setting.

- **Enable** (default). Performs an automatic carriage return and line feed when data is received past the forms width.
- **Disable**. Discards any data past the forms width.

Define LF Code

- **LF = LF** (default). Does not perform an automatic carriage return when a Line Feed command is received. The next print position will be the current print position of the next line.
- **LF = CR + LF**. Forces an automatic carriage return with each Line Feed command received. The next print position is print position 1 of the next line.

FF Valid at TOF

- **Enable** (default). Performs a form feed when the host sends a Form Feed command and the printer is at the top of form.
- **Disable**. Will not perform a form feed when the host sends a Form Feed command and the printer is at the top of form.

Character Set

Specifies a character set as shown in the “Proprinter XL Character Set Menu” on page 239. To use one of these sets, choose the desired group heading (such as European Sets) and press ENTER. Then choose the desired set within that group (such as Roman 8) and press ENTER. Both the group and the desired set will be starred to indicate your selection. Character sets are shown in detail in the *Character Sets Reference Manual*.

Alt. Char Set

This option determines if data in the range of hex 80 through hex 9F should be interpreted as a control code or as a printable character.

- **Set 1** (default). Interprets data in the range of hex 80 through hex 9F as a control code.
- **Set 2**. Prints data for the characters at hex locations 03, 04, 05, 06, 15, and 80 through 9F.

20 CPI Condensed

Compressed print characters are narrower than the normal character set. This is helpful for applications where you need to print the maximum amount of information on a page.

- **Enable** (default). Prints characters about 60 percent the width of normal characters when compressed print is chosen by the host computer.
- **Disable**. Does not compress print widths, even if condensed print is chosen by the host.

Proprinter XL Character Set Menu

* = Factory Default

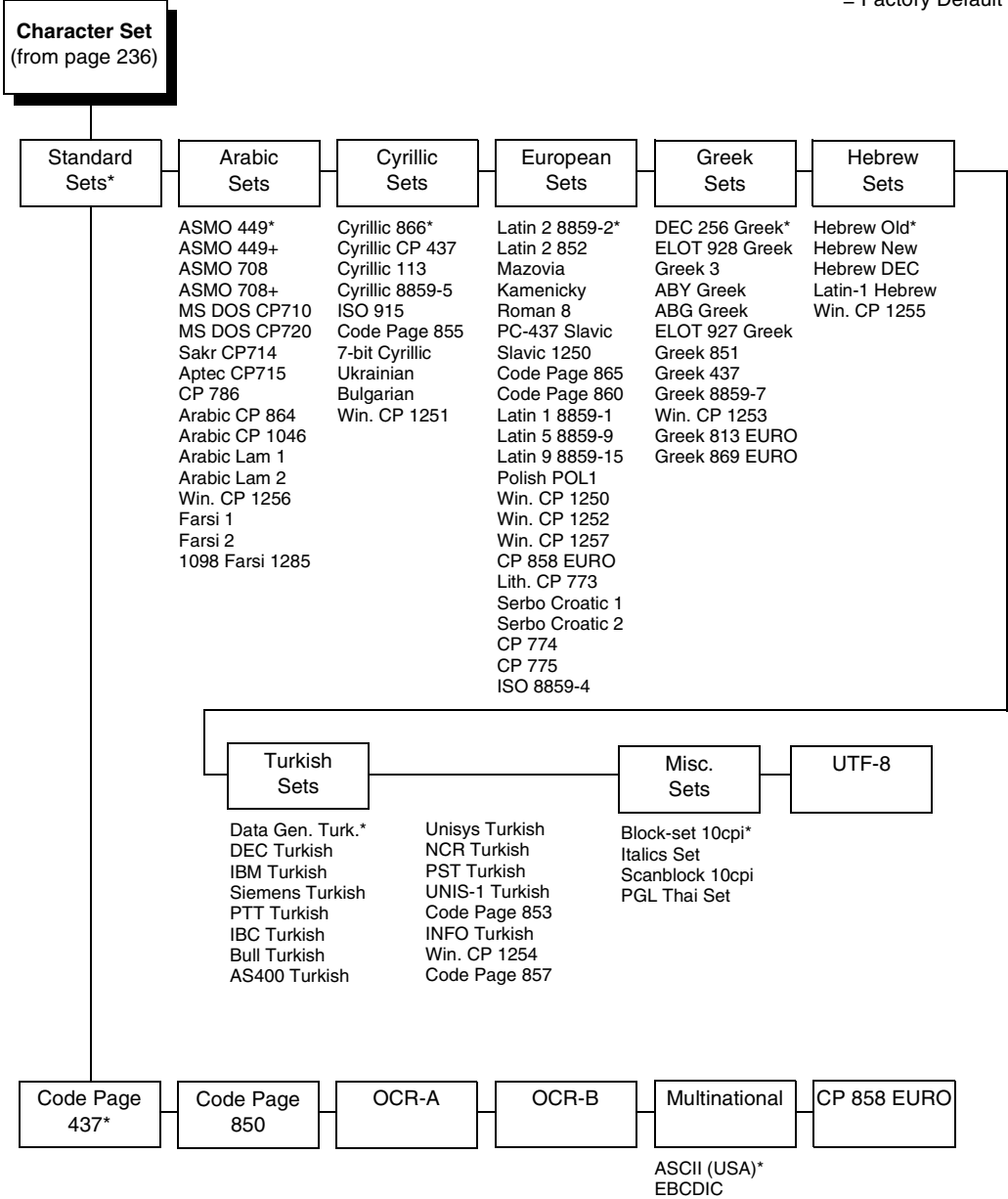

Chapter 4 LinePrinter Plus Emulation (with PCL-II)

Proprinter XL Character Set Menu (with PCL-II)

Character Set
(from page 236)

* = Factory Default

Code Page 437*
Code Page 850
OCR-A
OCR-B
Latin 2 8859-2
Latin 2 852
Bulgarian
Latin 9 8859-15
Polish POL1
Multinational
DEC 256 Greek
ELOT 928 Greek
Greek 3
ABY Greek
ABG Greek
ELOT 927 Greek
Greek 437
Greek 8859-7
PC851 LtGk [12G]
Greek-7 [12N]
Greek-8 [8G]
Hebrew Old
Hebrew New
Hebrew DEC

Proprinter XL Character Set Menu (with LG)

Character Set
(from page 236)

* = Factory Default

Code Page 437*
Code Page 850
OCR-A
OCR-B
Code Page 210
Code Page 220
Code Page 852
Code Page 855
Code Page 857
Code Page 862
Code Page 866
Lithuanian 1
Lithuanian 2
Hebrew New
Hebrew Dec
Hebrew Old
Latin 9 8859-15
CP 858 Euro

Epson FX Emulation

* = Factory Default

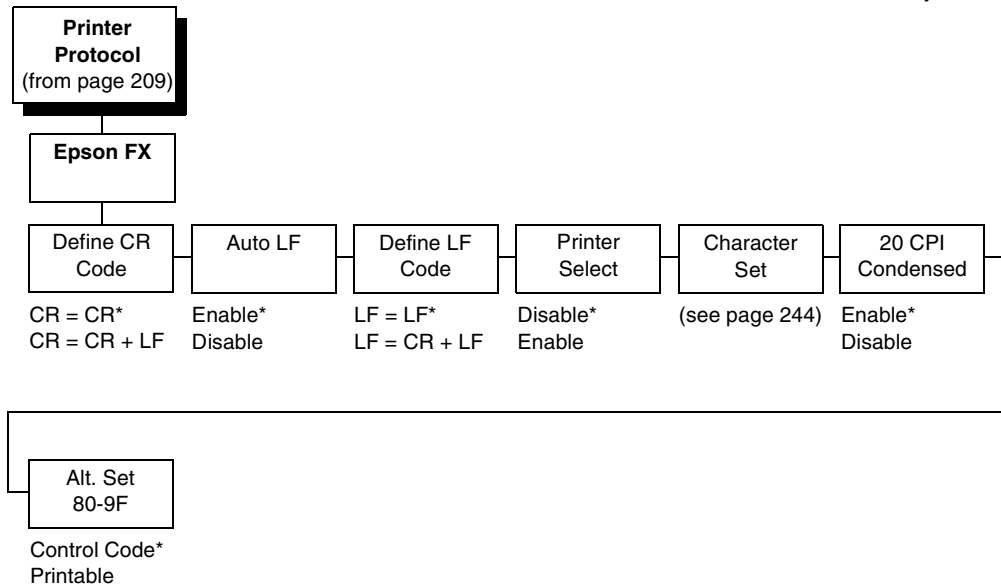

Define CR Code

The Define CR Code option controls the action of the printer when it receives a Carriage Return code (hex 0D) from the host computer. If this feature is enabled, each time the printer receives a carriage return, it inserts an additional Line Feed code (hex 0A) into the data stream. Do not use this feature if the host computer sends line feeds to the printer.

- **CR = CR** (default). Does not insert an extra line feed after each carriage return.
- **CR = CR + LF**. Inserts an extra line feed after each carriage return.

Auto LF

This option defines the printer actions when print data is received past the forms width setting.

- **Enable** (default). Performs an automatic carriage return and line feed when data is received past the forms width.
- **Disable**. Discards any data past the forms width.

Define LF Code

The Define LF Code option controls the action of the printer when it receives a Line Feed code (hex 0A) from the host computer. If this feature is enabled, each time the printer receives a Line Feed, it inserts an additional Carriage Return code (hex 0D) into the data stream. This feature is required if the host computer does not send carriage returns to the printer.

- **LF = LF** (default). Does not add a carriage return with a line feed.
- **LF = CR + LF**. Adds an extra carriage return with each line feed.

Printer Select

- **Disable** (default). Ignores the ASCII DC1 and DC3 control codes.
- **Enable**. Disables the printer when a DC1 control code is received, and enables the printer when a DC3 control code is received.

Character Set

This parameter selects a character set for the Epson emulation, as shown in the “Epson FX Character Set Menu” on page 244. Note that when OCR-A or OCR-B is selected as the print language, the Font Attribute Typeface option under the LinePrinter Plus menu (page 214) is changed to OCR-A or OCR-B, respectively.

To use one of these sets, choose the desired group heading (such as European Sets) and press ENTER. Then choose the desired set within that group (such as Roman 8) and press ENTER. Both the group and the desired set will be starred to indicate your selection. Character sets are shown in detail in the *Character Sets Reference Manual*.

20 CPI Condensed

Compressed print characters are narrower than the normal character set. This is helpful for applications where you need to print the maximum amount of information on a page.

- **Enable** (default). Prints about 60 percent of the width of normal characters when compressed print is chosen by the host computer. For example, a 12 CPI Draft font will compress to 20 CPI.
- **Disable**. Does not compress print widths, even if condensed print is chosen by the host.

Alt. Set 80-9F

- **Control Code** (default). Interprets data in the range of hex 80 through hex 9F as a control code.
- **Printable**. Prints data in the range of hex 80 through hex 9F.

Epson FX Emulation

* = Factory Default

Character Set
(from page 244)

Standard
Sets*

Epson Set*
 ASCII (USA)*
 French
 German
 English
 Danish I
 Swedish
 Italian
 Spanish I
 Japanese
 Norwegian
 Danish II
 Spanish II
 Latin Am I
 French Canadian
 Latin Am II
OCR-A
OCR-B
Multinational
 ASCII (USA)*
 EBCDIC
Code Page 850
CP 858 EURO
IBM PC

Epson FX Character Set Menu (with PCL-II)

* = Factory Default

Character Set
(from page 241)

Epson Set*
ASCII (USA)*
French
German
English
Danish I
Swedish
Italian
Spanish I
Japanese
Norwegian
Danish II
Spanish II
Latin Am I
French Canadian
Latin Am II
OCR-A
OCR-B
Latin 8859-2
Latin 2 852
Cyrillic 866
Bulgarian
Latin 9 8859-15
Polish POL1
Multinational
ASCII (USA)*
EBCDIC
DEC 256 Greek
ELOT 928 Greek
Greek 437
Greek 8859-7
PC851 LtGk [12G]
Greek-7 [12N]
Greek-8 [8G]
Hebrew Old
Hebrew New
Hebrew DEC
IBM PC

Epson FX Character Set Menu (with LG)

Character Set
(from page 241)

* = Factory Default

Epson Set*
ASCII (USA)*
French
German
English
Danish I
Swedish
Italian
Spanish I
Japanese
Norwegian
Danish II
Spanish II
Latin Am I
French Canadian
Latin Am II
OCR-A
OCR-B
Code Page 250
Code Page 220
Code Page 852
Code Page 855
Code Page 857
Code Page 862
Code Page 866
Lithuanian 1
Lithuanian 2
Hebrew Old
Hebrew New
Hebrew Dec
Latin 9 8859-15
CP 858 Euro
IBM PC

Chapter 4 ANSI Emulation

ANSI Emulation

* = Factory Default

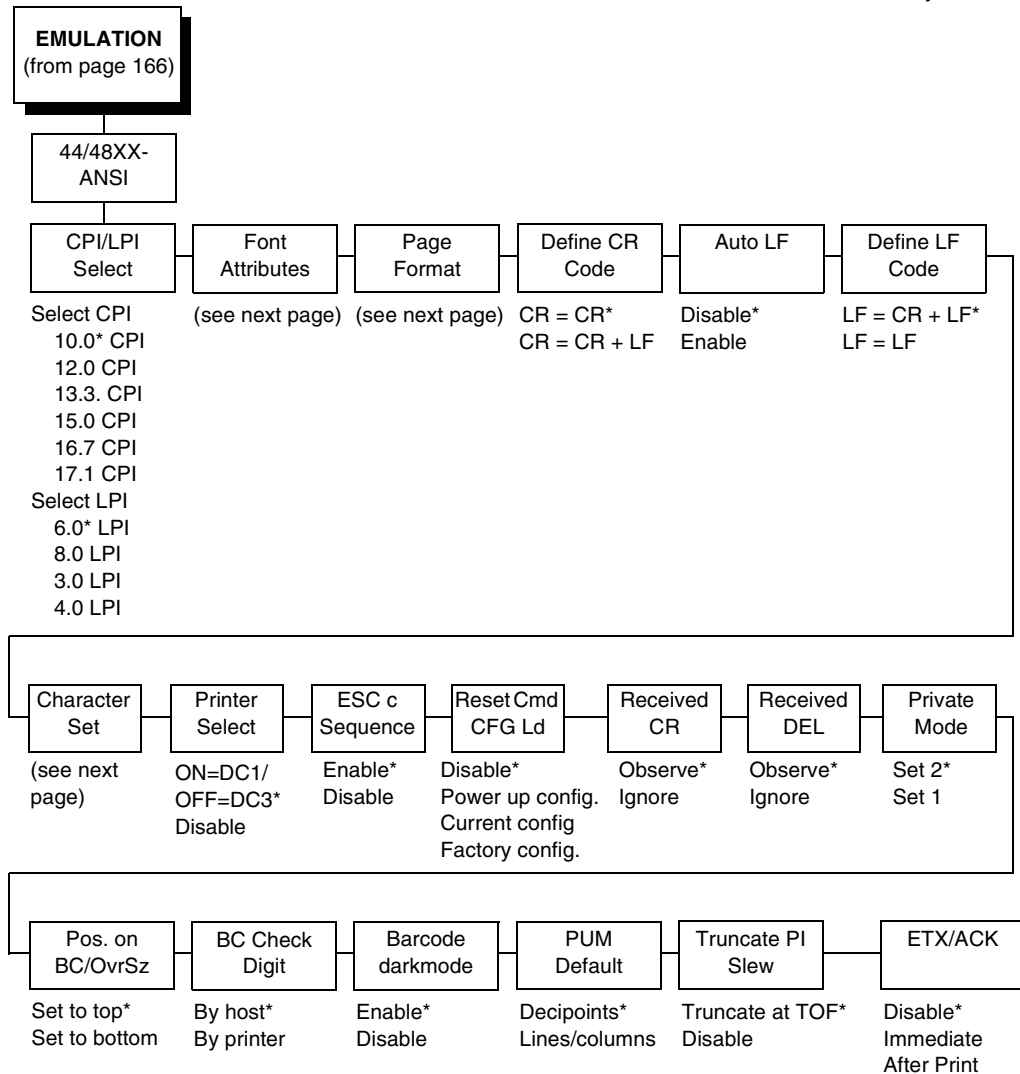

ANSI Emulation

* = Factory Default

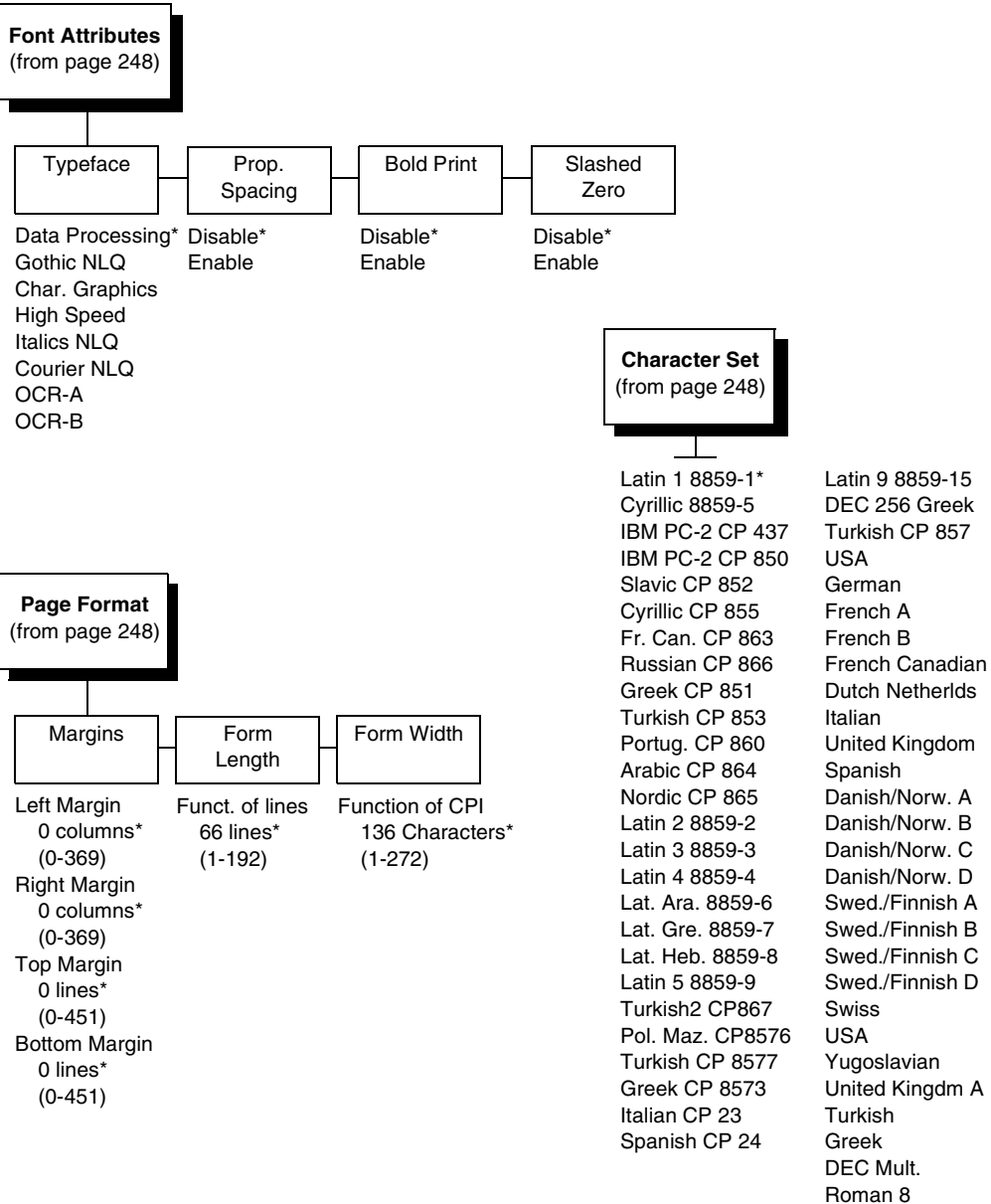

CPI/LPI Select

Defines the default values for the horizontal and vertical character spacing. The number of characters per inch can range from 10.0 through 17.1. The number of lines per inch can range from 3.0 through 8.0.

Font Attributes

Typeface

Choose a typeface from the available options.

Prop. Spacing (Proportional Spacing)

Each printed character is contained inside a character cell. The width of the character cell includes the character and the space around the character.

- **Disable.** Each character cell is printed with the same width. Each column in the printed text will line up.

```
This example is printed with
proportional spacing disabled.
```

- **Enable.** The width of each character cell varies with the width of the character. For example, [i] takes less space to print than [m]. Using proportional fonts generally increases the readability of printed documents, giving text a typeset appearance.

```
This example is printed with
proportional spacing enabled.
```

Bold Print

- **Disable.** Text is printed normally.
- **Enable.** Text is printed with a heavy line thickness.

Slashed Zero

This parameter allows you to print the numeral “0” with or without the slash. This option applies to all character sets except OCR-A and OCR-B.

- **Disable.** Zero is printed without a slash.
- **Enable.** Zero is printed with a slash.

Page Format

Margins

- **Left Margin.** Defines where the first print column is located. The left margin is specified as the number of characters from the left edge of the form.
- **Right Margin.** Defines where the last print column is located. The right margin is specified as the number of characters from the right edge of the form.
- **Top Margin.** Defines the location of the first print line on the page. The top margin is specified as the number of lines from the top of the form's position.
- **Bottom Margin.** Defines the location of the last print line on the page. The bottom margin is specified as the number of lines from the bottom of the form's position.

Form Length

Specifies the form length in lines. The maximum form length in lines depends on the current LPI setting; it is equal to the maximum form length in inches multiplied by the current LPI setting. For example, at 6 LPI the maximum form length is 6 LPI x 24 inches = 144 lines.

Only valid form length values will be accepted. If you select a length that is larger than the maximum length for the current LPI, the maximum length will be used. If you need a longer page length, you must first change the LPI.

IMPORTANT If the form length is set in lines and you change the LPI, the effective page length changes to the form length in characters divided by the new LPI.

NOTE: Receipt of a data stream control code which changes the form length overrides the form length previously specified via the operator panel.

Form Width

Allows you to input the form width in characters from 1 through 272. The maximum form width in characters depends on the current CPI setting; it is equal to the maximum form width in inches multiplied by the current CPI setting.

Only valid form width values will be accepted. If a width is selected that is larger than the maximum width for the current CPI, then the maximum width will be used. If a larger width value is desired, then the CPI value must be changed first.

Table 7 lists the maximum number of characters that can be printed for a given Characters Per Inch (CPI) setting.

IMPORTANT If the form width is set in characters and the CPI is changed, the effective page width is changed to be equal to the form width in characters divided by the new CPI.

Table 7. Form Width

CPI Setting	Maximum Form Width (in characters)
10.0	136
12.0	163
13.3	181
15.0	204
16.7	227
17.1	272

Define CR Code

The Define CR Code option controls the action of the printer when it receives a Carriage Return code (hex 0D) from the host computer. If this feature is enabled, each time the printer receives a carriage return, it inserts an additional Line Feed code (hex 0A) into the data stream. Do not use this feature if the host computer sends line feeds to the printer.

- **CR = CR** (default). No extra line feeds are inserted.
- **CR = CR + LF**. Inserts an extra line feed after each carriage return.

Auto LF

Defines the printer actions when print data is received past the form width setting.

- **Disable** (default). Discards any data past the form width.
- **Enable**. Performs an automatic carriage return and line feed when data is received past the form width.

Define LF Code

Controls the action of the printer when it receives a Line Feed code (hex 0A) from the host computer. If this feature is enabled, each time the printer receives a line feed, it inserts an additional carriage return code (hex 0D) into the data stream. This feature can be used in most installations, but it is required if the host computer does not send carriage returns to the printer.

- **LF = CR + LF** (default). Adds an extra carriage return with each line feed.
- **LF = LF**. Does not add a carriage return with a line feed.

Character Set

This parameter selects a character set for the ANSI emulation. Note that when 0876 OCR-A or 0877 OCR-B is selected as the print language, the Font Attributes Typeface parameter is changed to OCR-A or OCR-B, respectively. Character sets are shown in detail in the *Character Sets Reference Manual*.

Printer Select

- **ON = DC1/OFF = DC3** (default). Disables the printer when a DC1 control code is received, and enables the printer when a DC3 control code is received.
- **Disable**. Ignores the DC1 and DC3 control codes.

ESC c Sequence

- **Enable** (default). An ESC c code received from the host resets the printer parameters to the factory defaults.
- **Disable**. An ESC c code received from the host is ignored.

Reset Cmd CFG Ld

When the printer receives a host data stream reset command (ESC @ or ESC[K) in addition to resetting printer variables, the selected configuration will be loaded.

- **Disable** (default). The active emulation parameters are loaded when the reset command is executed.
- **Power-Up Config**. The power-up configuration is loaded when the reset command is executed.
- **Current Config**. The currently selected configuration is loaded when the reset command is executed.
- **Factory Config**. The factory installed configuration is loaded when the reset command is executed.

Received CR

- **Observe** (default). A CR code received from the host is handled as a carriage return.
- **Ignore**. A CR code received from the host is ignored.

Received DEL

- **Observe** (default). A DEL code received from the host is handled as a Delete command.
- **Ignore**. A DEL code received from the host is ignored.

Private Mode

Determines the default type of character set (Set 1 or Set 2). This can also be set by ESC sequences ESC [>5h and ESC [>5l. Refer to these descriptions in the *ANSI Programmer's Reference Manual* for further details.

Pos. on BC/OvrSz

- **Set to top** (default). The paper is fed back to the top of barcodes or oversized characters after they are printed. This allows printing on the same line.
- **Set to bottom**. The printer will continue printing without backing up.

BC Check Digit

- **By host** (default). The host calculates the barcode check digit and sends it along with the barcode. The check digit is not verified by the printer but printed as it was received.
- **By printer**. The barcode is sent without the check digit, and the printer calculates and adds it in.

Barcode Darkmode

- **Enable** (default). The barcodes are printed at a higher resolution.
- **Disable**. The barcodes are printed at lower resolution but at a higher speed.

PUM Default

This is the Unit of Measure (UOM) as it is used within the ANSI emulation. Coordinates received in ESC sequences can be sent in two UOMs:

- **Decipoints** (default). A unit of 1/720 inch
- **Lines or columns**. Uses the current LPI and CPI values.

The UOM used is determined by this configuration setting.

Truncate PI Slew

- **Truncate at TOF** (default). The slew is terminated when the next Top-of-Form is reached. (This function applies to the ANSI EVFU only.)
- **Disable**. PI slews will be completed independent of their length.

ETX/ACK

End of Text/Acknowledge. The host controls the flow of communication to the printer by sending a block of data and ending the block with an End of Text (ETX) signal. When the printer receives the ETX signal, it acknowledges the ETX, thereby acknowledging it has received the entire block of data.

- **Disable** (default)
- **Immediate**
- **Afterprint**

IPDS Emulation

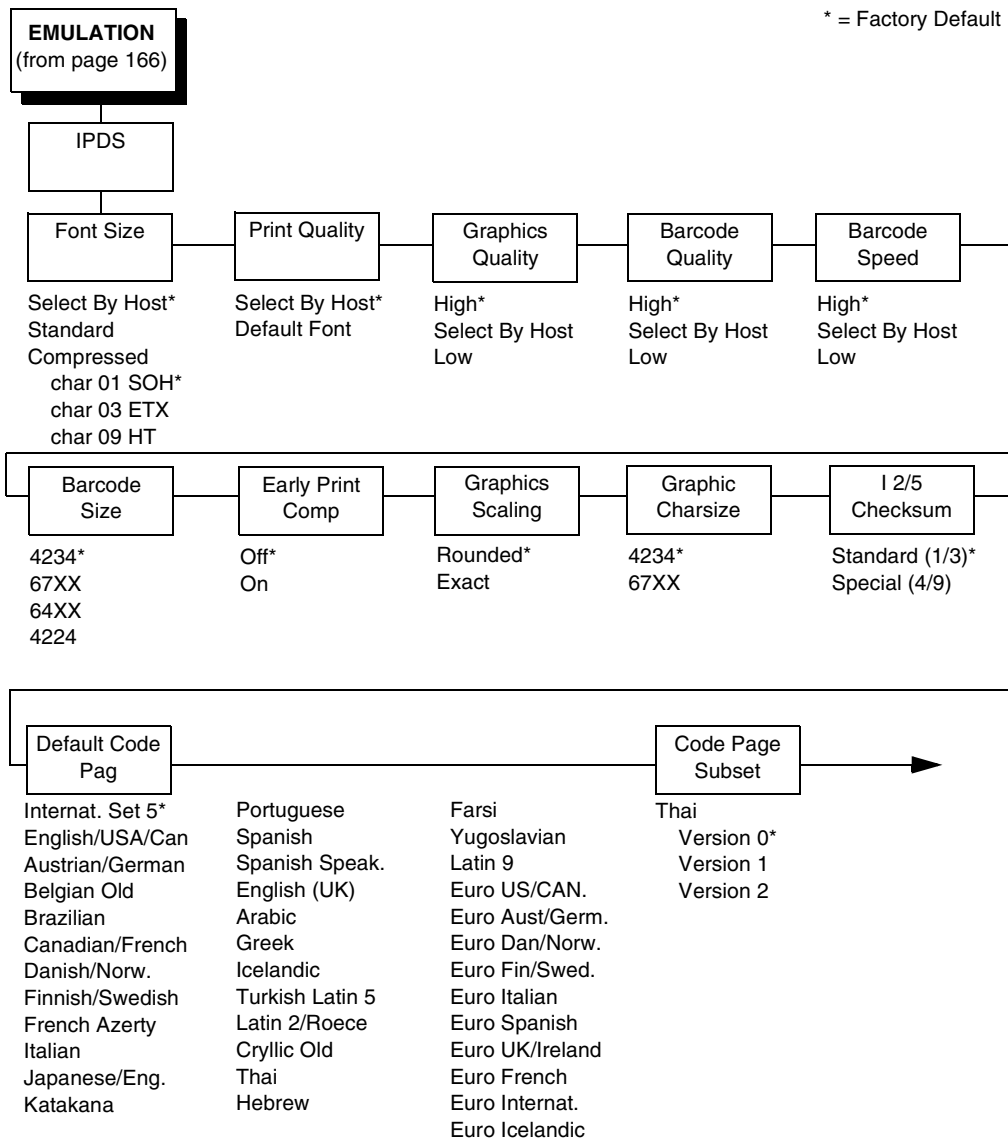

Chapter 4 IPDS Emulation

* = Factory Default

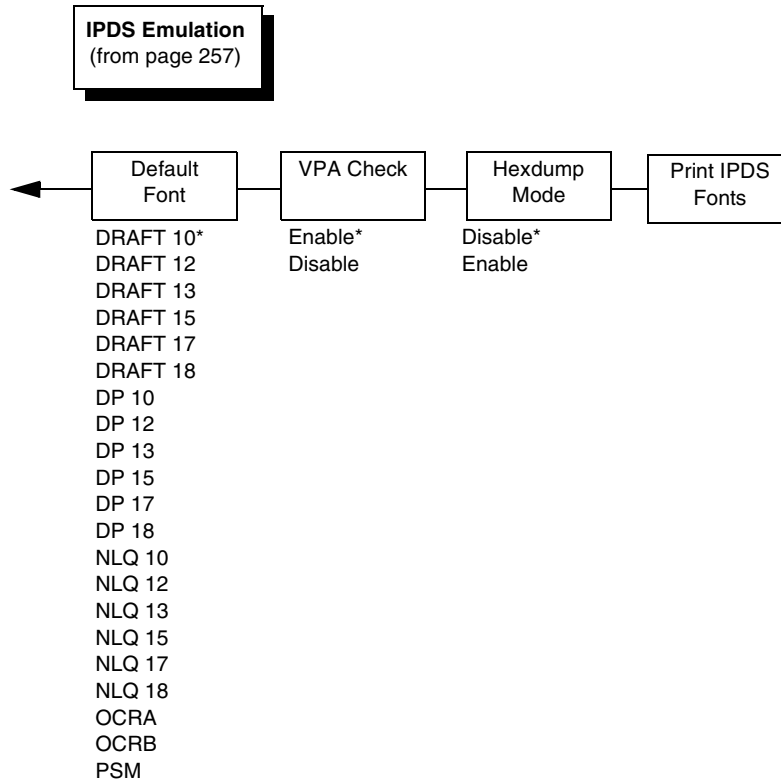

Your IPDS printer emulates the IBM 4234 twinax models 008 and 012.

IPDS Twinax printers can only print IPDS data streams and nothing else. Even a simple job, such as a screen print, is IPDS data in a twinax attachment. Because the printer definition on a twinax host is either set automatically (by auto configuration) or manually, the printer type is already known.

NOTE: A general discussion about starting and stopping IPDS can be found in the IBM 4234 Product and Programming Reference Manual (GC31-3879). Sending a non-IPDS data stream to an IPDS printer and vice versa will result in a hung spool file or writer.

Font Size

This parameter chooses the font size which will be used by IPDS.

- **Select By Host** (default). The font ID is only affected by host commands.
- **Standard**. The font ID is converted to a decompressed font ID.
- **Compressed**. The font ID is converted to a compressed font ID.

Print Quality

This parameter chooses the print quality.

- **Select By Host** (the default). The application decides the print quality.
- **Default Font**. The default font the printer uses.

Graphics Quality

This parameter chooses the print quality of graphics.

- **High** (default). Graphics are printed at 144 dot rows per inch.
- **Select By Host**. The application decides the quality of the graphics.
- **Low**. Graphics are printed at 72 dot rows per inch.

Barcode Quality

This parameter chooses the horizontal print quality of barcode labels.

- **High** (default). Label is printed at 144 dots per inch.
- **Select By Host**. The application decides the quality of the labels.
- **Low**. Label is printed at 72 dots per inch.

Barcode Speed

This parameter chooses the vertical print quality of barcode labels.

- **High** (default). Barcodes are printed with less vertical dots, increasing printing speed, but decreasing print quality.
- **Select By Host**. The application decides the quality of the labels.
- **Low**. Barcodes are printed with more vertical dots, decreasing printing speed, but increasing print quality.

Barcode Size

This parameter will emulate the barcode sizes of the selected printer model.

- **4234** (default). IBM 4234
- **67XX**. Decision Data 67XX
- **64XX**. IBM 6400 series
- **4224**. IBM 4224

Early Print Comp (Complete)

This parameter chooses when to send a Print Comp to the controller.

- **Off** (default). Print Comp is sent if page is printed completely.
- **On**. Print Comp is sent immediately. The next page will be created. This improves the print performance when starting the next page.

NOTE: When Early Print Comp is enabled and an error occurs, you may lose data.

Graphics Scaling

This parameter chooses the scaling factor for graphics when the Mappin. Control option of the IPDS Write Graphics Control command is SCALE TO FIT:

- **Rounded** (default). Calculations are rounded up in the desired output resolution.
- **Exact**. Graphics will be scaled as accurately as possible.

Graphic CharSize

This parameter will emulate the graphic character size of the selected printer model.

- **4234** (default). IBM 4234
- **67XX**. Decision Data 67XX

I 2/5 Checksum

This parameter defines the printer checksum calculation method for Interleaved 2 of 5 barcodes.

- **Standard (1/3)** (default). The odd numbers will be multiplied by 3 and the even numbers by 1 for calculation of the checksum.
- **Special (4/9)**. The odd numbers will be multiplied by 4 and the even numbers by 9 for calculation of the checksum.

NOTE: “Odd” refers to the 1st, 3rd, 5th... character in the barcode, while “even” refers to the 2nd, 4th, 6th... character in the barcode.

Default Code Pag

Choose which code page to use with the IPDS emulation. This option is independent of the Character Set selection in the CTHI emulation.

Code Page Subset

When the Thai code page is selected as the default, either from the front panel or by a host command, you may choose from three different versions.

Default Font

Choose a font quality and size from the available selections. All fonts in the Default Font menu are available in standard and compressed vertical resolution (see page 257).

VPA Check

- **Enable** (default). The printer checks for dots that fall outside the intersection of the logical and physical pages. If dots fall outside the area, the printer reports an error to the host if the IPDS Exception Handling Control command setting requires error reporting.
- **Disable**. The printer does not report dots outside the valid printable area.

Hexdump Mode

A hex code printout (or hex dump) translates all incoming data to hexadecimal equivalents. A hex dump lists each ASCII data character received from the host computer, together with its corresponding two-digit hexadecimal code. Hex dumps can be used to troubleshoot some types of printer data reception problems.

Print IPDS Fonts

This feature allows you to print a list of all resident fonts currently available in the active IPDS emulation

PCL - II Emulation

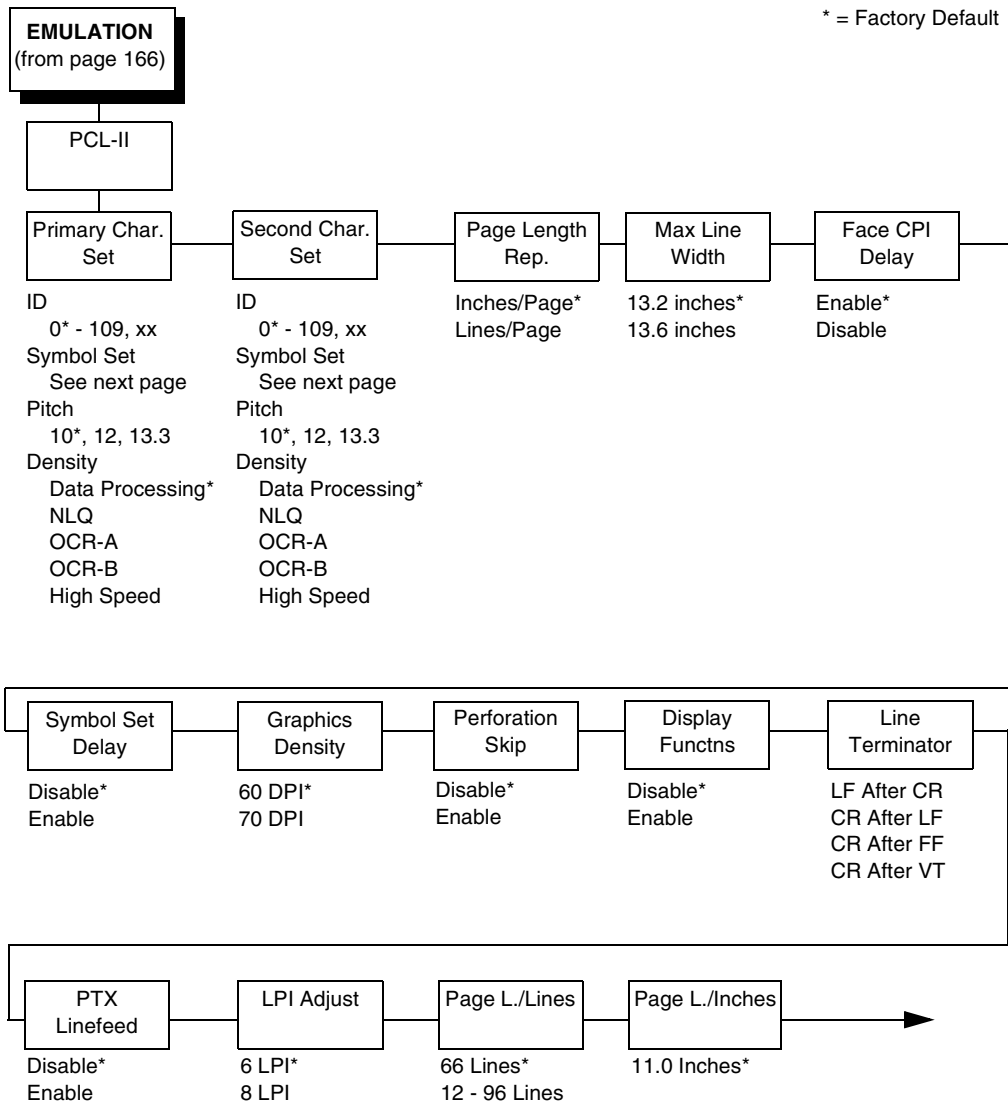

Chapter 4 PCL - II Emulation

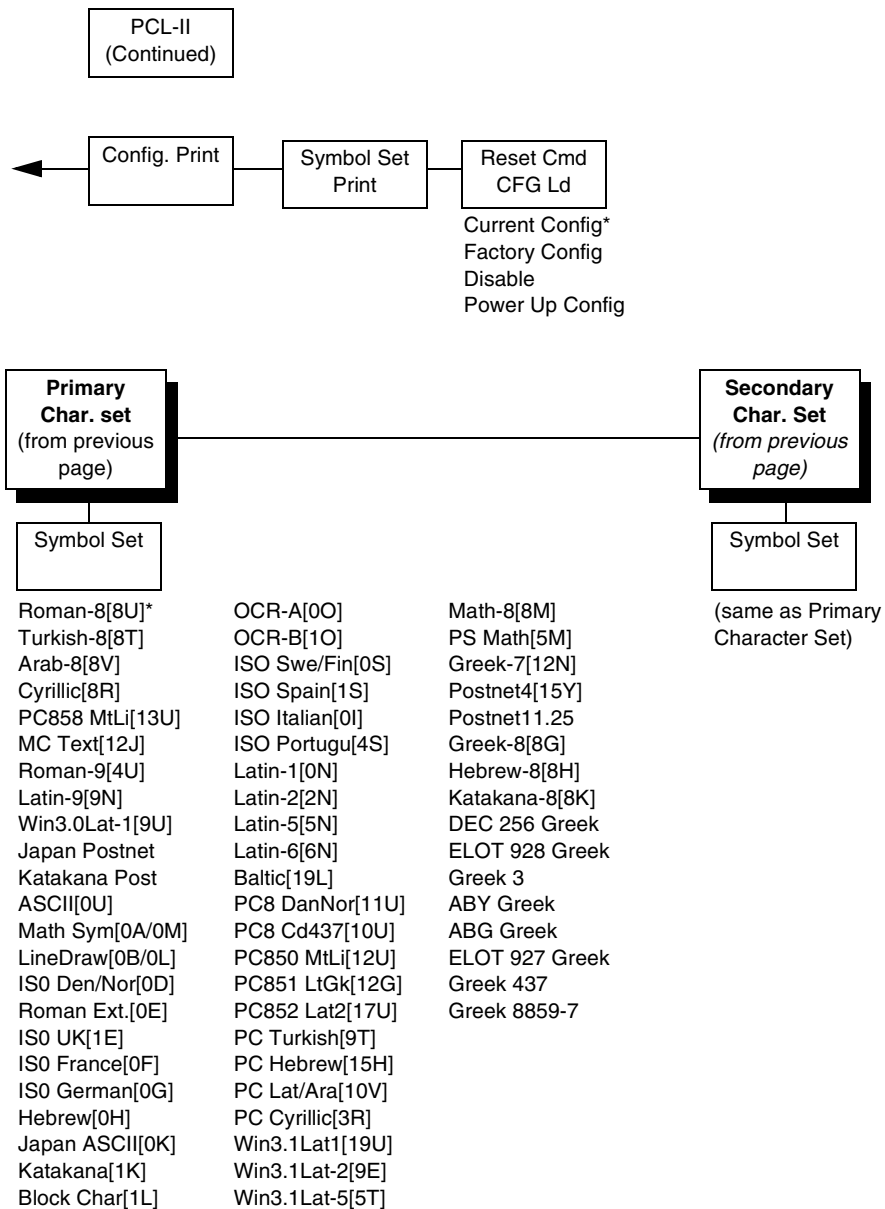

Primary Char. Set

You can select one of 92 pre-defined character sets by ID (although character sets range from 0 - 109, not all sets are available on the LJ500 printer), or you can select pitch, symbol set, and typeface individually. If the combination you choose matches one of the 92 predefined sets, the ID submenu will reflect that selection. If not, the ID menu will display xx to indicate that the current character set does not match a pre-defined set. Set 0 is the default, and its attributes are 10 cpi, Data Processing typeface, and Roman 8 symbol set.

Second Char. Set

Your printer can store an additional character set. To toggle between them, send the Shift In (Decimal 15, to select the Primary character set) or Shift Out (Decimal 14, to select the Secondary character set).

Page Length Rep.

- **Inches/Page** (default). All page length calculations are based on the inches displayed on the panel.
- **Lines/Page**. All changes in LPI or density will be changed accordingly. The length of the page is the number of lines per inch, or lpi.

For example, if the form in use is 82 lines at 6 lpi, the page is physically 13.67 inches. Since 13.67 inches is not selectable from the Length in Inches menu, change the representation to lines, then set the number of lines to 82. The inches menu will display 13.6 inches although the printer internally keeps the exact form length of 13.67 inches.

Max Line Width

Set the maximum line width at 13.2 inches (the default) or 13.6 inches.

Face CPI Delay

Allows the combination of different font densities on the same line.

- **Enable** (default). Different font densities can be used on the same line.
- **Disable**. Only the same font densities are allowed on the same line.

Graphics Density

Graphics can be printed in 60 DPI (the default) or 70 DPI.

Perforation Skip

- **Disable** (default). Allows printing on page perforation.
- **Enable**. You may set up a skip-over margin. For example, a skip-over margin of one inch creates a one inch margin at the bottom of the page.

Display Functions

- **Disable** (default). The default. Control characters are not printed.
- **Enable**. Control characters are printed before they get executed. This is a useful debugging tool.

Line Terminator

You can define the action of the line. Four options are available: LF after CR, CR after LF, CR after FF, and CR after VT. Each of these options may be enabled or disabled independent of one another.

PTX Linefeed

- **Disable** (disable). The default. Linefeed is to be performed as calculated from the bottom of the graphics or barcode, thereby disrupting the vertical text alignment.
- **Enable**. The Linefeed moves to the next line as calculated from the Top of Form position, thereby retaining vertical text alignment. When printing graphics or bar codes, you may want to set the PTX Linefeed parameter to Enable to maintain text alignment.

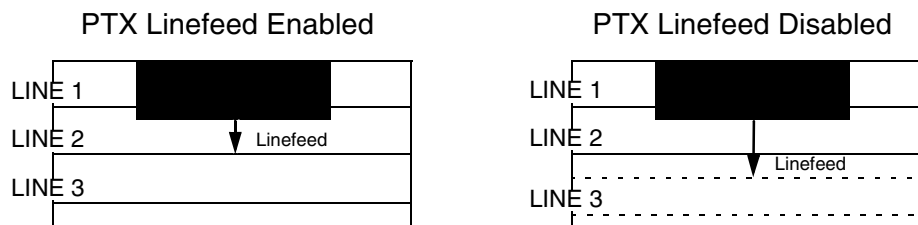

LPI Adjust

This parameter lets you specify the lines per inch (lpi) values: 6 LPI (the default) or 8 LPI.

Page L./Lines

This parameter lets you set physical page length in lines from 12 to 96 at 6 lpi, or 16 to 128 at 8 cpi. The default is 66 lines at 6 lpi.

NOTE: If 6 lpi is selected, you will be able to scroll the menu to 128 (an invalid length). However, when you press ENTER to select this value, the menu will return with the maximum lines for 6 lpi (i.e., 96 lines). Similarly, selecting too few lines for 8 lpi will cause the menu to return with 16 lines.

Page L./Inches

This parameter allows you to set physical page length from 2 to 16 inches, in increments of half an inch. The default is 11 inches.

Config Print

This option prints the emulation's parameters and the currently selected values.

Symbol Set Print

This option prints a list of all the available sets. The character set number prints to the left of the character set sample.

Reset Cmd CFG Ld

When the printer receives a host data stream reset command in addition to resetting printer variables, the selected configuration will be loaded.

- **Power-Up Config** (default). The power-up configuration is loaded when the reset command is received.
- **Current Config**. If you have preset and presaved multiple configurations, then the currently selected presaved configuration is loaded when the reset command is received.
- **Disable**. The printer ignores the reset command when it is received and continues to use the currently loaded configuration.
- **Factory Config**. The factory installed configuration is loaded when the reset command is received.

LG Emulation

EMULATION
(from page 166)

* = Factory Default

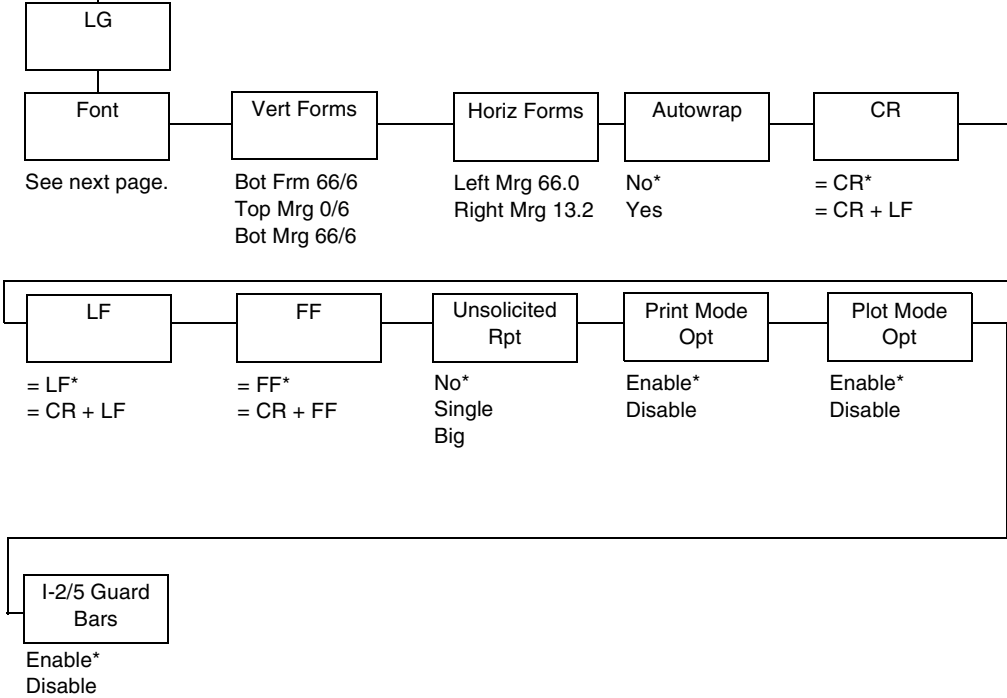

Chapter 4 LG Emulation

Font
(from previous
page)

Style

DP 10 6*
DP 10 8
DP 12 6
DP 12 8
DP 15 6
DP 15 8
DP 15 10
HS 10 6
Corespon 5 6
Corespon 5 8
Corespon 6 6
Corespon 6 8
Corespon 10 6
Corespon 10 8
Corespon 12 6
Corespon 12 8
Corespon 15 6
Corespon 15 8
Corespon 15 10
OCR A
OCR B
Compress 6 6
Compress 6 8
Compress 8 6
Compress 8 8
Compress 13 6
Compress 13 8
Compress 13 10
Compress 16 6
Compress 16 8
Compress 16 10
DP 56
DP 58
DP 66
DP 68

Character Set

GL Char Set
U.S. ASCII*
DEC Finnish
French
DEC Fr. Can.
German
Italian
JIS Roman
DEC Nor./Dan.
Spanish
DEC Swedish
DEC Great Brit.
ISO Nor./Dan.
DEC Dutch
DEC Swiss
DEC Portuguese
VT100 Graphics
DEC Suppl.
DEC Technical
ISO Katakana
7-Bit Hebrew
7-Bit Turkish
Greek Suppl.
Hebrew Suppl.
Turkish Suppl.
GR Char Set
DEC Suppl.*
DEC Technical
VT100 Graphics
ISO Katakana
ISO Latin 1
ISO Latin 2
ISO Latin 9
ISO Cyrillic
ISO Greek
ISO Hebrew
Hebrew Suppl.
Turkish

Font

Select a default font style and character set for the LG emulation, as follows:

- **Style.** This option allows you to specify a print quality that includes a characters per inch (cpi) and lines per inch (lpi) setting, in the format Type cpi lpi. The default setting is DP 10 6 (Data Processing, 10 cpi, 6 lpi). The print quality types you may choose from are as follows:

DP = Data Processing (standard quality)

CORRESPON = Correspondence (near letter quality)

COMPRESS = Compressed (vertically compressed for printing long graphs and charts)

OCR A & OCR B = Optical Character Recognition, sets A and B

HS = High Speed (Draft quality for high speed printing)

- **Character Set.** This option allows you to select a character set. The character set you select can be any of the Digital Multinational sets, which include the U.S. ASCII set and several foreign language and special character sets.

Vert Forms

- **Bot Frm 66/6** (default). This option sets the bottom margin for the forms. You must specify the bottom margin in lines (at 6 lines per inch), ranging from 0 to 198 lines (33 inches). The default setting is 66. Press the right arrow to increase the value, left arrow to decrease the value, and ENTER to change units. Selecting a value for this option resets the top margin to 0, so the top margin must be redefined after this option is selected.

- **Top Mrg 6/0.** This option sets the top margin for the forms. You must specify the top margin in lines (at 6 lines per inch), ranging from 0 to 198 lines (33 inches). The default setting is 0. Press the right arrow to increase the value, left arrow to decrease the value, and ENTER to change units. The margins will automatically adjust so that the top and bottom margins do not cross each other.
- **Bot Mrg 66/6.** This option sets the bottom margin for the forms. You must specify the bottom margin in lines (at 6 lines per inch), ranging from 0 to 198 lines (33 inches). The default setting is 66. Press the right arrow to increase the value, left arrow to decrease the value, and ENTER to change units. Selecting a value for this option resets the top margin to 0, so the top margin must be redefined after this option is selected.

Horiz Forms

- **Left Mgr 0.00** (default). This sets the left margin for the forms. You must specify the left margin in 1/10 inch increments, from 0 to 13.1 inches. The default value is 0. Press the right arrow to increase the value, left arrow to decrease the value, and ENTER to change units. The margins will automatically adjust so that the left and right margins do not cross each other.
- **Right Mrg 13.2.** This sets the right margin for the forms. You must specify the right margin in 1/10 inch increments, from 0.1 to 13.2 inches. The default value is 13.2. Press the right arrow to increase the value, left arrow to decrease the value, and ENTER to change units. The margins will automatically adjust so that the left and right margins do not cross each other.

Autowrap

This parameter determines if text will wrap to the next line when the line of text exceeds the right margin.

- **No** (default). Any print data received past the forms width setting is discarded.
- **Yes.** An automatic carriage return and line feed is performed when data is received past the forms width setting.

CR

This option controls the action of the printer when it receives a Carriage Return code (hex 0D) from the host computer. If this feature is enabled, each time the printer receives a Carriage Return, it inserts an additional Line Feed code (hex 0A) into the data stream. Do not use this feature if the host computer sends line feeds to the printer.

- = **CR** (default). Does not insert an extra line feed after each carriage return.
- = **CR + LF**. If this feature is enabled, each time the printer receives a Carriage Return, it inserts an additional Line Feed code (hex 0A) into the data stream. (Do not use this feature if the host computer sends Line Feeds to the printer with each Carriage Return.)

LF

This parameter forces the printer to insert an automatic Carriage Return code into the data stream whenever a Line Feed code occurs. This can be used in most installations, but it is required if the host computer does not send carriage returns to the printer.

- = **LF** (default). Does not perform an automatic carriage return. The next print position will be the current print position of the next line.
- = **CR + LF**. Each time the printer receives a Line Feed, it inserts an additional Carriage Return code (hex 0D) into the data stream. This feature can be used in most installations, but it is required if the host computer does not send Carriage Returns to the printer.

FF

This parameter forces the printer to insert an automatic Carriage Return code into the data stream whenever a Form Feed code occurs. This can be used in most installations, but it is required if the host computer does not send carriage returns to the printer.

- = **FF** (default). Does not perform an automatic carriage return. The next print position will be the current print position of the next form.
- = **CR + FF**. Performs an automatic carriage return. The next print position will be print position 1 of the next form.

Unsolicited Rpt

This option enables or disables Printer Device Status Reports to be sent to the host when a reportable status or error condition has occurred.

- **No** (default). Disables all unsolicited status reports from the printer.
- **Small**. Enables brief unsolicited status reports and sends an extended status report to the host.
- **Big**. Enables extended, unsolicited status reports and sends an extended status report to the host.

Print Mode Opt

When enabled, this option affects the SPI, SHS, and DECShORP commands. The printer will no longer be forced into these commands and print speed improves significantly when in portrait orientation. For SHS and DECShORP, the character size will change with the selected pitch. In addition, SGR attributes such as bold, crossed-out, and italics, will be done in print mode with greater efficiency.

- **Disable** (default). Disables the print mode option. This provides compatibility with older LG printer products.
- **Enable**. Enables the print mode option.

Plot Mode Opt

When enabled, this option will plot with greater efficiency, particularly with respect to the Postnet barcode. Postnet is printed in the same density as the current print mode font so that reverse motion will be inhibited when possible.

- **Disable** (default). Disables the print mode option. This provides compatibility with older LG printer products.
- **Enable**. Enables the print mode option.

I-2/5 Guard Bars

- **Disable** (default). Interleaved 2/5 bar codes are printed normally, with no guard bars.
- **Enable**. Horizontal guard bars are printed above and below each Interleaved 2/5 bar code. This option only applies to Interleaved 2/5 bar codes.

Chapter 4 PRINTER CONTROL

PRINTER CONTROL

PRINTER CONTROL (from page 70)

* Factory Default
¹ Not available in LG or PCL-II

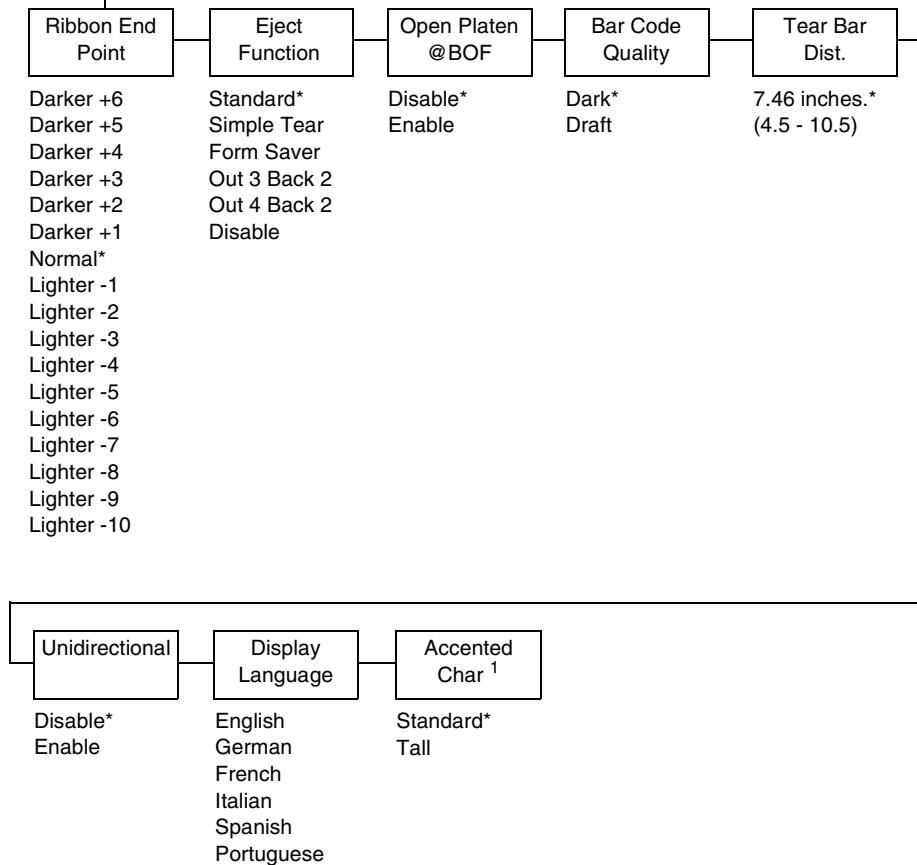

Ribbon End Point

This parameter adjusts the point at which the system will declare the ribbon as being expended. The life count will always be from 100% to 0%, but if a darker setting is selected 0% will be reached more quickly. If a lighter setting is selected, the system will extend the time it takes to reach 0%. The range of values are as follows:

- **Normal** (default)
- **Darker +1 through Darker +6**
- **Lighter -1 through Lighter -10**

NOTE: This value can be adjusted at any time and the display will automatically adjust to show the correct percentage relative to the new end point.

Eject Function

Enables and defines the eject function to be used. When activated, the function is used by holding down the VIEW/EJECT key for more than one second in offline mode.

- **Standard** (default). Slews the paper two 11" pages when VIEW/EJECT is pressed for more than one second. Pressing VIEW/EJECT a second time retracts two pages.
- **Simple Tear.** Allows demand printing for specially designed forms which require a header of at least 2.66 inches in height. This leader prevents the paper from falling out of the tractors when the demanded sheet is removed.

Press the VIEW/EJECT key. The printer slews the bottom of the last printed form to the tear position. Tear the paper, then press the VIEW/EJECT button again. The paper reverses the exact amount of paper it slewed, placing the print position to the next available page. See "Demand Printing" on page 329 for detailed information on Simple Tear.

Chapter 4 PRINTER CONTROL

- **Form Saver.** Allows near demand printing for forms that do not have pre-printed headers or special application designs. At least one blank page is required to load the paper so that it does not slip out of the tractors. For shorter form lengths, two or more blank pages may be necessary. When you press VIEW/EJECT, the bottom of the printed page is slewed to the tear position. When pressed again, the paper moves to the top of the next printable page available. See “Demand Printing” on page 329 for detailed information on Form Saver.
- **Out 3 Back 2.** A page eject command moves to top-of-form three times then positions backward for two pages, giving the effect of a single page eject.
- **Out 4 Back 2.** A page eject command moves to top-of-form four times then positions backward for two pages, giving the effect of a single page eject.
- **Disable.** Prevents the use of the eject function.

Open Platen @ BOF (Bottom of Form)

Some special forms have perforation areas that are too thick to pass through the print station. This parameter, when enabled, opens and closes the platen when the perforations move across the platen. When enabling this parameter, you must set the forms length to match the physical distance between perforations.

Bar Code Quality

Determines the bar code resolution for all emulations, except IPDS. (See “IPDS Emulation” on page 257 to set the bar code quality for IPDS.)

- **Dark** (default). Bar code resolution is set at 120 x 72.
- **Draft**. Bar code resolution is set at 60 x 72.

Tear Bar Dist. (Distance)

Allows fine and course adjustment of the tear bar position. For a pedestal model printer using the top paper exit, the default (7.46 inches) is used. You can specify 4.5 to 10.5 inches in .01 inch increments to accommodate variations in cover and form design.

Unidirectional

The Unidirectional feature affects both print quality and printing speed. By setting this feature, you can configure the printer to print in both directions of the shuttle sweep (bidirectional), or to print in one direction only (unidirectional).

- **Disable** (default). The printer will print all data in both directions of the shuttle sweep (bidirectional printing). This choice produces higher printing speed.
- **Enable**. The printer will print all data in only one direction of the shuttle sweep (unidirectional printing). Although enabling this feature reduces print speed, it enhances the vertical alignment of dots and produces cleaner, sharper barcodes and text.

Display Language

This parameter chooses the language that will appear on the LCD: English, German, French, Italian, Spanish, or Portuguese. The factory default is English.

Accented Char

Selects whether the accented characters are standard or tall. See Figure 23 for an example. Selecting tall will slow print speed and may cause the printer to back up during printing.

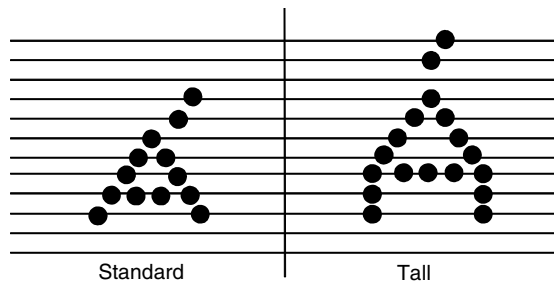
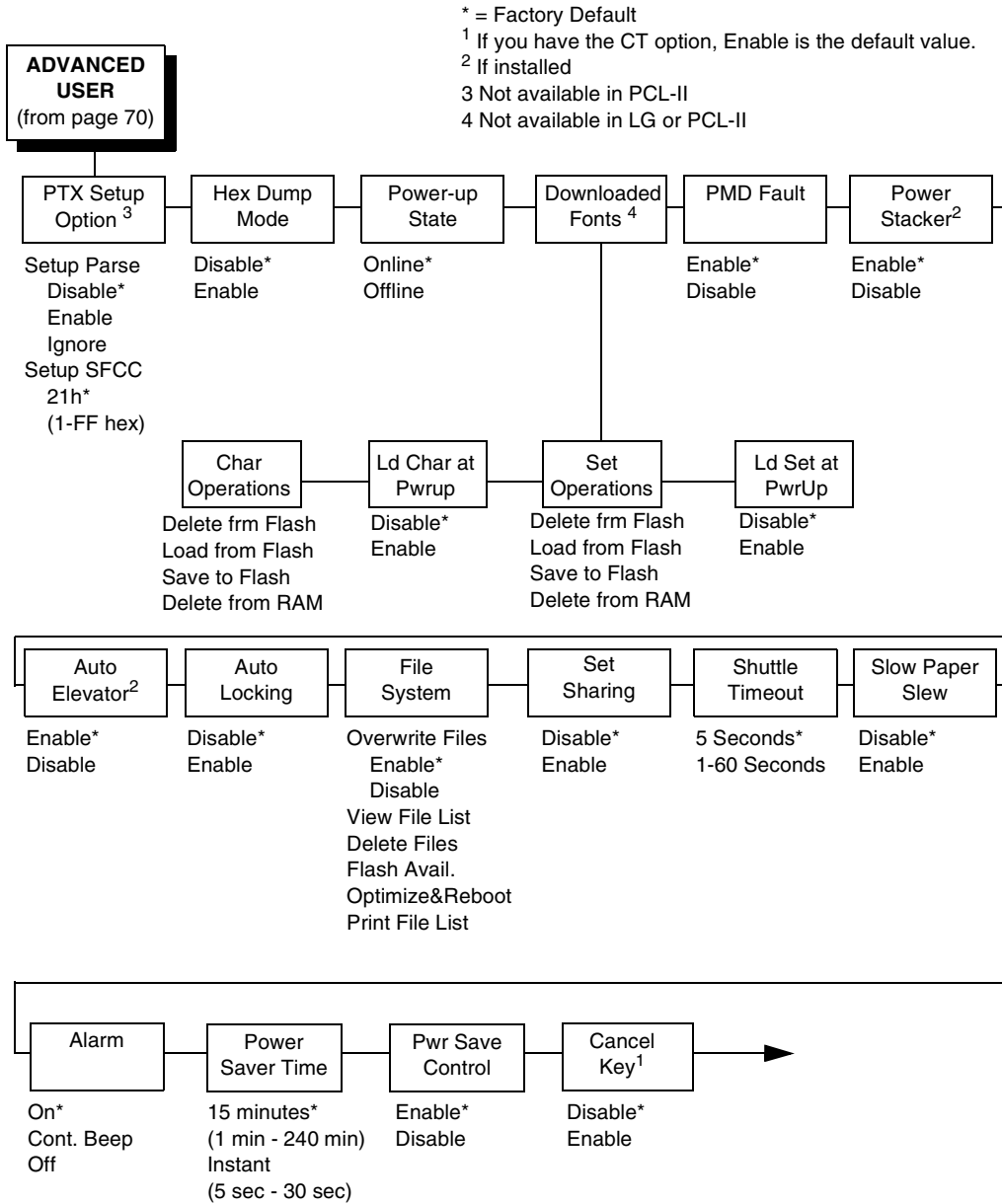
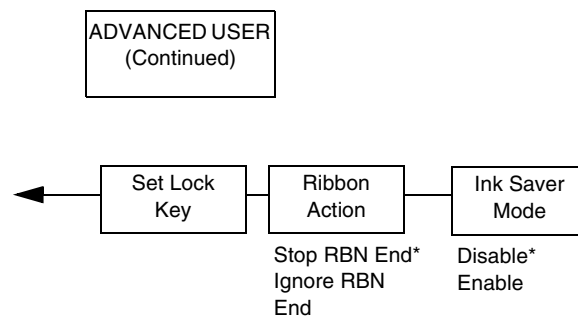

Figure 23. Accented Characters

ADVANCED USER





PTX Setup Option

Selects the Special Function Control Code for the PTX_SETUP command and functions.

- **Setup Parse.** Disables or enables the PTX_SETUP command.
- **Setup SFCC.** Allows you to choose the hex value of the ASCII character you wish to use as the SFCC for the PTX_SETUP command. Valid hex values are 01-FF. The default value is hex 21, which corresponds to the “!” character.

Hex Dump Mode

A hex code printout (or hex dump) translates all incoming data to hexadecimal equivalents. A hex dump lists each ASCII data character received from the host computer, together with its corresponding two-digit hexadecimal code. Hex dumps can be used to troubleshoot some types of printer data reception problems. The options include:

- **Disable** (default)
- **Enable**

Figure 27 on page 315 shows a hex dump sample.

Power-Up State

- **Online** (default). The printer powers up in the online state.
- **Offline**. The printer powers up in the offline state.

NOTE: This option is not available in the PCL-II or LG emulation.

Downloaded Fonts

Allows you to download a substitution table to replace any character in the current character set with a different character in the same font.

- **Char Operations**. Allows you to delete a character from flash, load a character from flash, save a character to flash, and delete a character from RAM.
- **Ld Char at Pwrup**. Allows you to disable or enable loading a character at power up.
- **Set Operations**. Allows you to delete a character set from flash, load a character set from flash, save a character set to flash, and delete a character set from RAM.
- **Ld Set at PwrUp**. Allows you to disable or enable loading a character set at power up.

NOTE: This option is not available in the PCL-II or LG emulation.

PMD (Paper Motion Detection) Fault

- **Enable** (default). In the event of a paper jam, an audible alarm beeps, "CLEAR PAPER JAM" appears on the message display, and the printer stops printing.
- **Disable**. You should disable PMD only if special paper requires it.

CAUTION Once PMD is disabled, paper motion is not monitored. If a paper jam occurs, the printer ignores the condition and continues to print, possibly causing damage to the printer.

Power Stacker

This parameter allows you to enable or disable the power paper stacker (provided this option is installed).

Auto Elevator

This parameter exists only on printers with the power paper stacker installed. The power stacker has a sensor which detects paper movement and raises the stacker as the printed paper stack grows. If the printer has been printing for three minutes continually and the sensor has not detected any growth in the paper stack, the stacker raises itself 1/4 inch automatically.

- **Enable** (default). The automatic elevator on the power stacker operates normally.
- **Disable**. The stacker does not raise automatically every three minutes and is entirely dependent on the sensor. Disable is used with extremely high-quality print jobs that take a long time to print.

Auto Locking

- **Disable** (default). The ENTER key must be locked manually.
- **Enable**. The printer automatically locks the ENTER key five minutes after the last front panel key press.

File System

- **Overwrite Files.** Allows you to prevent files from being overwritten by disabling the overwrite function.
- **View File List.** Displays the list of files in the file system. Pressing the DOWN key displays the file size.
- **Delete Files.** Displays the list of files in the file system. Pressing the ENTER key deletes the file displayed on the front panel.

Flash Avail. The amount of flash available for the user to save or download files into flash.

- **Optimize&Reboot.** Reclaims flash space from deleted flash files. After pressing ENTER, wait for the printer to reboot.

NOTE: When the Optimize&Reboot option is executed, the message, “Optimizing Flash Files” does not display before printer rebooting takes place.

- **Print File List.** Prints a summary of the files stored in flash memory and several statistics on File System usage.

IMPORTANT

Do not turn the printer off until it has completely rebooted and is either back online or offline.

Set Sharing

This option allows character sets to be shared between the active LP+ protocol and the active IGP emulation. If CT is installed and active, choosing a character set in the CT activates that character set in the active IGP and LP+ protocols. (These changes will not be visible on the front panel.) If Set Sharing is not selected, only the LP+ will share the CT's character set.

Switching host interfaces from CT to Centronics when the Set Sharing is enabled will cause the LP+ character set to be activated to the same character set of the active IGP, if possible.

In a non-CT system, changing characters sets in LP+ causes the active IGP to change to the same character set if the selected set exists in IGP. If the active IGP has no access to the selected set, no changes are made. Selecting a new character set in the active IGP causes the LP+ to change to the same character set if the selected character set exists in the active LP+ protocol. Not all sets are shared between emulations in the Standard group of character sets. As a result, selecting a set in the Standard group of LP+ or IGP emulation may or may not cause the other emulation to have the same set.

NOTE: The front panel option, Set Sharing, has no effect on the LP+ and CT/LP+ builds. The option only applies to the builds with IGP.

This option is not available in the PCL-II or LG emulation.

Shuttle Timeout

The amount of time the shuttle continues moving after no data is received. If your host is slow, setting the number to a higher value will prevent the printer from spending time shuttling up and down between data bursts.

Slow Paper Slew

- **Disable** (default). The paper will slew and stack paper at maximum speed.
- **Enable**. Causes the paper to stack at a slower rate. This ensures that certain forms will stack neatly.

Alarm

- **On** (default). An audible alarm sounds (3 beeps) when a fault occurs, such as a paper jam.
- **Cont. Beep**. A continuous audible alarm sounds when a fault occurs, which can be stopped by pressing CLEAR.
- **Off**. No audible alarm will sound.

Power Saver Time

The time interval you specify for this parameter sets the amount of idle time before the printer goes into Power Saver mode. When Instant is chosen, the printer goes into Power Saver mode as soon as it is able to stop the shuttle properly. The time allotted to perform this function depends upon the shuttle timeout value which can be set in the menu.

Pressing any key will remove the power saver message from the control panel. Sending a print job to the printer will turn off power saver mode.

Pwr Save Control

Allows you to enable or disable the Power Save (Energy Star) mode.

- **Enable** (default). Allows you to enable the Power Save (Energy Star) mode.
- **Disable**. Allows you to disable the Power Save (Energy Star) mode.

Cancel Key

- **Disable** (default)
- **Enable**. The CANCEL key may be used to clear all data in the print buffer without printing any of the data.

Set Lock Key

Normally, to lock or unlock the printer menu, the UP and DOWN keys are pressed at the same time. The Set Lock Key parameter lets you choose different keys to lock or unlock the printer menu. You may choose almost any group of keys as the new lock and unlock keys. You cannot use the ENTER key or any key combinations which are already used for another function. There is no limit to how many keys you can select.

To set the new lock key, follow these steps:

1. Work your way through the configuration menu until the display reads "Set Lock Key" (follow the menu structure on page 281).
2. Press ENTER. The display reads, "Select a new lock key."
3. Press the combination of keys you want to be the new lock key. Make sure you press all keys selected at the same time.
4. If the selection is valid, the display will read, "Enter the new lock key again." If the selection is invalid, the display will read, "Invalid key selection." Return to step 2 and start over.
5. Press the same combination of keys a second time. If the new lock key combination is entered again correctly, the display will read, "Lock key has been changed." If it was entered incorrectly, the display will read "Verification failed." Start over at step 2.
6. After entering the new lock combination successfully, press the ON LINE key to put the printer back online.

NOTE: The new lock combination will remain even if the printer is powered off and back on.

Ribbon Action

- **Stop Ribbon End** (the default). Stops ribbon action when ribbon life reaches 0%.
- **Ignore Ribbon End**. When selected, the ribbon life display remains on the control panel, and the printer continues to monitor ink consumption.

Ink Saver Mode

The overall image density setting will be maintained at a lower level, equivalent to approximately 0.2 PCS below the default setting. The factory default setting is Disable. Select Enable and press the ENTER key to activate the Ink Saver Mode.

DIAGNOSTICS

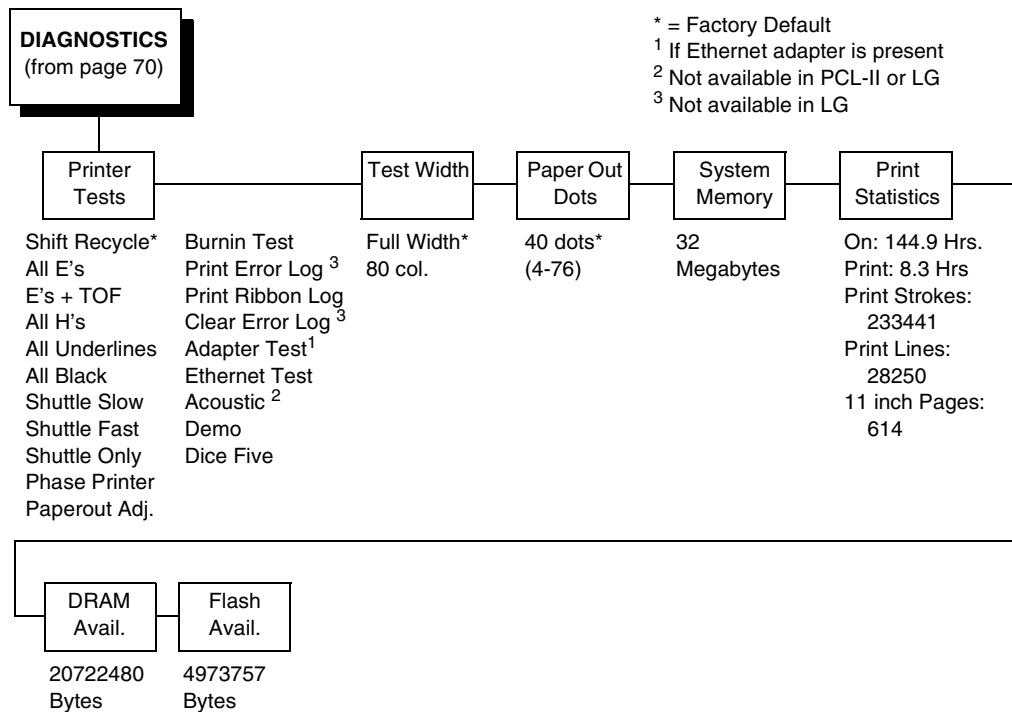

Test Width

Set this parameter to run the self-tests at full width or 80 columns.

Printer Tests

These tests are used to check the print quality and operation of the printer.

NOTE: Your authorized service representative will typically run the tests. They are described in more detail in the *Maintenance Manual*.

- **Shift Recycle.** A sliding alphanumeric pattern which identifies missing or malformed characters, improper vertical alignment, or vertical compression.
- **All E's.** A pattern of all uppercase E's which identifies missing characters, misplaced dots, smeared characters, improper phasing problems, or light/dark character variations.
- **E's + TOF.** A pattern of all E's followed by a form feed to the next page top-of-form, which identifies paper motion or feeding problems.
- **All H's.** A pattern of all uppercase H's used to detect missing characters, misplaced dots, smeared characters, or improper phasing.
- **All Underlines.** An underline pattern useful for identifying hammer bank misalignment.
- **All Black.** A condition where all dot positions are printed, creating a solid black band.
- **Shuttle Slow.** Verifies proper operation by exercising shuttle and ribbon motion at low speed.
- **Shuttle Fast.** Verifies proper operation by exercising shuttle and ribbon motion at fast speed.
- **Shuttle Only.** Exercises only the shuttle at fast speed.
- **Phase Printer.** Checks for wavy print. The initial phase value is set in the factory. Run the test and check the quality. (The phase value prints on the left margin.) If the print looks too wavy, change the Phase Value parameter while the test is running. While the phase printer test runs, press the DOWN key. To change the value, press the PREV or NEXT key until the desired value displays and then press ENTER.

- **Paperout Adj.** Verifies the current Paper Out Dots setting, which determines where the last line of text will print when there is a paper out condition. Setting this parameter correctly prevents printing on the platen.
- **Burnin Test.** Reserved for factory use.
- **Print Error Log.** Prints the current log of errors. Most non-routine faults (ribbon stall, voltage faults) are stored in the error log.
- **Print Ribbon Log.** Prints log of ribbons that have been used in the printer.
- **Clear Error Log.** Clears entries in the error log.
- **Adapter Test.** Prints the Ethernet adapter statistics stored on the Ethernet adapter (if present).
- **Ethernet Test.** Prints the Ethernet statistics stored on the Ethernet (if present).
- **Acoustics.** A particular test pattern that is used to measure acoustics.
- **Demo.** Demonstration of various print attributes.
- **Dice Five.** Pattern used to measure print density.

Paper Out Dots

CAUTION

Only authorized service representatives should set this parameter.

This parameter is used to adjust the paper out distance from the perforation; you can specify where the last line on the page will print when there is a paper out condition. Setting this parameter correctly prevents printing on the platen.

System Memory

Displays the amount of RAM installed.

Print Statistics

You can view various printer statistics and refer to them for preventive maintenance purposes. Printer statistics accumulate continuously; they do not reset when you turn off the printer. All of the printer statistics are set to zero at the factory after burn-in testing.

- **On.** The cumulative time in hours the printer has been powered on. The range is 0 to 30,000 hours.
- **Print.** The cumulative time in hours the printer has actually been printing. The range is 0 to 30,000 hours.
- **Print Strokes.** The cumulative number of back-and-forth shuttle strokes the printer has printed during normal printer operation. The range is 0 to 2,147,483,647 shuttle strokes.
- **Print Lines.** The cumulative number of lines the printer has printed. The range is 0 to 2,147,483,647 print lines.
- **11 inch Pages.** The cumulative number of pages the printer has printed. The range in print pages is 0 to 2,147,483,647 total inches of paper movement divided by 11.

DRAM Avail.

The number of volatile DRAM memory bytes available to the application for variable workspace and page rendering.

Flash Avail.

The number of non-volatile Flash memory bytes available for the printer Flash File System.

5

Interfaces

Overview

This chapter describes the host interfaces provided with the printer. The printer interface is the point where the data line from the host computer plugs into the printer. The interface processes all communications signals and data to and from the host computer. Plus, with the Auto Switching feature, you can configure the printer to accept several interfaces at the same time (see “Auto Switching Submenu” on page 86).

This chapter describes the interfaces provided with the printer.

Standard Host Interfaces:

- Centronics parallel
- IEEE 1284 parallel bidirectional
- High Speed Serial Port (RS-232/RS-422)

NOTE: RS-422 is optional.

Optional Host Interfaces:

- Coax / Twinax
- Dataproducts Long Lines
- Dataproducts parallel
- Ethernet 10/100BaseT

In addition to descriptions for the multi-line interfaces, this chapter also provides instructions for configuration of terminating resistors for the parallel interfaces.

Chapter 5 Dataproducts Parallel Interface

Dataproducts Parallel Interface

**Table 8. Dataproducts Parallel Interface Connector Pin Assignments
(with a 50-pin AMP HDH-20 Data Cable Connector)**

Input Signals		Output Signals		Miscellaneous	
Signal	Pin	Signal	Pin	Signal	Pin
DATA LINE 1	19	READY	22	CABLE VERIFY	45, 46
Return	3	Return	6		
DATA LINE 2	20	ONLINE	21	GROUND	39
Return	4	Return	5		
DATA LINE 3	1	DEMAND/DATA REQ.	23		
Return	2	Return	7		
DATA LINE 4	41	PARITY ERROR	27		
Return	40		11		
DATA LINE 5	34				
Return	18				
DATA LINE 6	43				
Return	42				
DATA LINE 7	36				
Return	35				
DATA LINE 8	28				
Return	44				
DATA STROBE	38				
Return	37				
PAPER INSTRUCTION	30				
Return	14				
BUFFER CLEAR	31				
Return	15				

NOTE: Pins not listed are not connected.

The length of the data cable from the host computer to the printer must not exceed 40 feet (12 meters).

Dataproducts Parallel Interface Signals

Data Lines 1 through 8. Provides eight standard or inverted levels from the host that specify character data, plot data, or a control code. Data Line 8 allows access to the extended ASCII character set. You can enable or disable this line via the Data Bit 8 parameter on the Dataproducts submenu (see page 94).

Data Strobe. Carries a high true pulse from the host when data is ready. The data strobe remains high until the Data Request line goes false. The active edge of the strobe signal can be configured as leading, middle (default), or trailing.

Paper Instruction (PI). Carries a DVFU signal from the host with the same timing and polarity as the data lines.

Ready. Carries a high true signal from the printer when AC power and DC voltages are present, paper is loaded properly, and the printer is not in a check condition.

Online. Carries a high true signal from the printer when the Ready Line is true and the ON LINE key on the control panel has been pressed. When the printer is in online mode, it may accept data from the host.

Demand/Data Request. Carries a high true signal from the printer when the printer is ready to accept character data from the host. This signal changes to false shortly after the leading edge of the data strobe signal.

Cable Verify. Two pins on the interface connector are jumpered together to allow the user to verify proper installation of the interface connector.

Buffer Clear. A high true level from the host to indicate the printer should perform a reboot.

Parity Error. Always carries a low false signal from the printer indicating there is no parity error.

Centronics Parallel Interface

Table 9. Centronics Interface Connector Pin Assignments

Input Signals		Output Signals		Miscellaneous	
Signal	Pin	Signal	Pin	Signal	Pin
DATA LINE 1 Return	2 20	ACKNOWLEDGE Return	10 28	CHASSIS GROUND	17
DATA LINE 2 Return	3 21	ONLINE Return	13 28	GROUND	30
DATA LINE 3 Return	4 22	FAULT Return	32 29	Spares	14
DATA LINE 4 Return	5 23	PAPER EMPTY Return	12 28	No Connection	34,35, 36
DATA LINE 5 Return	6 24	BUSY Return	11 29	+5 Volts	18
DATA LINE 6 Return	7 25				
DATA LINE 7 Return	8 26				
DATA LINE 8 Return	9 27				
DATA STROBE Return	1 19				
PAPER INSTRUCTION Return	15 29				
PRIME Return	31 30				

The length of the data cable from the host computer to the printer must not exceed 15 feet (5 meters).

Centronics Parallel Interface Signals

Data Lines 1 through 8. Provides eight standard or inverted levels from the host that specify character data, plot data, or a control code. Data Line 8 allows access to the extended ASCII character set. You may enable or disable this line via the Data Bit 8 parameter on the Centronics submenu (see page 91).

Data Strobe. Carries a low true, 100 ns minimum pulse from the host that clocks data into the printer.

Acknowledge. A low true pulse from the printer indicating the character or function code has been received and the printer is ready for the next data transfer.

Online. A high true level from the printer to indicate the printer is ready for data transfer and the ON LINE key on the control panel has been activated. When the printer is in online mode, it may accept data from the host.

Paper Empty (PE). A high true level from the printer to indicate the printer is in a paper empty or paper jam fault.

Busy. A high true level from the printer to indicate the printer cannot receive data.

Prime. A high true level from the host to indicate the printer should perform a warm start (printer is reset to the power-up configuration values).

Paper Instruction (PI). Carries a CVFU signal from the host with the same timing and polarity as the data line.

Fault. A low true level from the printer indicates a printer fault.

IEEE 1284 Parallel Interface

The 1284 supports three operating modes, which are determined by negotiation between the printer and the host.

Compatibility Mode

This mode provides compatibility with Centronics-like host I/O (see Table 10). Data is transferred from the host to the printer in 8-bit bytes over the data lines.

Compatibility Mode can be combined with Nibble and Byte Modes to provide bidirectional communication.

Nibble Mode

Eight bits equals one byte. When a byte of data is sent to the printer, the eight bits are sent over eight data lines.

Some devices cannot send data over their eight data lines. To bypass this, the 1284 permits data to be sent as half a byte over four status lines. (Half a byte equals one nibble.) Two sequential four-bit nibbles are sent over the lines.

Data is transferred from printer to host in four-bit nibbles over the status lines, and the host controls the transmission.

Byte Mode

The printer and host send data to each other along eight data lines (one bit per line).

If bidirectional communication is supported by the printer and the host, the host will take control of the data transfer.

Signals

Table 10 lists each of the signals associated with the corresponding pins on the 1284 interface. Descriptions of the signals follow.

Table 10. 1284 Signals

Pin	Source of Data	Type of Mode		
		Compatible	Nibble	Byte
1	Host	nStrobe	HostClk	Host/Clk
2	Host/Printer	Data 1 (LSB)		
3	Host/Printer	Data 2		
4	Host/Printer	Data 3		
5	Host/Printer	Data 4		
6	Host/Printer	Data 5		
7	Host/Printer	Data 6		
8	Host/Printer	Data 7		
9	Host/Printer	Data 8 (MSB)		
10	Printer	nAck	PtrClk	PtrClk
11	Printer	Busy	PtrBusy	PtrBusy
12	Printer	PError	AckDataReq	AckDataReq
13	Printer	Select	Xflag	Xflag
14	Host	nAutoFd	Host Busy	HostAck
15		Not Defined		
16		Logic Grid		
17		Chassis Grid		
18	Printer	Peripheral Logic High		

Chapter 5 IEEE 1284 Parallel Interface

Table 10. 1284 Signals (continued)

Pin	Source of Data	Type of Mode		
		Compatible	Nibble	Byte
19		Signal Ground (nStrobe)		
20		Signal Ground (Data 1)		
21		Signal Ground (Data 2)		
22		Signal Ground (Data 3)		
23		Signal Ground (Data 4)		
24		Signal Ground (Data 5)		
25		Signal Ground (Data 6)		
26		Signal Ground (Data 7)		
27		Signal Ground (Data 8)		
28		Signal Ground (PErrror, Select, nAck)		
29		Signal Ground (Busy, nFault)		
30		Signal Ground (nAutoFd, nSelectIn, nInit)		
31	Host	nInit		
32	Printer	NFault	nDataAvail	aDataAvail
33		Not Defined		
34		Not Defined		
35		Not Defined		
36	Host	nSelectIn	1284 Active	1284 Active

NOTE: The length of the data cable from the host computer to the printer should not exceed 32 feet (10 meters).

Host Clock / nWrite. Driven by host. Data transferred from host to printer. When printer sends data, two types are available. If Nibble mode, signal is set high. If Byte mode, signal is set low.

Data 1 through Data 8. These pins are host-driven in Compatibility mode and bidirectional in Byte mode. They are not used in Nibble mode. Data 1 is the least significant bit; Data 8 is the most significant bit.

Printer Clock / Peripheral Clock / Interrupt. Driven by the printer. A signal from the printer indicating the character or function code has been received and the printer is ready for the next data transfer.

Printer Busy / Peripheral Acknowledge / nWait. Driven by the printer. Indicates the printer cannot receive data. (Data bits 4 and 8 in Nibble mode.)

Acknowledge Data Request / nAcknowledge Reverse. Driven by the printer. Indicates the printer is in a fault condition. (Data bits 3 and 7 in Nibble mode.)

Xflag. Driven by the printer. A high true level indicating the printer is ready for data transfer and the printer is on line. (Data bits 2 and 6 in Nibble mode.)

Host Busy / Host Acknowledge / NDStrobe. Driven by the host. Activates auto-line feed mode.

Peripheral Logic High. Driven by the printer. When the line is high, the printer indicates all of its signals are in a valid state. When the line is low, the printer indicates its power is off or its signals are in an invalid state.

nReverse Request. Driven by the host. Resets the interface and forces a return to Compatibility mode idle phase.

nData Available / nPeripheral Request. Driven by the printer. Indicates the printer has encountered an error. (Data bits 1 and 5 in Nibble mode.)

1284 Active / nAStrobe. Driven by the host. A peripheral device is selected.

Host Logic High—Driven by the host. When set to high, the host indicates all of its signals are in a valid state. When set to low, the host indicates its power is off or its signals are in an invalid state.

nInit —Resets init interface from the host.

Terminating Resistor Configurations

The factory equips the printer with several resistors that are used for parallel interface configurations and are suitable for most applications. These 470 ohm pull-up and 1K ohm pull-down terminating resistors are located at RP1 and RP2, shown in Figure 24.

If the values of these terminating resistors are not compatible with the particular interface driver requirements of your host computer, you may need to install resistors with different pull-up and pull-down values.

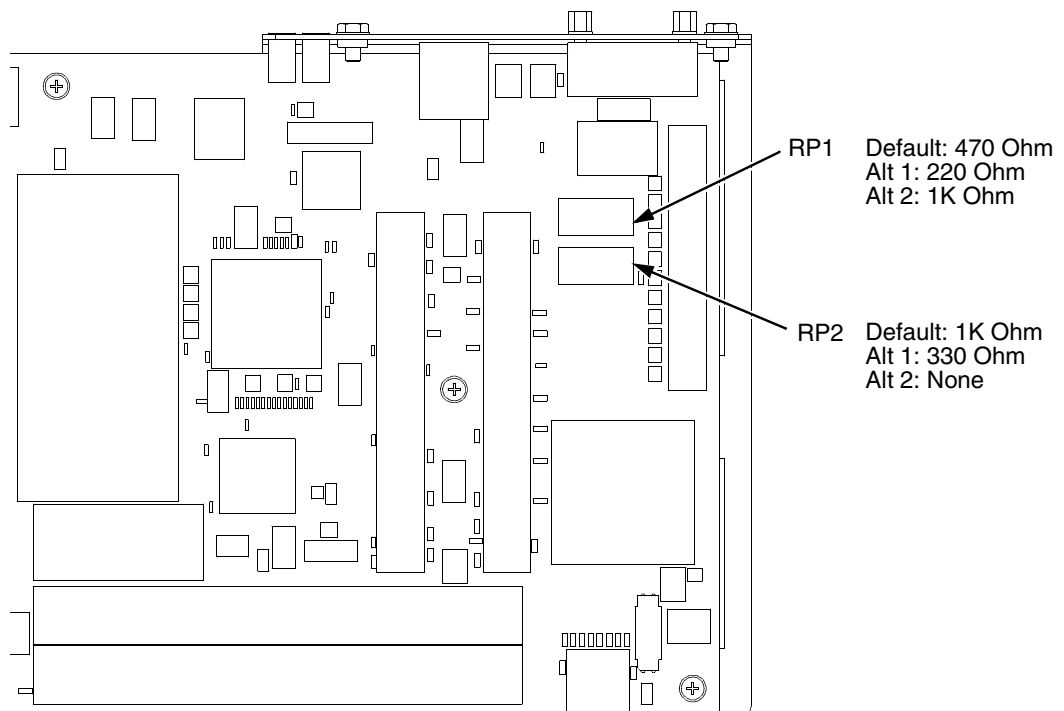

Figure 24. Resistor Locations

Terminating Resistor Configurations

The shipping kit for this printer includes 220 ohm pull-up and 330 ohm pull-down alternate terminating resistors. If you install the 220 ohm pull-up resistor, you must also install the 330 ohm pull-down resistor. Table 11 lists the three terminating resistor configurations you can install:

Table 11. Terminating Resistor Configurations

Configuration	Pull-Up (RP1)	Pull-Down (RP2)
Factory Default	470 ohm	1K ohm
Alternate 1	220 ohm	330 ohm
Alternate 2	1K ohm	none

Removal And Installation

The procedure for removing and installing terminating resistors is provided in your *Maintenance Manual*.

CAUTION This is an involved maintenance procedure. To avoid damage to the equipment, only a trained technician should perform this procedure.

RS-232 And RS-422 Serial Interfaces

NOTE: The RS-232 and RS-422 serial interface circuit characteristics are compatible with the Electronic Industry Association Specifications EIA-232-E and EIA-422-B.

The RS-232 and RS-422 serial interfaces enable the printer to operate with bit serial devices that are compatible with an RS-232 controller. The input serial data transfer rate (in baud) is selectable from the printer's control panel. Baud rates of 600, 1200, 2400, 4800, 9600, 19200, 38400, 57600, and 115200 baud rates are available.

NOTE: If you select a baud rate that is greater than 19200, you may need to use RS-422 to prevent data loss.

The length of the data cable from the host computer to the printer must not exceed 50 feet (15 meters) for RS-232 or 4000 feet (1220 meters) for RS-422. (A copper conductor, twisted-pair telephone cable with a shunt capacitance of 16 pF/foot [52.5 pF/meter] terminated in a 100 ohm resistive load must be used for the RS-422.)

RS-232

**Table 12. Standard 500, 1000, 1500 lpm Models
RS-232 Serial Interface Connector Pin Assignments**

Input Signals		Output Signals		Miscellaneous	
Signal	Pin	Signal	Pin	Signal	Pin
Receive Data (RXD)	3	Transmit Status & Control Data (TXD)	2	Chassis Ground	1
Clear To Send (CTS)	5	Request To Send (RTS)	4	Signal Ground	7
Data Set Ready (DSR)	6	Data Terminal Ready (DTR)	20		
Data Carrier Detect (DCD)	8				

Table 13. RS-232 Serial Interface Connector Pin Assignments

Input Signals		Output Signals		Miscellaneous	
Signal	Pin	Signal	Pin	Signal	Pin
Receive Data (RXD)	2	Transmit Status & Control Data (TXD)	3	Chassis/Signal Ground	5
Clear To Send (CTS)	8	Request To Send (RTS)	7		
Data Set Ready (DSR)	6	Data Terminal Ready (DTR)	4		
Data Carrier Detect (DCD)	1				

Receive Data (RXD). Serial data stream to the printer.

Transmit Data (TXD). Serial data stream from the printer for transmitting status and control information to the host. Subject to protocol selection.

Request To Send (RTS). Control signal from the printer. Subject to configuration.

Chapter 5 RS-232 And RS-422 Serial Interfaces

Clear To Send (CTS). Status signal to the printer indicating the host is ready to receive data/status signals from the printer.

Data Set Ready (DSR). Status signal to the printer indicating the host is in a ready condition.

Data Carrier Detect (DCD). Status signal to the printer. The ON condition is required for the printer to receive data.

Data Terminal Ready (DTR). Control signal from the printer. Subject to configuration.

RS-422

Table 14. PSA3 RS-422 Serial Interface Connector Pin Assignments

Input Signals		Output Signals		Miscellaneous	
Signal	Pin	Signal	Pin	Signal	Pin
- Receive Data (-RXD)	1	- Transmit Data (-TXD)	3	Chassis/Signal Ground	5
+ Receive Data (+RXD)	6	+ Transmit Data (+TXD)	8		

+RXD, -RXD. Serial data stream differentially received by printer.

+TXD, -TXD. Differentially driven serial data stream for transmitting status and control information to the host. Subject to protocol selection.

NOTE: \pm RXD and \pm TXD form signal and return paths of a differential line signal.

6

Reprogramming The Security Key

Reprogramming The Security Key

The security key on the PSA3 controller board can be reprogrammed with a Software Program Exchange (SPX) module. The SPX is an intelligent module that plugs into the debug port on the back of printers equipped with the PSA3 “Hurricane” controller board. The SPX is used only once; it automatically overwrites itself after successfully reprogramming a security key. This allows the end user or a service technician to enable features such as new emulations without having to remove covers and install a new security key on the controller board.

The SPX is used at power-up only and is not left in the printer during normal operation. Because it is a single-use disposable item the user is not required to return it to the vendor or manufacturer.

How To Program The Security Key

1. Power off the printer.
2. On cabinet models, open the rear door. On pedestal models, refer to Figure 25 to locate the debug port at the rear of the printer.
3. Insert the SPX into the debug port as shown.

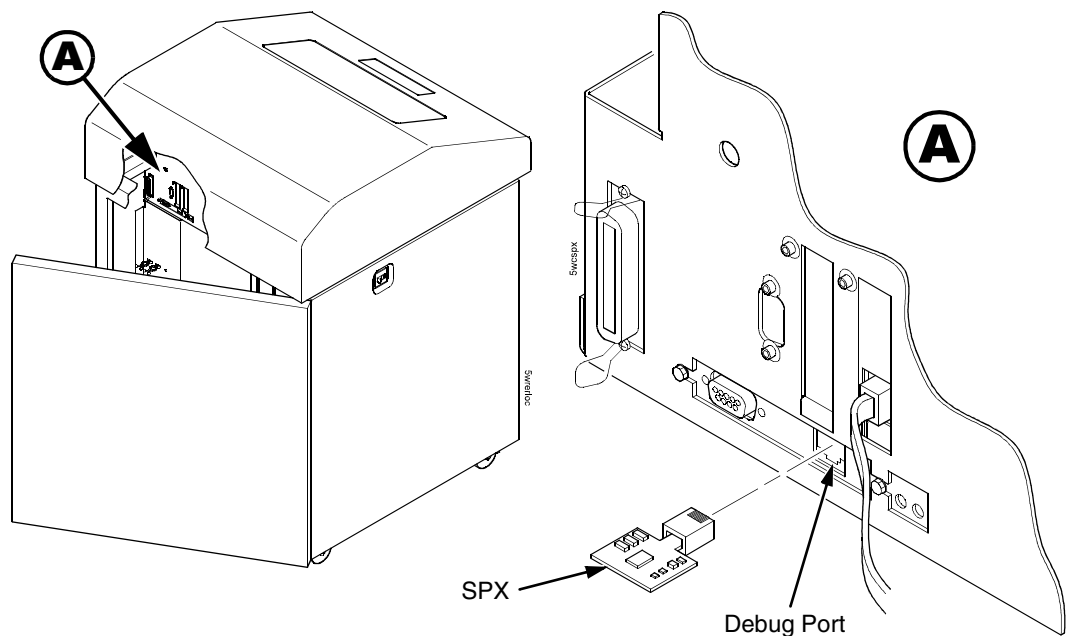

Figure 25. Inserting The SPX into the Debug Port

4. Power on the printer. The printer will begin its boot-up sequence.
5. When the printer detects a valid SPX, the control panel displays:
“NEW SPX DETECTED
PRESS ENTER”

NOTE: If an error message displays, find the message in the Message List in Chapter 7 and follow the troubleshooting instructions.

6. Press the **ENTER** key to activate the reprogramming sequence. The display will read:
“PROGRAMMING. PLEASE WAIT.”
7. When the security key is reprogrammed, the display will read:
“REMOVE USED SPX
THEN PRESS ENTER”
8. Remove the SPX from the debug port at the rear of the printer.

How To Program The Security Key

9. Press the **ENTER** key. The printer will reboot itself and you may resume normal printing.
10. You may need to download a new program file to use the new feature.
11. You may need to set additional menu parameters for any new features that have been added or enabled.

Chapter 6 Reprogramming The Security Key

7

Troubleshooting

Cleaning Requirements

Clean the printer every six months or after every 1000 hours of operation, whichever occurs first. If the printer is located in a dusty area or is used for heavy duty printing, clean it more often.

WARNING

Disconnect the power source before cleaning the printer.

Vor dem Säubern des Druckers ist die Netzverbindung zu unterbrechen.

Débranchez l'alimentation avant de nettoyer l'imprimante.

Desconecte la fuente de energía antes de limpiar la impresora.

Staccare la fonte di energia prima della pulitura della stampante.

Exterior Cleaning

Clean the outside of the cabinet with a soft, lint-free cloth and mild detergent soap. (Dishwashing liquid works well.) Do not use abrasive powders or chemical solvents. Clean the windows with plain water or mild window cleaner. Always apply the cleaning solution to the cloth; never pour cleaning solution directly onto the printer.

Interior Cleaning

Over time, particles of paper and ink accumulate inside the printers. This is normal. Paper dust and ink build-up must be periodically removed to avoid degraded print quality. Most paper dust accumulates around the ends of the platen and ribbon path.

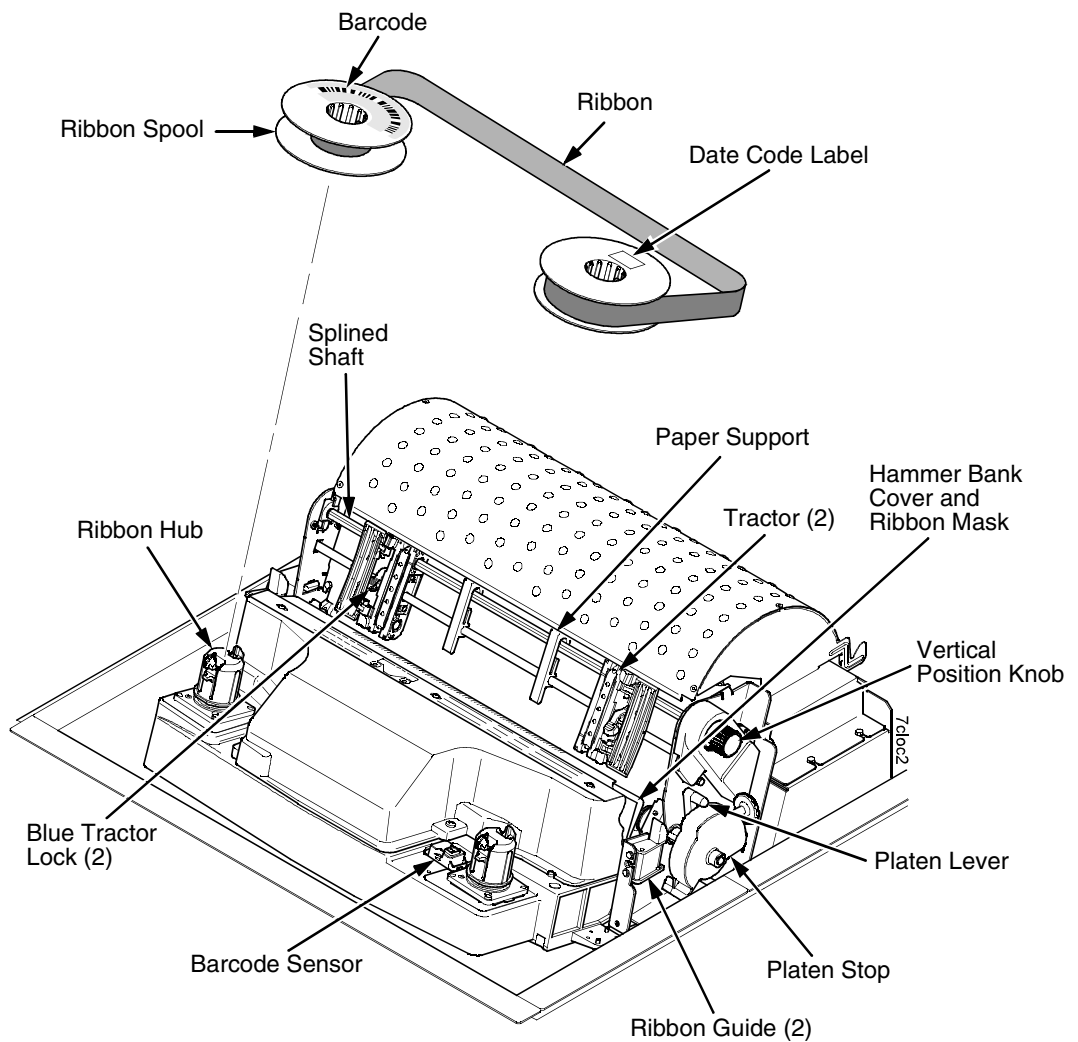

Figure 26. Interior Printer Components

To clean the interior of the printer perform the following steps.

1. Power off the printer and unplug the printer power cord.
2. Open the printer cover.
3. Fully raise the platen lever.
4. Unload the paper.
5. Unlatch the ribbon and ribbon spool and carefully lift them off the hubs.
6. Lift the ribbon out of the ribbon path.
7. Brush the paper dust and ribbon lint off the tractors, shuttle cover assembly, base casting, and ribbon guides with a soft-bristled, non-metallic brush (such as a toothbrush). Vacuum up the residue.

CAUTION Vacuum carefully around the hammer bank and surrounding area to avoid damage. To avoid corrosion damage, use only alcohol when cleaning the printer mechanical elements. Solutions used to clean mechanical elements must contain no water.

8. Wipe the splined shaft with a soft cloth.
9. Check the ribbon mask and hammer bank cover for bits of torn paper or ribbon lint.
10. Remove dust and ink from the platen using a soft cloth lightly moistened with anhydrous alcohol. (The platen is the thick silver bar behind the hammer bank cover that rotates when the platen lever is rotated.) Clean the ribbon guides.

CAUTION When cleaning the platen, be very careful not to get any alcohol in the hammer bank, because alcohol will cause severe damage to the hammer bank. Only a trained service technician should clean the shuttle assembly.

Chapter 7 Diagnosing Problems

11. Brush and vacuum the accumulated dust or residue inside the lower cabinet.
12. Wipe the lower cabinet interior with a clean, lint-free cloth dampened (not wet) with water and mild detergent or window cleaning solution. Dry the lower cabinet interior by wiping it down with a clean, lint-free cloth.
13. Install the ribbon and load paper.

Diagnosing Problems

This section is designed to help you fix problems which may arise with normal printer operation.

Bar Code Verification

The most important consideration when printing a bar code is to ensure that the bar code will be scanned properly. Incorporating a bar code quality procedure in the printing process is the best way to ensure that bar codes are being printed correctly. A properly implemented verification procedure will increase overall bar code quality, reduce waste from misprinted bar codes, and achieve high first-time read rates. A high first-time read rate is an increasingly important factor in newer, more efficient systems where manually entered data is not acceptable as a backup function. Verification also minimizes the costs of returned products due to poor reading or unaccountable bar codes.

RJS designs and manufactures the world's most complete line of bar code verification products, including their portable Inspector and Laser Inspector models, On-Line Inspector and AutoScan II series. For more information on RJS bar code verifiers, visit their web site at www.rjs1.com.

Printing A Hex Dump

A hex code printout (or hex dump) is a translation of all host interface data to its hexadecimal equivalent, listing all ASCII character data received from the host computer with their corresponding two-digit hexadecimal codes. Hex dumps are used to troubleshoot printer data reception problems.

Printable characters print as the assigned symbol; nonprintable characters are indicated by a period (.).

Figure 27 shows an example of a hex dump.

```

!##%&'()*+,-./ 20 21 22 23 24 25 26 27 28 29 2A 2B 2C 2D 2E 2F
0123456789:;<=>? 30 31 32 33 34 35 36 37 38 39 3A 3B 3C 3D 3E 3F
@ABCDEFGHIJKLMNO 40 41 42 43 44 45 46 47 48 49 4A 4B 4C 4D 4E 4F
PQRSTUVWXYZ[\]^_ 50 51 52 53 54 55 56 57 58 59 5A 5B 5C 5D 5E 5F
`abcdefghijklmno 60 61 62 63 64 65 66 67 68 69 6A 6B 6C 6D 6E 6F
pqrstuvwxyz{|}~ 70 71 72 73 74 75 76 77 78 79 7A 7B 7C 7D 7E 20
!##%&'()*+,-./0 21 22 23 24 25 26 27 28 29 2A 2B 2C 2D 2E 2F 30
123456789:;<=>@ 31 32 33 34 35 36 37 38 39 3A 3B 3C 3D 3E 3F 40
ABCDEFGHIJK...!##%& 41 42 43 44 45 46 47 48 0D 0A 21 22 23 24 25 26
'()*+,-./0123456 27 28 29 2A 2B 2C 2D 2E 2F 30 31 32 33 34 35 36
789:;<=>@ABCDEF 37 38 39 3A 3B 3C 3D 3E 3F 40 41 42 43 44 45 46
GHIJKLMNOPQRSTU 47 48 49 4A 4B 4C 4D 4E 4F 50 51 52 53 54 55 56
WXYZ[\]^_`abcdef 57 58 59 5A 5B 5C 5D 5E 5F 60 61 62 63 64 65 66
ghijklmnopqrst 67 68 69 6A 6B 6C 6D 6E 6F 70 71 72 73 74 75 76
uvwxyz{|}~!##%&' 77 78 79 7A 7B 7C 7D 7E 20 21 22 23 24 25 26 27
'()*+,-./0123456 28 29 2A 2B 2C 2D 2E 2F 30 31 32 33 34 35 36 37
89:;<=>@ABCDEF 38 39 3A 3B 3C 3D 3E 3F 40 41 42 43 44 45 46 47
HI...!##%&'()*+,- 48 49 0D 0A 22 23 24 25 26 27 28 29 2A 2B 2C 2D
./0123456789:;<= 2E 2F 30 31 32 33 34 35 36 37 38 39 3A 3B 3C 3D
>?@ABCDEFGHIJKLM 3E 3F 40 41 42 43 44 45 46 47 48 49 4A 4B 4C 4D
NOPQRSTUVWXYZ[\ 4E 4F 50 51 52 53 54 55 56 57 58 59 5A 5B 5C 5D
^_`abcdefghijklm 5E 5F 60 61 62 63 64 65 66 67 68 69 6A 6B 6C 6D
nopqrstuvwxyz{|} 6E 6F 70 71 72 73 74 75 76 77 78 79 7A 7B 7C 7D
~!##%&'()*+,-./ 7E 20 21 22 23 24 25 26 27 28 29 2A 2B 2C 2D 2E
/0123456789:;<= 2F 30 31 32 33 34 35 36 37 38 39 3A 3B 3C 3D 3E
?@ABCDEFGHIJK...## 3F 40 41 42 43 44 45 46 47 48 49 4A 0D 0A 23 24
%&'()*+,-./0123 25 26 27 28 29 2A 2B 2C 2D 2E 2F 30 31 32 33 34
56789:;<=>@ABCD 35 36 37 38 39 3A 3B 3C 3D 3E 3F 40 41 42 43 44
EFGHIJKLMNOPQRST 45 46 47 48 49 4A 4B 4C 4D 4E 4F 50 51 52 53 54
UVWXYZ[\]^_`abcd 55 56 57 58 59 5A 5B 5C 5D 5E 5F 60 61 62 63 64
efghijklmnopqrst 65 66 67 68 69 6A 6B 6C 6D 6E 6F 70 71 72 73 74
uvwxyz{|}~!##%& 75 76 77 78 79 7A 7B 7C 7D 7E 20 21 22 23 24 25
&'()*+,-./01234 26 27 28 29 2A 2B 2C 2D 2E 2F 30 31 32 33 34 35
6789:;<=>@ABCDE 36 37 38 39 3A 3B 3C 3D 3E 3F 40 41 42 43 44 45
FGHIJK...%&'()*+ 46 47 48 49 4A 4B 0D 0A 24 25 26 27 28 29 2A 2B
,-./0123456789: 2C 2D 2E 2F 30 31 32 33 34 35 36 37 38 39 3A 3B
<=>?@ABCDEFGHIJK 3C 3D 3E 3F 40 41 42 43 44 45 46 47 48 49 4A 4B
LMNOPQRSTUVWXYZ 4C 4D 4E 4F 50 51 52 53 54 55 56 57 58 59 5A 5B
\]^_`abcdefghijkl 5C 5D 5E 5F 60 61 62 63 64 65 66 67 68 69 6A 6B
lmnopqrstuvwxyz{ 6C 6D 6E 6F 70 71 72 73 74 75 76 77 78 79 7A 7B
}|}~!##%&'()*+ 7C 7D 7E 20 21 22 23 24 25 26 27 28 29 2A 2B 2C

```

Figure 27. Hex Dump Sample

Fault Messages

If a fault condition occurs in the printer, the status indicator on the control panel flashes on and off, and the message display indicates the specific fault. Fault messages are summarized in Table 15.

Displayed faults fall into one of two categories:

- Operator correctable
- Field service required

For the operator-correctable faults, follow the suggested solution in Table 15. After correcting the displayed fault, press the CLEAR key to clear the error message and status indicator and resume printing. If the fault message reappears, contact your authorized service representative.

NOTE: The *Maintenance Manual* provides more detailed information and procedures for resolving fault conditions. However, many of the procedures described there must be performed only by your authorized service representative.

Fault Messages Requiring Field Service Attention

If a fault is not correctable by the operator, the fault message is followed by an asterisk (*). This usually indicates that an authorized service representative is needed. You may try two steps to clear the fault before calling your authorized service representative:

1. Set the printer power switch to O (Off), wait 15 seconds, then turn the printer on again. Run your print job again. If the message does not appear, it was a false indication and no further attention is required.
2. If the message reappears, press the CLEAR key. If the message disappears, it was a false indication and no further attention is required. If the message reappears, call your authorized service representative.

Fault Messages

Table 15. LCD Message Troubleshooting Table

Displayed Message	Can User Correct?	Explanation	Solution
06 HOST REQUEST	Yes	Host attention message.	The host computer or printer controller requires attention.
08 HOLD PRINT TIMEOUT	Yes	Printer was offline more than 10 minutes, and the "Intervention Required" parameter is set to "Send to Host."	Press ON LINE to put printer in online state.
8.5V PWR FAIL*	No	Internal power failure.	Contact your authorized service representative. ¹
15 COMM CHECK	Yes	Line not active (twinax interface).	Check cable connection.
15V CTL FAIL*	No	Controller voltage failure.	Contact your authorized service representative. ¹
22 INVALID ADDR	Yes	Unit address not recognized by printer. (Twinax interface)	Ensure that printer address matches host setting.
23.5V CTL FAIL*	No	Controller voltage failure.	Contact your authorized service representative. ¹
31 PAPER OUT TIMEOUT	Yes	A timeout message is sent to the host if paper is not loaded 10 minutes after CLEAR was pressed to clear the paper out fault.	Load paper.

Chapter 7 Diagnosing Problems

Table 15. LCD Message Troubleshooting Table

Displayed Message	Can User Correct?	Explanation	Solution
32 PAPER JAM TIMEOUT	Yes	A timeout message is sent to the host if no paper motion has occurred for 10 minutes after CLEAR was pressed to clear the jam fault.	Clear paper jam and reload paper.
33 PLATEN OPEN TIMEOUT	Yes	Platen lever has been open for at least one minute.	Close platen lever.
34 RIBBON STALL TIMEOUT	Yes	In the CT emulation with a coax interface, the ribbon has not moved for 10 minutes after CLEAR was pressed to clear the ribbon drive fault.	Reload the ribbon.
48V PWR FAIL*	No	Internal power failure.	Contact your authorized service representative. ¹
A TO D OVERUN*	No	Fatal firmware error on controller board.	Contact your authorized service representative. ¹
ACCESS NULL PTR*	No	Fatal firmware error on controller board.	Contact your authorized service representative. ¹

Table 15. LCD Message Troubleshooting Table

Displayed Message	Can User Correct?	Explanation	Solution
ACTIVATE LOST	No	Printer detects twinax protocol communication errors.	The printer reports the error.
B10 ERROR: NO DRAM DETECTED*	No	SDRAM DIMM may not be properly installed.	Cycle power to see if the message clears, if not, contact your authorized service representative. ¹
B11 ERROR: RAM TEST FAILED*	No	RAM test failure. SDRAM DIMM may not be properly installed.	Cycle power to see if the message clears, if not, contact your authorized service representative. ¹
B12 ERROR: PROGRAM MISSING*	No	Program not downloaded to the printer.	Cycle power to see if the message clears, if not, contact your authorized service representative. ¹
B13 ERROR: NOT COMPATIBLE*	No	Attempting to download a program that is not intended for this printer.	Cycle power to see if the message clears, if not, contact your authorized service representative. ¹

Table 15. LCD Message Troubleshooting Table

Displayed Message	Can User Correct?	Explanation	Solution
B19 ERROR: DC RETURNED*	No	The boot code calls the DC (the printer software that runs on the PowerPC) and then the DC code should run and never return back to the boot code. If the DC code returns back to the boot code then this message will be displayed.	Cycle power to see if the message clears, if not, contact your authorized service representative. ¹
B20 STATUS :00% DOWNLOAD MODE	No	Status message informing the operator that software is being downloaded. Percentage figure indicates approximate amount loaded into the printer.	No action is required.
B21 STATUS: PRINTER RESET	No	Status message informing the operator that the printer is undergoing a system reset.	No action is required.
B22 ERROR: DECOMPRESS SIZE*	No	FLASH SIMM may not be properly installed.	Cycle power to see if the message clears, if not, contact your authorized service representative. ¹

Fault Messages

Table 15. LCD Message Troubleshooting Table

Displayed Message	Can User Correct?	Explanation	Solution
B23 ERROR: DECOMPRESS CKSUM*	No	FLASH SIMM may not be properly installed.	Cycle power to see if the message clears, if not, contact your authorized service representative. ¹
B30-STATUS: INITIALIZING	N/A	Status message informing the operator that software is being downloaded through one of the printer's I/O ports using the two-key download activation.	No action is required.
B35-STATUS: WAITING FOR EC STATUS	N/A	Waiting for EC/DC Powerup handshake.	No action is required.
B40 ERROR: SDRAM EEPROM CKSUM BAD*	No	SDRAM DIMM may not be properly installed.	Cycle power to see if the message clears, if not, contact your authorized service representative. ¹
B41 ERROR: DIM MEMORY NOT SDRAM*	No	SDRAM DIMM is not compatible with the computer. SDRAM DIMM may not be properly installed.	Cycle power to see if the message clears, if not, contact your authorized service representative. ¹
B42 ERROR: SDRAM ROWS NOT ALLOWED*	No	SDRAM DIMM is not compatible with the computer. SDRAM DIMM may not be properly installed.	Cycle power to see if the message clears, if not, contact your authorized service representative. ¹

Chapter 7 Diagnosing Problems

Table 15. LCD Message Troubleshooting Table

Displayed Message	Can User Correct?	Explanation	Solution
B43 ERROR: SDRAM TOO MANY BANKS*	No	SDRAM DIMM is not compatible with the computer. SDRAM DIMM may not be properly installed.	Cycle power to see if the message clears, if not, contact your authorized service representative. ¹
B44 ERROR: SDRAM NOT 64 BITS WIDE*	No	SDRAM DIMM is not compatible with the computer. SDRAM DIMM may not be properly installed.	Cycle power to see if the message clears, if not, contact your authorized service representative. ¹
B45 ERROR: SDRAM IS WRONG VOLTAGE*	No	SDRAM DIMM is not compatible with the computer. SDRAM DIMM may not be properly installed.	Cycle power to see if the message clears, if not, contact your authorized service representative. ¹
B46 ERROR: SDRAM HAS MIXED SIZES*	No	SDRAM DIMM is not compatible with the computer. SDRAM DIMM may not be properly installed.	Cycle power to see if the message clears, if not, contact your authorized service representative. ¹
B47 ERROR: SDRAM LARGER THAN 256M*	No	SDRAM DIMM is not compatible with the computer. SDRAM DIMM may not be properly installed.	Cycle power to see if the message clears, if not, contact your authorized service representative. ¹

Fault Messages

Table 15. LCD Message Troubleshooting Table

Displayed Message	Can User Correct?	Explanation	Solution
B49 ERROR: SDRAM # LOGICAL BANKS*	No	SDRAM DIMM is not compatible with the computer. SDRAM DIMM may not be properly installed.	Cycle power to see if the message clears, if not, contact your authorized service representative. ¹
B50 ERROR: SDRAM LOGIC COMB BANKS*	No	SDRAM DIMM is not compatible with the computer. SDRAM DIMM may not be properly installed.	Cycle power to see if the message clears, if not, contact your authorized service representative. ¹
B50 STATUS: XX% CLEAR FLASH	No	Emulation software successfully loaded in RAM. Old program being deleted from flash memory.	No action is required.
B51: ERROR SDA LINE STUCK LOW	No	Problem with I2C bus. Either SDRAM or PCI card shorting out the bus.	Contact your authorized service representative. ¹
B51 STATUS: XX% PROGRAMMING...	No	Status message file successfully loaded and is being saved in flash memory.	No action is required.
B55 STATUS: SEND PROGRAM TO EC	No	EC program downloaded and being programmed in EC.	No action is required.

Chapter 7 Diagnosing Problems

Table 15. LCD Message Troubleshooting Table

Displayed Message	Can User Correct?	Explanation	Solution
BARCODE DAMAGED Reverse Spools	Yes	Barcode detected, but not fully decoded.	If barcode appears damaged, reverse ribbon spools. If barcode label is present and undamaged, clean sensor lens using damp cloth or swab. Check that platen gap may be too tight constricting ribbon motion. Loosen gap if needed.
BARCODE MISSING Install New RBN	Yes	No barcode seen on the ribbon spool. Indicates missing label or damaged or dirty sensor.	If label is missing, install new ribbon. If barcode label is present and undamaged, clean sensor lens using damp cloth or swab.
BUFFER OVERRUN	Yes	Receive overrun (serial interface).	Check printer serial port configuration setup. Ensure the baud rate and data protocol match both host and printer settings.
CLEAR PAPER JAM	Yes	No paper motion.	Clear jam and reload paper. If this message recurs, contact your authorized service representative. ¹

Fault Messages

Table 15. LCD Message Troubleshooting Table

Displayed Message	Can User Correct?	Explanation	Solution
CLEARING PROGRAM FROM FLASH	No	Status message: emulation software successfully loaded into printer RAM and the checksum matched. The old program is now being deleted from flash memory.	No action is required.
CLOSE PLATEN	Yes	The platen lever is open.	Close the platen lever.
COIL HOT	No	One or more hammer coils are overheating.	Contact your authorized service representative. ¹
CTL VOLT FAIL*	No	Controller voltage failure.	Contact your authorized service representative. ¹
DIAGNOSTIC PASSED	No	Status message: the printer passed its memory and hardware initialization tests.	No action is required.
DO NOT POWER OFF	No	This is a standard warning message that displays while the printer is downloading software.	Do not power off the printer until downloading is complete.
DRVR CIR BAD*	No	Hammer coil count test failed.	Contact your authorized service representative. ¹

Chapter 7 Diagnosing Problems

Table 15. LCD Message Troubleshooting Table

Displayed Message	Can User Correct?	Explanation	Solution
E NET TEST UNAVAILABLE	Yes	The Ethernet PCBA did not initialize correctly.	Cycle power. Wait for “E Net Ready” to display, then retry operation. If the fault message appears again, contact your authorized service representative. ¹
ERROR: DC PROGRAM NOT VALID	Yes	The printer cannot find the data controller program or the validation checksum is corrupt.	Download the program again. If the message appears, replace the flash memory SIMM.
ERROR: DRAM AT ADDRESS XXXXXXXX	No	The printer found a defective memory location.	Contact your authorized service representative. ¹
ERROR: EC PROGRAM NOT VALID	No	The printer cannot find the engine controller program or the validation checksum is corrupt.	Contact your authorized service representative. ¹
ERROR: EC STOPPED AT STATE XXXX	No	XXXX is a number from 0000 to 0010. The Engine Controller has stopped and is in the state identified by the number displayed.	Contact your authorized service representative. ¹

Fault Messages

Table 15. LCD Message Troubleshooting Table

Displayed Message	Can User Correct?	Explanation	Solution
ERROR: FLASH DID NOT PROGRAM	Yes	The printer encountered an error trying to program flash memory.	Download the program again. If the message displays again, contact your authorized service representative. ¹
ERROR: FLASH NOT DETECTED	No	The printer could not find flash memory.	Contact your authorized service representative. ¹
ERROR: LOCKED SN=nnnnnnnnnnnnnn nnnnnnnn	No	nnnnnnnnnnnnnnnnnnnn is the serial number of the printer's security key. The SPX serial number does not match the printer's serial number and cannot be used with the printer.	Contact your authorized service representative. ¹
ERROR: NO DRAM DETECTED	No	The printer could not find any DRAM.	Contact your authorized service representative. ¹
ERROR: NVRAM FAILURE	No	The non-volatile SRAM on the controller board has failed.	Contact your authorized service representative. ¹

Chapter 7 Diagnosing Problems

Table 15. LCD Message Troubleshooting Table

Displayed Message	Can User Correct?	Explanation	Solution
ERROR OCCURRED FLUSHING QUEUES*	No	An interim message that displays while the printer discards host data it cannot use because a fault condition exists.	Contact your authorized service representative. ¹
ERROR: PROGRAM NEEDS MORE DRAM	No	The printer requires more DRAM to run the downloaded program.	Contact your authorized service representative. ¹
ERROR: PROGRAM NEEDS MORE FLASH	No	The printer requires more flash memory to run the downloaded program	Contact your authorized service representative. ¹
ERROR: PROGRAM NOT COMPATIBLE	Yes	The printer is not compatible with the downloaded program.	Use the correct emulation software options(s) for this printer model.
ERROR: PROGRAM NOT VALID	Yes	The printer does not see a program in flash memory.	There is no program in printer memory. Download the emulation.
ERROR: SECURITY KEY NOT DETECTED	No	The security key is not present or failed.	Contact your authorized service representative. ¹
ERROR: SHORT AT ADDRESS XXXX	No	Hardware failure in SDRAM or controller circuitry.	Contact your authorized service representative. ¹

Fault Messages

Table 15. LCD Message Troubleshooting Table

Displayed Message	Can User Correct?	Explanation	Solution
ERROR: WRITING TO FLASH	No	Hardware or software fault in flash memory.	Contact your authorized service representative. ¹
ERROR: WRONG CHECKSUM	No	The printer received the complete program but the checksum did not match.	Contact your authorized service representative. ¹
ERROR: WRONG OEM OR PRINTER TYPE	No	The SPX inserted in the debug port is not intended for this model printer or this OEM.	Contact your authorized service representative. ¹
ETHERNET ADAPTER BEING INITIALIZED	N/A	Status message indicating that the Network Interface Card is processing the boot procedure.	No action is required.
ETHERNET DETECTED	N/A	Status message indicating that the Network Interface Card has established connection.	No action is required.
EXCESS RBN WEAR Install New RBN	Yes	Displayed when ribbon reaches end of life	Install a new ribbon.

Table 15. LCD Message Troubleshooting Table

Displayed Message	Can User Correct?	Explanation	Solution
EXHAUST FAN FLT (Cabinet model only)	Yes	Sensors cannot detect current in fan circuit.	Power off the printer and remove the paper path (see <i>Maintenance Manual</i>). Check that the fan cable connector is connected. Check for obstruction of vents and fan airway, and remove any obstructions. Check for items beneath the printer blocking cabinet vents. Power back on the printer. If this message appears again, contact your authorized service representative. ¹
FIRMWARE ERROR*	No	Application software tried to perform an illegal printer function or damaged memory detected on board.	Contact your authorized service representative. ¹
FM HEADER ERROR*	No	Applications software has violated header parameters.	Contact your system administrator.
FRAMING ERROR	Yes	Serial framing error (serial interface).	Check your printer serial interface parameter settings; if necessary, adjust them so that they match the settings of the attached host.

Fault Messages

Table 15. LCD Message Troubleshooting Table

Displayed Message	Can User Correct?	Explanation	Solution
FREEFORM OFF	Yes	A control panel key is stuck in the down position.	Press the key again.
FREEFORM ON: OFF HOLD KEY @ PWRUP	No	This message appears if the freeform feature is enabled. This feature is for manufacturing use only and is never used by the customer or field maintenance personnel.	Contact your authorized service representative. ¹
GRF CHK ERROR PRESS STOP	Yes	Printer has received a non-printable character.	Press CLEAR and then ON LINE.
HAM. COIL OPEN*	No	Electrical malfunction of one or more hammer coils.	Contact your authorized service representative. ¹
HAMMER COIL BAD* #, #, #, ...etc	No	Hammer coil # failed current test at power up.	Contact your authorized service representative. ¹
HB NOT INSTALLD*	No	Self-test does not detect hammer coils.	Contact your authorized service representative. ¹

Chapter 7 Diagnosing Problems

Table 15. LCD Message Troubleshooting Table

Displayed Message	Can User Correct?	Explanation	Solution
HMR BANK FAN FLT	Yes	Sensors cannot detect current in fan circuit.	Check that fan cable is connected. Check for obstruction of vents and fan airway; remove any obstructions. Check for items beneath the printer blocking cabinet vents. Power back on the printer. If this message recurs, contact your authorized service representative. ¹
ILL EXT BUS ACC*	No	Fatal firmware error on controller board.	Contact your authorized service representative. ¹
ILLGL OPR ACCSS*	No	Fatal firmware error on controller board.	Contact your authorized service representative. ¹
INCOMPAT E-NET	Yes	Incompatible network interface card (NIC) is installed.	Install a compatible NIC to the printer then reboot. If this message still appears, contact your authorized service representative. ¹
INTAKE FAN FAULT	Yes	Sensors cannot detect current in fan circuit.	See description for HMR BANK FAN FLT.

Table 15. LCD Message Troubleshooting Table

Displayed Message	Can User Correct?	Explanation	Solution
INTERRUPT UNUSED VECTOR 00	No	The controller board receives an interrupt it does not understand.	Cycle power. If this message occurred once and never again, you can ignore it. If the message reappears or appears consistently, contact your authorized service representative. ¹
INVALID ACTIVATE	No	Printer detects twinax protocol communication errors.	The printer reports the error.
INVALID COMMAND	No	Printer detects twinax protocol communication errors.	The printer reports the error; host action is required.
LO DRV. SHORT *	No	Circuit(s) on the hammer bank or in the hammer bank power cable shorted to ground.	Contact your authorized service representative. ¹
LOAD PAPER	Yes	Printer is out of paper.	Load paper.
LOADING PROGRAM FROM PORT XX%	No	Status message: the new emulation program is loading into printer RAM. XX% indicates how much of the program has loaded.	No action is required.

Chapter 7 Diagnosing Problems

Table 15. LCD Message Troubleshooting Table

Displayed Message	Can User Correct?	Explanation	Solution
LOADING PROGRAM INTO FLASH	No	The printer has deleted the previous program from flash memory and is loading the new program into flash memory.	No action is required.
NEW SPX DETECTED PRESS ENTER	No	The printer detects an SPX installed at the debug port and the SPX is valid for the printer.	Contact your authorized service representative. ¹
NON VOLATILE MEMORY FAILED	No	The flash memory is defective.	Contact your authorized service representative. ¹
OLD RIBBON Install New RBN	Yes	Ribbon was previously declared end of life on the installed machine.	Install a new ribbon.
ON LINE	N/A	Printer state message: printer is online and in communication with host.	No action is required.
ONLINE 28 CU NOT ENAB	Yes	Poll timeout error. The printer was not polled for one minute. (Coax interface.)	Check cable connection and host system.
ONLINE 8344 FAILED*	No	Link-level code test detects hardware failure.	Contact your authorized service representative. ¹

Fault Messages

Table 15. LCD Message Troubleshooting Table

Displayed Message	Can User Correct?	Explanation	Solution
ONLINE CU TIMED OUT	Yes	Enable poll timeout. The printer was not enabled for one minute. (Coax interface)	Check cable connection and host system.
PAP BAD TABLE*	No	Fatal firmware error on controller board.	Contact your authorized service representative. ¹
PAP BSY TOO LNG*	No	Fatal firmware error on controller board.	Contact your authorized service representative. ¹
PAP FIFO OVERFL*	No	Fatal firmware error on controller board.	Contact your authorized service representative. ¹
PAP FIFO UNDRFL*	No	Fatal firmware error on controller board.	Contact your authorized service representative. ¹
PAP ILLGL ST*	No	Fatal firmware error on controller board.	Contact your authorized service representative. ¹
PAP INCMPL ENER*	No	Fatal firmware error on controller board.	Contact your authorized service representative. ¹
PAP INVLD CMD*	No	Fatal firmware error on controller board.	Contact your authorized service representative. ¹
PAP INVLD PARM*	No	Fatal firmware error on controller board.	Contact your authorized service representative. ¹

Chapter 7 Diagnosing Problems

Table 15. LCD Message Troubleshooting Table

Displayed Message	Can User Correct?	Explanation	Solution
PAP NOT SCHED*	No	Fatal firmware error on controller board.	Contact your authorized service representative. ¹
PAP NT AT SPEED*	No	Fatal firmware error on controller board.	Contact your authorized service representative. ¹
PAP UNEXP INT*	No	Fatal firmware error on controller board.	Contact your authorized service representative. ¹
PARAMETER ERROR*	No	Illegal parameter value received in command code.	Contact your system administrator.
PARITY ERROR	Yes	Parity error (serial interface)	Check your printer serial interface parameter settings; if necessary, adjust them so that they match the settings of the attached host.
PLAT INV CMD*	No	Fatal firmware error on controller board. Platen Invalid Command.	Contact your authorized service representative. ¹
PLAT INV PARM*	No	Fatal firmware error on controller board. Platen Invalid Parameter.	Contact your authorized service representative. ¹
PLAT INV STATE*	No	Fatal firmware error on controller board. Platen Invalid State.	Contact your authorized service representative. ¹

Fault Messages

Table 15. LCD Message Troubleshooting Table

Displayed Message	Can User Correct?	Explanation	Solution
PLEASE WAIT... RESET IN PROGRESS	N/A	The printer finished loading the program into flash memory and is automatically resetting itself.	No action is required.
POWER SAVER MODE	N/A	Status message: printer is in low-energy idle state, all fans and higher voltages are off, only +5Vdc logic circuits are active.	No action is required.
POWER SUPPLY HOT	Yes	Power supply sensors report high temperatures.	Check printer environment. If hot or dusty, relocate printer. Contact your authorized service representative if this occurs frequently. ¹
PRINTER HOT	Yes	Controller board sensors report high temperatures on the board.	Check printer environment. If hot or dusty, relocate printer. Contact your authorized service representative if this occurs frequently. ¹
PRINTER UNDER REMOTE CONTROL	Yes	Another user is accessing the printer remotely with the remote management software utility.	Wait until the remote user has finished their remote management session, or press any key to disable the Printer Manger and gain control of the printer.

Chapter 7 Diagnosing Problems

Table 15. LCD Message Troubleshooting Table

Displayed Message	Can User Correct?	Explanation	Solution
PROTECTED INSTR*	No	Fatal firmware error on controller board.	Contact your authorized service representative. ¹
PWR SUPP VOLT *	No	Power supply failed.	Replace power supply board.
QUEUE OVERRUN	No	In CT twinax emulation, the print buffer has overflowed.	Contact your authorized service representative. ¹
RBN SENSOR ERROR See User Manual	No	Failure of the barcode reader sensor.	Contact your authorized service representative. ¹
REMOVE USED SPX THEN PRESS ENTER	No	Status message: An SPX is depleted because it has successfully reprogrammed the security key on the controller board.	Contact your authorized service representative. ¹
RESTORING BOOT CODE	No	Normal download initialization message.	No action is required.
RIB INVLD CMD*	Yes	Ribbon Invalid Command. Firmware error on the controller board.	Cycle power. Run the print job again. If the message appears, download the emulation software again. If the message appears again, contact your authorized service representative. ¹

Fault Messages

Table 15. LCD Message Troubleshooting Table

Displayed Message	Can User Correct?	Explanation	Solution
RIB INVLD STATE*	No	Ribbon Invalid State.	Contact your authorized service representative. ¹
RIBBON DRIVE	No	The controller board does not detect a ribbon drive motor.	Contact your authorized service representative. ¹
RIBBON UNDER 2% Change RBN Soon	Yes	Message is displayed when ribbon life reaches 2% level.	Install a new ribbon.
RBN AT END POINT Change Ribbon	Yes	Software has determined that the ribbon life is at end point.	Install a new ribbon.
RIBBON NOT RECOGNIZED	Yes	The printer does not detect correct ribbon type.	Use the ribbons specified for the printer.
RIBBON STALL	Yes	The controller board does not detect ribbon movement.	Check the ribbon path for jams; if necessary, install a new ribbon.
SCS COMMAND ERROR*	No	Printer received undefined control character.	Contact your system administrator.
SECURITY CODE VIOLATION*	No	Security code of PAL on controller board does not match code of firmware on the controller board.	Contact your authorized service representative. ¹

Chapter 7 Diagnosing Problems

Table 15. LCD Message Troubleshooting Table

Displayed Message	Can User Correct?	Explanation	Solution
SECURITY KEY NOT DETECTED	No	The security key is not present or has failed.	Contact your authorized service representative. ¹
SENDING PROGRAM TO EC PROCESSOR	No	Status message: the printer is loading the engine controller program into the engine controller.	No action is required.
SHUTL INV CMD*	No	Fatal firmware error on controller board.	Contact your authorized service representative. ¹
SHUTL INV PARM*	No	Fatal firmware error on controller board.	Contact your authorized service representative. ¹
SHUTL OVR SPEED*	No	The shuttle is running over speed.	Contact your authorized service representative. ¹
SHUTTLE JAM	Yes	No shuttle movement or shuttle moving at wrong speed.	Check for obstruction to shuttle, a twisted ribbon, or platen lever closed too tightly. If fault source is not apparent, contact your authorized service representative. ¹

Fault Messages

Table 15. LCD Message Troubleshooting Table

Displayed Message	Can User Correct?	Explanation	Solution
SHUTTLE STALL	Yes	The shuttle is not moving.	Set the platen lever to match the thickness of paper, but not too tightly. Check and adjust the platen gap. Inspect the ribbon mask for deformation that snags and interferes with shuttle movement. If fault source is not apparent, contact your authorized service representative. ¹
SOFTWARE ERROR* CYCLE POWER	No	Application software tried to perform illegal printer function, or damaged logic circuits found on controller board.	Contact your authorized service representative. ¹
SPX FOUND, ERROR: KEY NOT DETECTED	No	The controller board does not have a security key.	Contact your authorized service representative. ¹
SPX NOT NEEDED OPTIONS ENABLED	No	Options included on the SPX are already installed on the host printer.	Contact your authorized service representative. ¹
STACK OVERFLOW*	No	Fatal firmware error on controller board.	Contact your authorized service representative. ¹
STACK UNDERFLOW*	No	Firmware error on the controller board.	Contact your authorized service representative. ¹

Chapter 7 Diagnosing Problems

Table 15. LCD Message Troubleshooting Table

Displayed Message	Can User Correct?	Explanation	Solution
STACKER FAULT	Yes	Stacker is not functioning correctly.	Check for obstructions in the stacker area. If fault persists, contact your authorized service representative. ¹
STACKER FULL	Yes	Power stacker is full of paper.	Remove paper.
STACKER JAM	Yes	This message is triggered if there is paper inside the throat of the stacker elevator, but the elevator is not moving.	1. Open the cabinet rear door and check for obstructions preventing elevator movement. Remove any obstructions. 2. Run the print job again. If the message appears again, contact your authorized service representative. ¹
TABLE MISMATCH DOWNLOAD AGAIN	No	Indicates that the software update has failed and should be reloaded.	Contact your authorized service representative. ¹
TCB CORRUPTED*	No	Fatal firmware error on controller board.	Contact your authorized service representative. ¹
TCP PORT BUSY	Yes	Error message reported by the Printer Manager when ethernet interface option is installed.	Refer to the <i>Printronix P7000 PSA3 Printers Maintenance Manual</i> .

Fault Messages

Table 15. LCD Message Troubleshooting Table

Displayed Message	Can User Correct?	Explanation	Solution
UNDEF INTERRUPT*	No	Fatal firmware error on controller board.	Contact your authorized service representative. ¹
UNDFNED OP CODE*	No	Fatal firmware error on controller board.	Contact your authorized service representative. ¹
UNKNOWN RBN1 Install New RBN	Yes	Ribbon was not a Printronix coded barcode.	Install a new ribbon.
UNKNOWN RBN2 Install New RBN	Yes	Ribbon not authorized.	Install a new ribbon.
UP DRV. SHORT*	No	Hammer drive circuits on the boards shorted to ground.	Cycle power to see if the message clears, if not, contact your authorized service representative. ¹
WAITING FOR ETHERNET ADAPTER	N/A	Appears when the printer is first powered on if the optional Network Interface Card is installed.	No action is required.
<p>¹ Before contacting an authorized service representative, power off the printer, wait 15 seconds, then power it back on and rerun your print job. If the message reappears, press CLEAR. If the fault message still displays, then contact your authorized service representative.</p>			

Chapter 7 Diagnosing Problems

A

Printer Specifications

Ribbon Specifications

Standard Ribbons	Part Number
P7000 Ultra Capacity (recommended for most text and barcode OCR)	179499-001
P7000 High Label (recommended for coated or shiny label stock)	179488-001
Specialty Ribbons	
P7000 Red Ribbon	179490-001
P7000 Blue Ribbon	179491-001
P7000 Green Ribbon	179492-001
P7000 Security Ribbon	179493-001
P7000 Quick Dry Ribbon	179494-001
P7000 Tamper Evident	179496-001
P7000 UV Ribbon	179497-001
P7000 Laundry Ribbon	179498-001

Paper Specifications

Type:	Edge-perforated, fan-fold, 3 to 17 inches (7.62 to 43.18 cm) wide, 2 to 12 inches (5.08 to 30.48 cm) long. SureStak Power Stacker option works with forms 5 to 12 inches (12.7 to 30.48 cm) long and up to 16 inches (41 cm) wide without the paper tent or 15.5 inches (39.5 cm) wide with the paper tent installed.
Thickness:	Single-part: 15 to 100 pound (6.80 to 45.36 kg) stock; Multi-part: 1- to 6-part forms (maximum 12 lb [5.44 kg] ply of upper plies)
Sheet Thickness:	0.025 inch (0.064 cm) maximum
Drive:	Adjustable tractors (6-pin engagement)

Labels

- On Backing:** One-part continuous perforated fanfold back form. Labels must be placed at least 1/6 inch (0.42 cm) from the fan-fold perforation. Backing adhesive must not be squeezed out during printing.
- Sheet Size:** 3 to 17 inches (7.62 to 43.18 cm) wide, including the two standard perforated tractor feed strips. A maximum sheet length of 16 inches (40.64 cm) between top and bottom perforations.
- NOTE:** A 16 inch rear door is needed for the cabinet model.
Power Paper Stacker option is 5 to 12 inches (12.7 to 30.48 cm) long.
- Thickness:** Not to exceed 0.025 inch (0.064 cm) (including backing sheet)

Appendix A Printer Weight And Dimensions

Printer Weight And Dimensions

Cabinet Type	Dimensions			Weight	
	Height	Width	Depth	Unpacked	Packaged
Floor Cabinet	42.5 inches	27 inches	29 inches*	225 lbs.	285 lbs.*
Pedestal	35 inches*	26 inches	21 inches	105 lbs.**	115 lbs.**

* With a power stacker, the weight increases by 21 lbs. and the depth increases by 4.75 inches for a deeper rear door.

** With the ZTP option, the weight increases by 12 lbs. and the height is increased by 7 inches.

Environmental Characteristics

Temperature:

Operating: 50° to 104° F (10° to 40° C) up to 5000 feet (1524 meters) 50° to 90° F (10° to 32° C) up to 8000 feet (2438 meters)

Storage: -40° to 158° F (- 40° to 70° C)

Relative Humidity

Operating: 15% to 80% (noncondensing)

Storage: 15% to 90% (noncondensing)

Acoustic Noise Level

Acoustic Noise Levels per ISO 9296	Cabinet Models	Pedestal Models
Printing	50 dB (500 lpm/1000 lpm) 52 dB (1500 lpm) 54 dB (2000 lpm)	65 dB 65 dB NA NA
	6.8 Bel	8.0 Bel
Standby	48 dB	50 dB
	6.3 Bel	6.5 Bel
Geraeuschemission nach ISO 9296		
Druckend	52 dB 52 dB (1500 lpm) 54 dB (2000 lpm)	65 dB 65 dB NA NA
	6.8 Bel	8.0 Bel
Betriebsbereit	48 dB	50 dB
	6.3 Bel	6.5 Bel

Energy Star

The printers described in this *User's Manual* comply with the requirements of the ENERGY STAR[®] Office Equipment Program of the U.S. Environmental Protection Agency.

When in the reduced-power idle state, the printer displays "Power Saver Mode."

Appendix A Electrical Characteristics

Electrical Characteristics

	Voltage (+/-10%)	Freq (+/-10%)	Amps	Watts	BTU/Hr
P7005	AC 100-120V	50-60 Hz	3A	275W	940
	AC 200-240V	50-60 Hz	1.5A	275W	940
P7010	AC 100-120V	50-60 Hz	3.5V	300W	1025
	AC 200-240V	50-60 Hz	1.6A	300W	1025
P7015	AC 100-120V	50-60 Hz	4.5A	430W	1469
	AC 200-240V	50-60 Hz	1.9A	430W	1469
P7205	AC 100-120V	50-60 Hz	3.5A	350W	1195
	AC 200-240V	50-60 Hz	1.6A	350W	1195
P7210	AC 100-120V	50-60 Hz	3.5A	350W	1195
	AC 200-240V	50-60 Hz	1.6A	350S	1195
P7215	AC 100-120V	50-60 Hz	5A	460W	1571
	AC 200-240V	50-60 Hz	2A	460W	1571
P7220	AC 100-120V	50-60 Hz	5.5A	540W	1844
	AC 200-240V	50-60 Hz	2.1A	540W	1844

The above values are calculated while printing 136 column, all upper case high speed "E's". The stand-by (Energy Saver mode) wattage is 28W (96 BTU/Hr) for all models.

Interfaces

Type:	Standard:	IEEE 1284 Parallel, Centronics Parallel, RS-232 serial, Dataproducts Parallel
	Optional:	Coax, Twinax, RS-422 serial, Ethernet 10/100Base-T.
Logic Levels:		TTL/EIA [®] -232E/EIA-422B
Transfer Rates:		Up to 200 Kilobytes on parallel interface. Up to 19.2K baud on RS-232 serial interface. Up to 115.2K baud on RS-422 serial interface

Printing Rates

The printing speed of text is measured in lines per minute (lpm) and is a function of the selected font and the vertical dot density. Printing speed is independent of the number of characters configured in the character set repertoire. Print rates for lines containing attributes such as bold or emphasized printing, superscripts, subscripts, or elongated attributes will decrease to not less than half the rates of the font without such attributes. The exact print rate of lines containing these attributes depends on the specific print job, but software maximizes the throughput by dynamically determining which dot rows contain adjacent dots and must be printed in two strokes.

The reverse paper feed capability allows the printing of multiple densities on a single line. This is useful in printing forms and text together or in mixing different fonts on a print line. Use of multiple densities and reverse paper feed also affects throughput.

Appendix A Printing Rates

B

ASCII Character Set

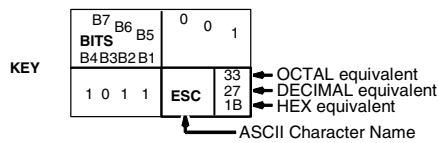

B7 BITS	B6	B5	0 0 0		0 0 1		0 1 0		0 1 1		1 0 0		1 0 1		1 1 0		1 1 1				
			COLUMN 0	1	2	3	4	5	6	7											
B4	B3	B2	B1	ROW																	
0	0	0	0	NUL	DLE	SP			@	P	\	p									
0	0	0	1	SOH	DC1 (XON)	!		A	Q	a		q									
0	0	1	0	STX	DC2	"		B	R	b		r									
0	0	1	1	ETX	DC3 (XOFF)	#		C	S	c		s									
0	1	0	0	EOT	DC4	\$		D	T	d		t									
0	1	0	1	ENQ	NAK	%		E	U	e		u									
0	1	1	0	ACK	SYN	&		F	V	f		v									
0	1	1	1	BEL	ETB	'		G	W	g		w									
1	0	0	0	BS	CAN	(H	X	h		x									
1	0	0	1	HT	EM)		I	Y	i		y									
1	0	1	0	LF	SUB	.	:	J	Z	j		z									
1	0	1	1	VT	ESC	+	;	K	[k		{									
1	1	0	0	FF	FS	,	<	L	\	l											
1	1	0	1	CR	GS	-	=	M]	m		}									
1	1	1	0	SO	RS	.	>	N	^	n		~									
1	1	1	1	SI	US	/	?	O	_	o		DEL									

Appendix B



C

Communication Notices

Notices

This information was developed for products and services offered in the U.S.A.

Printronix may not offer the products, services, or features discussed in this document in other countries. Consult your Printronix representative for information on the products and services currently available in your area. Any reference to an Printronix product, program, or service is not intended to state or imply that only that Printronix product, program, or service may be used. Any functionally equivalent product, program, or service that does not infringe any Printronix intellectual property rights may be used instead. However, it is the user's responsibility to evaluate and verify the operation of any non-Printronix product, program, or service.

Printronix may have patents or pending patent applications covering subject matter described in this document. The furnishing of this document does not give you any license to these patents. You can send license inquires, in writing, to:

Printronix, Inc.
14600 Myford Road
P.O. Box 19559
Irvine, CA 92623-9559 U.S.A.

Appendix C Notices

The following paragraph does not apply to the United Kingdom or any other country where such provisions are inconsistent with local law:

PRINTRONIX PROVIDES THIS PUBLICATION “AS IS” WITHOUT WARRANTY OF ANY KIND, EITHER EXPRESS OR IMPLIED, INCLUDING, BUT NOT LIMITED TO, THE IMPLIED WARRANTIES OF NON-INFRINGEMENT, MERCHANTABILITY OR FITNESS FOR A PARTICULAR PURPOSE. Some states do not allow disclaimer of express or implied warranties in certain transactions, therefore, this statement may not apply to you.

This information could include technical inaccuracies or typographical errors. Changes are periodically made to the information herein; these changes will be incorporated in new editions of the publication. Printronix may make improvements and/or changes in the product(s) described in this publication at any time without notice.

Any references in this information to non-Printronix Web sites are provided for convenience only and do not in any manner serve as an endorsement of those Web sites. The materials at those Web sites are not part of the materials for this Printronix product and use of those Web sites is at your own risk.

Any performance data contained herein was determined in a controlled environment. Therefore, the results obtained in other operating environments may vary significantly. Some measurements may have been made on development-level systems and there is no guarantee that these measurements will be the same on generally available systems. Furthermore, some measurement may have been estimated through extrapolation. Actual results may vary. Users of this document should verify the applicable data for their specific environment.

Information concerning non-Printronix products was obtained from the suppliers of those products, their published announcements or other publicly available sources. Printronix has not tested those products and cannot confirm the accuracy of performance, compatibility or any other claims related to non-Printronix products. Questions on the capabilities of non-Printronix products should be addressed to the suppliers of those products.

Printronix encourages owners of information technology (IT) equipment to responsibly recycle their equipment when it is no longer needed. Printronix offers a variety of programs and services to assist equipment owners in recycling their IT products. Information on these product recycling offerings can be found on Printronix's Internet site at <http://www.primtronix.com>.

Note!

Before using this information and the product it supports, read the information and Communication Statements on page 360.

If you are viewing this information softcopy, the photographs and color illustrations may not appear.

For online versions of this book, we authorize you to:

- Copy, modify, and print the documentation contained on the media, for use within your enterprise, provided you reproduce the copyright notice, all warning statements, and other required statements on each copy or partial copy.
- Transfer the original unaltered copy of the documentation when you transfer the related Printronix product (which may be either machines you own, or programs, if the program's license terms permit a transfer). You must, at the same time, destroy all other copies of the documentation.

You are responsible for payment of any taxes, including personal property taxes, resulting from this authorization.

Your failure to comply with the terms above terminates this authorization. Upon termination, you must destroy your machine readable documentation.

Energy Star



The Environmental Protection Agency ENERGY STAR® Computers program is a partnership effort with manufacturers of data processing equipment to promote the introduction of energy-efficient personal computers, monitors, printers, fax machines, and copiers to help reduce air pollution and global warming caused by electricity generation.

Printronix participates in this program by introducing printers that reduce power consumption when they are not being used. As an ENERGY STAR® Partner, Printronix has determined that this product meets the ENERGY STAR® guidelines for energy efficiency.

NOTE: The ENERGY STAR® emblem does not represent EPA endorsement of any product or service.

Product Recycling and Disposal

This unit may have lead-containing materials – such as circuit boards and connectors – that require special handling. Before this unit is disposed of, these materials must be removed and recycled or discarded according to applicable regulations. This book contains specific information on batteries and refrigerant where applicable.

This product may contain a sealed, lead-acid battery; lithium battery; nickel-metal-hydride battery; or nickel-cadium battery. Batteries of these types must be recycled or disposed of properly. Recycling facilities may not be available in your area.

In the United States, Printronix has established a collection process for reuse, recycling, or proper disposal of used batteries and battery packs from Printronix equipment. For information on proper disposal of the batteries in this product, please contact Printronix.

For information on disposal of batteries outside the United States, contact your local waste disposal facility.

Communication Statements

Federal Communications Commission (FCC) Statement

This equipment has been tested and found to comply with the limits for a Class A digital device, pursuant to Part 15 of the FCC Rules. These limits are designed to provide reasonable protection against harmful interference when the equipment is operated in a commercial environment. This equipment generates, uses, and can radiate radio frequency energy and, if not installed and used in accordance with the instructions, may cause harmful interference to radio communications. Operation of this equipment in a residential area is likely to cause harmful interference in which case the user will be required to correct the interference at his own expense.

Properly shielded and grounded cables and connectors must be used in order to meet FCC emission limits. Printronix is not responsible for any radio or television interference caused by using other than recommended cables and connectors or by unauthorized changes or modifications to this equipment. Unauthorized changes or modifications could void the user's authority to operate the equipment.

This device complies with Part 15 of the FCC Rules. Operation is subject to the following two conditions: (1) this device may not cause harmful interference, and (2) this device must accept any interference received, including interference that may cause undesired operation.

European Union (EU) Conformity Statement



Hereby, Printronix declares that this product is in compliance with the essential requirements and other relevant provisions of Directive 1999/5/EC.

Printronix cannot accept responsibility for any failure to satisfy the protection requirements resulting from a non-recommended modification of the product, including the fitting of non-Printronix option cards.

This product has been tested and found to comply with the limits for Class A Information Technology Equipment according to European standard EN 55022. The limits for Class A equipment were derived for commercial and industrial environments to provide reasonable protection against interference with licensed communication devices.

WARNING

This is a Class A product. In a domestic environment this product may cause radio interference in which case the user may be required to take adequate measures.

Properly shielded and grounded cables and connectors must be used in order to reduce the potential for causing interference to radio and TV communications and to other electrical or electronic equipment. Printronix cannot accept responsibility for any interference caused by using other than recommended cables and connectors.

Industry Canada Compliance Statement

This Class A digital apparatus complies with Canadian ICES-003.

Cet appareil numérique de la classe A conform à la norme NMB-003 du Canada.

Appendix C Communication Statements

Statement of CISPR 22 Edition 2 Compliance

Attention: This is a Class A Product. In a domestic environment this product may cause radio interference in which case the user may be required to take adequate measures.

Japanese VCCI Class A

この装置は、情報処理装置等電波障害自主規制協議会（VCCI）の基準に基づくクラスA情報技術装置です。この装置を家庭環境で使用すると電波妨害を引き起こすことがあります。この場合には使用者が適切な対策を講ずるよう要求されることがあります。

German Conformity Statement

Handbuchttexte: FCC class A entspricht: EMVG Klasse A

Text Für alle in Deutschland vertriebenen EN 55022 Klasse A Geräte:

Zulassungsbescheinigung laut dem Deutschen Gesetz über die elektromagnetische Verträglichkeit von Geräten (EMVG) vom 18. September 1998 (bzw. der EMC EG Richtlinie 89/336):

Dieses Gerät ist berechtigt in Übereinstimmung mit dem Deutschen EMVG das EG-Konformitätszeichen - CE - zu führen.

Verantwortlich für die Konformitätserklärung nach Paragraph 5 des EMVG ist die: Printronix Deutschland GmbH, 70548 Stuttgart.

Informationen in Hinsicht EMVG Paragraph 4 Abs. (1) 4:

Das Gerät erfüllt die Schutzanforderungen nach EN 55024 und EN 55022 Klasse A.

EN 55022 Klasse A Geräte müssen mit folgendem Warnhinweis versehen werden: "Warnung: dies ist eine Einrichtung der Klasse A. Diese Einrichtung kann im Wohnbereich Funkstörungen verursachen; in diesem Fall kann vom Betreiber verlangt werden, angemessene Maßnahmen durchzuführen und dafür aufzukommen."

EN 55024 Hinweis:

Wird dieses Gerät in einer industriellen Umgebung betrieben (wie in EN 55024 festgelegt), dann kann es dabei eventuell gestört werden. In solch einem Fall ist der Abstand bzw. die Abschirmung zu der industriellen Störquelle zu übergrößen.

Anmerkung:

Um die Einhaltung des EMVG sicherzustellen sind die Geräte, wie in den Printronix Handbüchern angegeben, zu installieren und zu betreiben.

China

Declaration:

This is a Class A product. In a domestic environment this product may cause radio interference in which case the user may need to perform practical actions.

声 明

**此为 A 级产品, 在生活环境中,
该产品可能会造成无线电干扰,
在这种情况下, 可能需要用户对其
干扰采取切实可行的措施。**

Appendix C Communication Statements

Taiwan

Warning:

This is a Class A product. In a domestic environment this product may cause radio interference in which case the user will be required to take adequate measures.

警告使用者：
這是甲類的資訊產品，在居住的環境中使用時，可能會造成射頻干擾，在這種情況下，使用者會被要求採取某些適當的對策。

Korea

A급 기기(업무용)

이 기기는 업무용으로 전자파적합등록을 받은 기기이오니 판매자 또는 이용자는 이점을 주의하시기 바라며, 만약 구입하였을 때에는 구입한 곳에서 가정용으로 교환하시기 바랍니다.

CAUTION:

This product is equipped with a 3-wire power cord and plug for the user's safety. Use this power cord in conjunction with a properly grounded electrical outlet to avoid electrical shock.

Lithium Battery Warning

The controller board contains a lithium battery sealed inside the real-time clock chip. Do not disassemble the chip to replace the battery. Do not dispose of the chip by incineration. Failure to comply may cause the battery to explode. Contact your local waste agency for the correct disposal procedure.

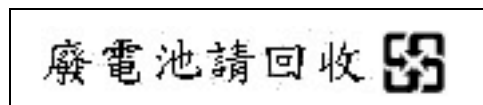

Software License Agreement

Your printer contains, among other software, Printronix operating software including, but not limited to the Embedded Configurable Operating System (the “eCos Software”) as embedded software. The terms of this Agreement apply only to the eCos Software, and all other embedded software supplied with the printer. You accept the terms of this Agreement by your initial use of your printer.

1. Object Code License

Printronix grants you a nonexclusive license to use the Printronix Software, the eCos Software and all other embedded software (collectively, the “Embedded Software” or the “Software”) only in conjunction with the printer. As the rightful possessor of the printer, you may make a reasonable number of copies of the Software as necessary for backup, configuration, and restoration of the printer. You must reproduce the copyright notice and any other legend of ownership on each copy of the Software you make.

You may transfer possession of the Software and its media to another party only with the transfer of the printer on which the Software is used. If you do so, you must give the other party a copy of these terms and provide all user documentation to that party. When you do so, you must destroy any copies of Software not resident in the printer.

Your license for the Software terminates when you no longer rightfully possess the printer. No other rights under this license are granted.

2. Source Code

A source code version of eCos Software is available under the terms of the Red Hat eCos Public License v1.1 at www.primtronix.com. Printronix grants no rights whatsoever in the source code for the Printronix Software.

3. No Warranty

THE EMBEDDED SOFTWARE IS PROVIDED UNDER THIS LICENSE ON AN "AS IS" BASIS, WITHOUT WARRANTY OF ANY KIND, EITHER EXPRESSED OR IMPLIED, INCLUDING, WITHOUT LIMITATION, WARRANTIES THAT THE EMBEDDED SOFTWARE IS FREE OF DEFECTS, MERCHANTABILITY, FIT FOR A PARTICULAR PURPOSE OR NON-INFRINGEMENT. THE ENTIRE RISK AS TO THE QUALITY AND PERFORMANCE OF THE EMBEDDED SOFTWARE IS WITH YOU. SHOULD ANY OF THE EMBEDDED SOFTWARE PROVE DEFECTIVE IN ANY RESPECT, YOU (NOT RED HAT, PRINTRONIX, ANY OTHER CONTRIBUTOR OR ANY DISTRIBUTOR) ASSUME THE COST OF ANY NECESSARY SERVICING, REPAIR OR CORRECTION. THIS DISCLAIMER OF WARRANTY CONSTITUTES AN ESSENTIAL PART OF THIS LICENSE. NO USE OF ANY OF THE EMBEDDED SOFTWARE IS AUTHORIZED HEREUNDER EXCEPT UNDER THIS DISCLAIMER.

4. Conflicting Terms

You agree that this Agreement provides you no more rights with regards to warranty, support, indemnity or liability terms with respect to Red Hat, Inc., Printronix, Inc. or any contributor to the Embedded Software than that provided by the Red Hat eCos Public License v.1.1 or any express warranty that may be made by Printronix, Inc.

5. Limitation of Liability

UNDER NO CIRCUMSTANCES AND UNDER NO LEGAL THEORY, WHETHER TORT (INCLUDING NEGLIGENCE), CONTRACT, OR OTHERWISE, SHALL RED HAT, PRINTRONIX, ANY OTHER CONTRIBUTOR, OR ANY DISTRIBUTOR OF THE EMBEDDED SOFTWARE, OR ANY PART THEREOF, OR ANY SUPPLIER OF ANY OF SUCH PARTIES, BE LIABLE TO YOU OR ANY OTHER PERSON FOR ANY INDIRECT, SPECIAL, INCIDENTAL, OR CONSEQUENTIAL DAMAGES OF ANY CHARACTER INCLUDING, WITHOUT LIMITATION, DAMAGES FOR LOSS OF GOODWILL, WORK STOPPAGE, COMPUTER FAILURE OR MALFUNCTION, OR ANY AND ALL OTHER COMMERCIAL DAMAGES OR LOSSES, EVEN IF SUCH PARTY SHALL HAVE BEEN INFORMED OF THE POSSIBILITY OF SUCH DAMAGES. THIS LIMITATION OF LIABILITY SHALL NOT APPLY TO LIABILITY FOR DEATH OR PERSONAL INJURY RESULTING FROM SUCH PARTY'S NEGLIGENCE TO THE EXTENT APPLICABLE LAW PROHIBITS SUCH LIMITATION. SOME JURISDICTIONS DO NOT ALLOW THE EXCLUSION OR LIMITATION OF INCIDENTAL OR CONSEQUENTIAL DAMAGES, SO THAT EXCLUSION AND LIMITATION MAY NOT APPLY TO YOU.

6. U.S. Government Users

The Embedded Software is a "commercial item," as that term is defined in 48 C.F.R. 2.101 (Oct. 1995), consisting of "commercial computer software" and "commercial computer software documentation," as such terms are used in 48 C.F.R. 12.212 (Sept. 1995). Consistent with 48 C.F.R. 12.212 and 48 C.F.R. 227.7202-1 through 227.7202-4 (June 1995), all U.S. Government End Users acquire Covered Code with only those rights set forth herein.

7. Miscellaneous

This Agreement represents the complete agreement concerning subject matter hereof. If any provision of this Agreement is held to be unenforceable, such provision shall be reformed only to the extent necessary to make it enforceable. This Agreement shall be governed by California law provisions (except to the extent applicable law, if any, provides otherwise), excluding its conflict-of-law provisions.

8. Red Hat Statement with regards to eCos Software

Part of the software embedded in this product is eCos - Embedded Configurable Operating System, a trademark of Red Hat. Portions created by Red Hat are Copyright (C) 1998, 1999, 2000 Red Hat, Inc. (<http://www.redhat.com>) All Rights Reserved.

THE SOFTWARE IN THIS PRODUCT WAS IN PART PROVIDED BY RED HAT AND ANY EXPRESS OR IMPLIED WARRANTIES, INCLUDING, BUT NOT LIMITED TO, THE IMPLIED WARRANTIES OF MERCHANTABILITY AND FITNESS FOR A PARTICULAR PURPOSE ARE DISCLAIMED. IN NO EVENT SHALL THE AUTHOR BE LIABLE FOR ANY DIRECT, INDIRECT, INCIDENTAL, SPECIAL, EXEMPLARY, OR CONSEQUENTIAL DAMAGES (INCLUDING, BUT NOT LIMITED TO, PROCUREMENT OF SUBSTITUTE GOODS OR SERVICES; LOSS OF USE, DATA, OR PROFITS; OR BUSINESS INTERRUPTION) HOWEVER CAUSED AND ON ANY THEORY OF LIABILITY, WHETHER IN CONTRACT, STRICT LIABILITY, OR TORT (INCLUDING NEGLIGENCE OR OTHERWISE) ARISING IN ANY WAY OUT OF THE USE OF THIS SOFTWARE, EVEN IF ADVISED OF THE POSSIBILITY OF SUCH DAMAGE.

Appendix C Software License Agreement



Index

Numerics

- 06 HOST REQUEST message, 317
- 08 HOLD PRINT TIMEOUT message, 317
- 15 COMM CHECK message, 317
- 15V PWR FAIL * message, 317
- 20 CPI Condensed
 - Epson FX Emulation, 243
 - Proprinter XL Emulation, 238
- 22 INVALID ADDR message, 317
- 23.5V PWR FAIL * message, 317
- 31 PAPER OUT TIMEOUT message, 317
- 32 PAPER JAM TIMEOUT message, 318
- 3270 Params, 187
- 3270 Params menu
 - Active Char Set, 189
 - Change Case, 191
 - Compatibility Op, 192
 - Early Print Cmpl, 189
 - Format Control, 195
 - Host Override, 195
 - Intervention Req, 191
 - Max. Print Width, 195
 - Prt Partial Line, 189
 - PTX Transparent, 190
 - Set Text Orientn, 191
 - Translation Tbl, 189
- 33 PLATEN OPEN TIMOUT message, 318
- 34 RIBBON STALL TIMOUT message, 318
- 48V PWR FAIL * message, 318
- 5225 World Trade, 182
- 5250 Params, 196
- 5250 Params menu
 - Active Char Set, 198
 - Format Control, 201
 - Graphic Chek Cod, 200
 - Graphic Chek Err, 199
 - Host Override, 201
 - Max. Print Width, 201
 - Prt Partial Line, 198
 - PTX Transparent, 198
 - Set Text Orientn, 200
 - Translation Tbl, 197
- 8.5V PWR FAIL * message, 317

A

- A TO D OVERUN * message, 318
- Absorb After ^PN, 160
- Absorb After ^PY, 156
- Accented Char, PRINTER CONTROL, 280
- ACCESS NULL PTR * message, 318
- Acknowledge, Centronics Parallel Interface Signals, 297
- Acoustic noise level, 349
- ACTIVATE LOST message, 319
- Active Char Set, 171, 181
 - 3270 Params menu, 189
 - 5250 Params menu, 198
- ACTIVE IGP EMUL menu, 125
- Active IGP Emulation, 77

Index

- Adapter Address, 75
- ADAPTER ADDRESS menu, 109
 - DHCP, 110
 - Gateway address, 109
 - IP address, 109
 - MAC address, 109
 - Subnet mask, 109
- ADAPTER PARAMS menu
 - ASCII data port, 112
 - Ethernet speed, 112
 - IPDS Data Port, 112
 - Job Control, 113
 - Keep alive timer, 112
 - Nest Serv Type, 111
 - NetBIOS protocol, 111
 - Novell frame, 111
 - Novell protocol, 111
- ADVANCED USER menu, 281
 - Alarm, 286
 - Auto Elevator, 284
 - Auto Locking, 284
 - Cancel Key, 287
 - Downloaded Fonts, 283
 - File System, 285
 - PMD (Paper Motion Detection)
 - Fault, 283
 - Power Saver Time, 287
 - Power Stacker, 284
 - Pwr Save Control, 287
 - Set Lock Key, 288
 - Set Sharing, 285
 - Shuttle Timeout, 286
 - Slow Paper Slew, 286
- AI 00 Spaces, 138, 158
- Alarm, ADVANCED USER menu, 286
- Alt. Char Set, Proprinter XL Emulation, 238
- Alt. Set 80-9F, 174, 223
 - Epson FX Emulation, 243
 - PTX Transparent, 183
 - Serial Matrix Emulation, 234
- ANSI Emulation menu, 248
 - Auto LF, 253
 - Barcode Darkmode, 256
 - BC Check Digit, 255
 - Character Set, 254
 - CPI/LPI Select, 250
 - Define CR Code, 253
 - Define LF Code, 253
 - ESC c Sequence, 254
 - ETX/ACK, 256
 - Font Attributes, 250
 - Page Format, 251
 - Pos. on BC/OvrSz, 255
 - Printer Select, 254
 - Private Mode, 255
 - PUM Default, 256
 - Received CR, 255
 - Received DEL, 255
 - Reset Cmd CFG Ld, 254
 - Truncate PI Slew, 256
- Append Rotated, 155
- ASCII Character Set, 353

ASCII data port, Adapter Params menu, 112
ASCII data port, Ethernet Parameters menu, 116
ASCII data port, WLAN Parameters menu, 120
Auth Method, WLAN LEAP menu, 123
Auto Elevator, ADVANCED USER menu, 284
Auto FF at ^PN, 160
Auto LF, 222
 ANSI Emulation menu, 253
 Epson FX Emulation, 242
 Proprinter XL Emulation, 237
 P-Series XQ Emulation, 229
 Serial Matrix Emulation, 233
Auto Locking, ADVANCED USER menu, 284
Auto Save Configuration, 60
Auto Skip At End, 177, 194
Auto Switching submenu, 86
 Auto Switching submenu, 87
 Port Type, 87
 Report Status, 88
 Timeout, 88
 Trickle Time, 87
Auto Trickle
 Centronics (Parallel) submenu, 93
 Dataproducts (Standard & Long Lines) submenu, 96
 IEEE 1284 Parallel (Bidirectional) Submenu, 89

Auto Uppercase, 135
Autowrap, 133
Autowrap, LG Emulation, 272

B

B10 ERROR NO DRAM DETECTED* message, 319
B11 ERROR RAM TEST FAILED* message, 319
B12 ERROR PROGRAM MISSING* message, 319
B13 ERROR NOT COMPATIBLE* message, 319
B19 ERROR DC RETURNED* message, 320
B20 STATUS 00% DOWNLOAD MODE message, 320
B21 STATUS PRINTER RESET message, 320
B22 ERROR DECOMPRESS SIZE* message, 320
B23 ERROR DECOMPRESS CKSUM* message, 321
B30 STATUS INITIALIZING, 321
B35 WAITING FOR EC STATUS, 321
B40 ERROR PROM CKSUM BAD* message, 321
B41 ERROR DIM MEMORY NOT SDRAM* message, 321
B42 ERROR SDRAM ROWS NOT ALLOWED* message, 321
B43 ERROR SDRAM TOO MANY BANKS* message, 322

Index

- B44 ERROR SDRAM NOT 64 BITS WIDE* message, 322
 - B45 ERROR SDRAM IS WRONG VOLTAGE* message, 322
 - B46 ERROR SDRAM HAS MIXED SIZES* message, 322
 - B47 ERROR SDRAM LARGER THAN 256M* message, 322
 - B49 ERROR SDRAM # LOGICAL BANKS* message, 323
 - B50 ERROR SDRAM LOGIC COMB BANKS* message, 323
 - B50 XX% CLEAR FLASH, 323
 - B51 ERROR 50A LINE STUCK LOW, 323
 - B51 XX% PROGRAMMING..., 323
 - B55 STATUS SEND PROGRAM TO EC, 323
 - Bar Code Quality, PRINTER CONTROL, 279
 - Bar Code Verification, 314
 - BARCODE DAMAGED message, 324
 - Barcode Darkmode, ANSI Emulation menu, 256
 - Barcode Errors, 161
 - BARCODE MISSING message, 324
 - Barcode Options, 137
 - AI 00 Spaces, 138
 - I 2/5 Selection, 138
 - Optimized Ratio, 137
 - Select SO Char, 138
 - UPC Descenders, 137
 - User-Def Ratio, 139
 - Barcode Quality, IPDS Emulation, 259
 - Barcode Size, IPDS Emulation, 260
 - Barcode Speed, IPDS Emulation, 260
 - Baud Rate, Serial submenu, 102
 - BC Check Digit, ANSI Emulation menu, 255
 - Buffer Clear, Dataproducts Parallel Interface Signals, 295
 - BUFFER OVERRUN message, 324
 - Buffer Print, 179, 186, 203
 - SPC Twx Params, 208
 - Buffer Reprint, 172, 204
 - Buffer Size in K
 - Centronics (Parallel) submenu, 93
 - Dataproducts (Standard & Long Lines) submenu, 96
 - Ethernet submenu, 106, 107
 - IEEE 1284 Parallel (Bidirectional) Submenu, 89
 - Serial submenu, 104
 - Busy On Strobe, Centronics (Parallel) submenu, 92
 - Busy, Centronics Parallel Interface Signals, 297
 - Byte Mode, IEEE 1284 Parallel Interface, 298
- C**
- Cable Verify, Dataproducts Parallel Interface Signals, 295
 - Cancel a print job, 52
 - Cancel IGP/DCU, 173, 182
 - CANCEL key, 30

- Cancel Key, ADVANCED USER menu, 287
- Centronics (Parallel) submenu, 91
 - Auto Trickle, 93
 - Buffer Size in K, 93
 - Busy On Strobe, 92
 - Data Bit 8, 91
 - Data Polarity, 92
 - Latch Data On, 92
 - PI Ignored, 92
 - Prime Signal, 93
 - Resp. Polarity, 92
 - TOF Action, 93
 - Trickle Time, 93
- Centronics Parallel Interface, 296
- Centronics Parallel Interface Signals, 297
 - Acknowledge, 297
 - Busy, 297
 - Data Lines 1 through 8, 297
 - Data Strobe, 297
 - Fault, 297
 - Online, 297
 - Paper Empty (PE), 297
 - Paper Instruction (PI), 297
 - Prime, 297
- Change Case, 174
- Change Case, 3270 Params menu, 191
- Changing parameter settings, 54
- Changing parameters, example, 57
- Changing Ribbons, 49
- Char Set Select, 171, 181
- Character Set, 224
- ANSI Emulation menu, 254
- ASCII, 353
- Epson FX Emulation, 243
- Proprinter XL Emulation, 237
- Serial Matrix Emulation, 234
- Characteristics, environmental, 348
- Cleaning
 - exterior, 311
 - interior, 312
- Cleaning requirements, 311
- CLEAR key, 29
- CLEAR PAPER JAM message, 324
- Clear to Send (CTS), RS-232, 306
- CLEARING PROGRAM FROM FLASH message, 325
- Clock Skew, WLAN Kerberos menu, 122
- CLOSE PLATEN message, 325
- Coax Emulation menu, 169
 - Active Char Set, 171
 - Buffer Print, 179
 - Buffer Reprint, 172
 - Cancel IGP/DCU, 173
 - Change Case, 174
 - Char Set Select, 171
 - Compatibility Op, 175
 - Early Print Cmpl, 172
 - Format Control, 178
 - Host Override, 178
 - Image Buf Size, 175
 - Intervention Req, 175
 - Max. Print Width, 179
 - PA1, 171

Index

- PA2, 172
- Prt Partial Line, 171
- PTX Transparent, 173
- SCS Buffer Cntrl, 173
- Set Text Orientn, 174
- Translate Table, 178
- Translation Tbl, 171
- Coax/Twinax (CTHI) Emulation menu, 167
 - Simple Prot Conv, 168
 - Standard, 167
- Code Page Subset, IPDS Emulation, 262
- COIL HOT message, 325
- Column 132 Wrap, 203
- Compatbl. Mode, 141
- Compatibility Mode, IEEE 1284 Parallel Interface, 298
- Compatibility Op, 175
 - Auto Skip At End, 177, 194
 - CR at MPP+1, 175, 192
 - CR, EM, and NL (3287 only), 177, 194
 - FF After Job, 177, 194
 - FF Validity, 176, 193
 - Last Char = FF, 176, 193
 - NL At MPP+1, 175, 192
 - Null Suppression, 176, 193
 - Position Aft FF (4234 only), 176, 192
- Compatibility Op, 3270 Params menu, 192
- Compliance, Energy Star, 349
- Component locations, printer, 26
- Compressed CPI, 140
- Compressed Print, P-Series XQ Emulation, 230
- Config Print, PCL-II Emulation, 268
- CONFIG. CONTROL menu, 82
 - Delete Config., 83
 - Load Config., 82
 - Name Configs, 84
 - Power-Up Config., 83
 - Print Config., 83
 - Protect Configs., 83
 - Reset Cfg Names, 84
 - Save Config., 83
- Configuration, Auto Save, 60
- Configurations
 - custom, 55
 - default, 55
 - overview, 53
 - saving, 61
- Control Code 06, 221
 - P-Series XQ Emulation, 228
 - Serial Matrix Emulation, 232
- Control Control Code 08, 221
- Control panel, 28
- Control panel keys
 - CANCEL, 30
 - CLEAR, 29
 - ENTER, 31
 - JOB SELECT, 31
 - ON LINE, 29
 - PAPER ADVANCE, 29
 - PREV + NEXT, 32
 - PREV or NEXT, 32
 - PRT CONFIG, 30
 - SET TOF, 30

- UP + DOWN, 31
- UP or DOWN, 31
- VIEW/EJECT key, 29
- Conventions, manual, 18
- CPI/LPI Select, 213
 - ANSI Emulation menu, 250
- CR at MPP+1, 175, 192
- CR Edit, 134
- CR, EM, and NL (3287 only), 177, 194
- CR, LG Emulation, 273
- CTL VOLT FAIL * message, 325
- Custom configurations, 55
- Customer Support Center, 20
- D**
- Darker print, Integrated Print Management System, 48
- Data Bit 8, 163
 - Centronics (Parallel) submenu, 91
 - Dataproducts (Standard & Long Lines) submenu, 95
- Data Carrier Detect (DCD), RS-232, 306
- Data Lines 1 through 8
 - Centronics Parallel Interface Signals, 297
 - Dataproducts Parallel Interface Signals, 295
- Data Polarity
 - Centronics (Parallel) submenu, 92
 - Dataproducts (Standard & Long Lines) submenu, 95
- Data Protocol, Serial submenu, 99
- Data Set Ready (DSR), RS-232, 306
- Data Strobe
 - Centronics Parallel Interface Signals, 297
 - Dataproducts Parallel Interface Signals, 295
- Data Term Ready, Serial submenu, 103
- Data Terminal Ready (DTR), RS-232, 306
- Dataproducts (Standard & Long Lines) submenu
 - Auto Trickle, 96
 - Buffer Size in K, 96
 - Data Bit 8, 95
 - Data Polarity, 95
 - Latch Data On, 95
 - PI Ignored, 95
 - Prime Signal, 96
 - Resp. Polarity, 95
 - TOF Action, 96
 - Trickle Time, 96
- Dataproducts (Standard) submenu, 94
- Dataproducts Parallel Interface, 294
- Dataproducts Parallel Interface Signals, 295
 - Buffer Clear, 295
 - Cable Verify, 295
 - Data Lines 1 through 8, 295
 - Data Strobe, 295
 - Demand/Data Request, 295
 - Online, 295
 - Paper Instruction (PI), 295
 - Parity Error, 295
 - Ready, 295

Index

- Default Code Page, IPDS Emulation, 261
 - Default configurations, 55
 - Default Font, IPDS Emulation, 262
 - Define CR Code, 133, 222
 - ANSI Emulation menu, 253
 - Epson FX Emulation, 241
 - Proprinter XL Emulation, 236
 - P-Series XQ Emulation, 229
 - Serial Matrix Emulation, 233
 - Define LF Code, 133, 222
 - ANSI Emulation menu, 253
 - Epson FX Emulation, 242
 - Proprinter XL Emulation, 237
 - P-Series XQ Emulation, 229
 - Serial Matrix Emulation, 233
 - Delete Config., 83
 - Demand/Data Request, Dataproducts Parallel Interface Signals, 295
 - Device Address, 182, 207
 - Device ID, 75, 182
 - DHCP
 - Adapter Address menu, 110
 - Ethernet Address menu, 114
 - WLAN Address menu, 118
 - DIAGNOSTIC PASSED message, 325
 - DIAGNOSTICS menu, 289
 - DRAM Avail., 292
 - Flash Avail., 292
 - Paper Out Dots, 291
 - Print Statistics, 292
 - Printer Tests, 290
 - System Memory, 291
 - Test Width, 289
 - Dimensions, printer, 23, 348
 - Display Functions, PCL-II Emulation, 266
 - Display Language, PRINTER CONTROL, 280
 - DO NOT POWER OFF message, 325
 - Documentation list, 19
 - Downloaded Fonts, ADVANCED USER menu, 283
 - DRAM Avail., DIAGNOSTICS, 292
 - DRVR CIR BAD * message, 325
- ### E
- E NET TEST UNAVAILABLE message, 326
 - Early Print Cmpl, 172
 - 3270 Params menu, 189
 - Early Print Comp (Complete), IPDS Emulation, 260
 - Eject Function, PRINTER CONTROL menu, 277
 - Electrical Characteristics, 350
 - Elong/Alt. Font, P-Series XQ Emulation, 230
 - EMULATION Menu, 166
 - Emulation, IGP/PGL, 126
 - Energy Star compliance, 349
 - E-Net Adapter submenu, 106
 - ENTER key, 31
 - Environmental characteristics, 348

- Epson FX Character Set menu, 244, 245
 - LG, 247
 - PCL-II, 246
- Epson FX Emulation, 241
 - 20 CPI Condensed, 243
 - Alt. Set 80-9F, 243
 - Auto LF, 242
 - Character Set, 243
 - Define CR Code, 241
 - Define LF Code, 242
 - Printer Select, 242
- ERROR DC PROGRAM NOT VALID message, 326
- ERROR DRAM AT ADDRESS XXXXXXXX message, 326
- ERROR EC PROGRAM NOT VALID message, 326
- ERROR EC STOPPED AT XXXX message, 326
- ERROR FLASH DID NOT PROGRAM message, 327
- ERROR FLASH NOT DETECTED message, 327
- Error Handling, 161
 - Barcode Errors, 161
 - Error Markers, 161
 - Error Msgs, 161
 - Offpage Errors, 161
- ERROR LOCKED
- SN=nnnnnnnnnnnnnnnnnnnnnnnnnnnn message, 327
- Error Markers, 161
- Error Msgs, 161
- ERROR NO DRAM DETECTED message, 327
- ERROR NVRAM FAILURE message, 327
- ERROR OCCURRED FLUSHING QUEUES* message, 328
- ERROR PROGRAM NEEDS MORE DRAM message, 328
- ERROR PROGRAM NEEDS MORE FLASH message, 328
- ERROR PROGRAM NOT COMPATIBLE message, 328
- ERROR PROGRAM NOT VALID message, 328
- Error Report, 144
- ERROR SECURITY KEY NOT DETECTED message, 328
- ERROR SHORT AT ADDRESS XXXX message, 328
- ERROR WRITING TO FLASH message, 329
- ERROR WRONG CHECKSUM message, 329
- ERROR WRONG OEM OR PRINTER TYPE message, 329
- ESC c Sequence, ANSI Emulation menu, 254
- ESC d command, Serial Matrix Emulation, 234
- ETHERNET ADAPTER BEING INITIALIZED message, 329
- Ethernet Address, 76

Index

ETHERNET ADDRESS menu, 113

DHCP, 114

Gateway address, 114

IP address, 113

MAC address, 114

Subnet mask, 114

ETHERNET DETECTED message, 329

ETHERNET PARAMETERS menu

ASCII data port, 116

Ethernet speed, 116

IPDS Data Port, 116

Job Control, 117

Keep alive timer, 116

NetBIOS protocol, 115

ETHERNET PARAMS menu, 115

Ethernet speed, Adapter Params
menu, 112

Ethernet speed, Ethernet Parameters
menu, 116

Ethernet submenu, 107

Buffer Size in K, 106, 107

ETX/ACK, ANSI Emulation menu, 256

EVFU, SPC Type, 208

EXCESS RBN WEAR message, 329

EXHAUST FAN FLT message, 330

Expanded Font, 141, 157

Ext Execute Copy, 136

Exterior cleaning, 311

F

Face CPI Delay, PCL-II Emulation, 266

Fault messages, 316

06 HOST REQUEST, 317

08 HOLD PRINT TIMEOUT, 317

15 COMM CHECK, 317

15V PWR FAIL *, 317

22 INVALID ADDR, 317

23.5V PWR FAIL *, 317

31 PAPER OUT TIMEOUT, 317

32 PAPER JAM TIMEOUT, 318

33 PLATEN OPEN TIMEOUT, 318

34 RIBBON STALL TIMEOUT, 318

48V PWR FAIL *, 318

8.5V PWR FAIL *, 317

A TO D OVERUN *, 318

ACCESS NULL PTR *, 318

ACTIVATE LOST, 319

B10 ERROR NO DRAM

DETECTED*, 319

B11 ERROR RAM TEST FAILED*, 319

B12 ERROR PROGRAM

MISSING*, 319

B13 ERROR NOT

COMPATIBLE*, 319

B19 ERROR DC RETURNED*, 320

B20 STATUS 00% DOWNLOAD

MODE, 320

B21 STATUS PRINTER RESET, 320

B22 ERROR DECOMPRESS

SIZE*, 320

B23 ERROR DECOMPRESS
 CKSUM*, 321
B30 STATUS INITIALZING, 321
B35 STATUS WAITING FOR EC
 STATUS, 321
B40 ERROR SDRAMEE PROM
 CKSUM BAD*, 321
B41 ERROR DIM MEMORY NOT
 SDRAM*, 321
B42 ERROR SDRAM ROWS NOT
 ALLOWED*, 321
B43 ERROR SDRAM TOO MANY
 BANKS*, 322
B44 ERROR SDRAM NOT 64 BITS
 WIDE*, 322
B45 ERROR SDRAM IS WRONG
 VOLTAGE*, 322
B46 ERROR SDRAM HAS MIXED
 SIZES*, 322
B47 ERROR SDRAM LARGER THAN
 256M*, 322
B49 ERROR SDRAM # LOGICAL
 BANKS*, 323
B50 ERROR SDRAM LOGIC COMB
 BANKS*, 323
B50 XX% CLEAR FLASH, 323
B51 ERROR 50A LINE STUCK
 LOW, 323
B51 XX% PROGRAMMING..., 323
B55 STATUS SEND PROGRAM TO
 EC, 323
BARCODE DAMAGED, 324
BARCODE MISSING, 324
BUFFER OVERRUN, 324
CLEAR PAPER JAM, 324
CLEARING PROGRAM FROM
 FLASH, 325
CLOSE PLATEN, 325
COIL HOT, 325
CTL VOLT FAIL *, 325
DIAGNOSTIC PASSED, 325
DO NOT POWER OFF, 325
DRVR CIR BAD *, 325
E NET TEST UNAVAILABLE, 326
ERROR DC PROGRAM NOT
 VALID, 326
ERROR DRAM AT ADDRESS
 XXXXXXXX, 326
ERROR EC PROGRAM NOT
 VALID, 326
ERROR EC STOPPED AT STATE
 XXXX, 326
ERROR FLASH DID NOT
 PROGRAM, 327
ERROR FLASH NOT
 DETECTED, 327
ERROR LOCKED
 SN=nnnnnnnnnnnnnnnnnnnn
 n, 327
ERROR NO DRAM DETECTED, 327
ERROR NVRAM FAILURE, 327
ERROR OCCURRED FLUSHING
 QUEUES*, 328

Index

ERROR PROGRAM NEEDS MORE
 DRAM, 328

ERROR PROGRAM NEEDS MORE
 FLASH, 328

ERROR PROGRAM NOT
 COMPATIBLE, 328

ERROR PROGRAM NOT VALID, 328

ERROR SECURITY KEY NOT
 DETECTED, 328

ERROR SHORT AT ADDRESS
 XXXX, 328

ERROR WRITING TO FLASH, 329

ERROR WRONG CHECKSUM, 329

ERROR WRONG OEM OR PRINTER
 TYPE, 329

ETHERNET ADAPTER BEING
 INITIALIZED, 329

ETHERNET DETECTED, 329

EXCESS RBN WEAR, 329

EXHAUST FAN FLT, 330

FIRMWARE ERROR, 330

FM HEADER ERROR, 330

FRAMING ERROR, 330

FREEFORM OFF, 331

FREEFORM ON OFF HOLD KEY @
 PWRUP, 331

GRF CHECK ERROR PRESS
 STOP, 331

HAM. COIL OPEN *, 331

HAMMER COIL BAD, ###, 331

HB NOT INSTALLED *, 331

HMR BANK FAN FLT, 332

ILL EXT BUS ACC *, 332

ILLGL OPR ACCSS *, 332

INCOMPAT E-NET, 332

INTAKE FAN FAULT, 332

INTERRUPT UNUSED
 VECTOR 00, 333

INVALID ACTIVATE, 333

INVALID COMMAND, 333

LO DRV. SHORT *, 333

LOAD PAPER, 333

LOADING PROGRAM FROM
 PORT XX%, 333

LOADING PROGRAM INTO
 FLASH, 334

NEW SPX DETECTED, 334

NON VOLATILE MEMORY
 FAILED, 334

OLD RIBBON, 334

ON LINE, 334

ONLINE 28 CU NOT ENAB, 334

ONLINE 8344 FAILED, 334

ONLINE CU TIMED OUT, 335

PAP BAD TABLE *, 335

PAP BSY TOO LNG *, 335

PAP FIFO OVERFL *, 335

PAP FIFO UNDRFL *, 335

PAP ILLGL ST *, 335

PAP INCMPL ENER *, 335

PAP INVLD CMD *, 335

PAP INVLD PARM *, 335

PAP NOT SCHED *, 336

PAP NT AT SPEED *, 336

- PAP UNEXP INT *, 336
- PARAMETER ERROR, 336
- PARITY ERROR, 336
- PLAT INV CMD *, 336
- PLAT INV PARM *, 336
- PLAT INV STATE *, 336
- PLEASE WAIT...RESET IN
 - PROGRESS, 337
- POWER SAVER MODE, 337
- POWERSUPPLY HOT *, 337
- PRINTER HOT *, 337
- PRINTER UNDER REMOTE
 - CONTROL, 337
- PROTECTED INSTR *, 338
- PWRSUPP VOLT *, 338
- QUEUE OVERRUN*, 338
- RBN AT END POINT, 339
- RBN SENSOR ERROR, 338
- REMOVE USED SPX, 338
- RESTORING BOOT CODE, 338
- RIB INVLD CMD*, 338
- RIB INVLD STATE*, 339
- RIBBON DRIVE, 339
- RIBBON NOT RECOGNIZED, 339
- RIBBON STALL, 339
- RIBBON UNDER 2%, 339
- SCS COMMAND ERROR, 339
- SECURITY KEY NOT
 - DETECTED, 340
- SECURITY VIOLATION, 339
- SENDING PROGRAM TO EC
 - PROCESSOR, 340
- SHUTL INV CMD *, 340
- SHUTL INV PARM *, 340
- SHUTL OVR SPEED*, 340
- SHUTTLE JAM, 340
- SHUTTLE STALL, 341
- SOFTWARE ERROR* CYCLE
 - POWER, 341
- SPX FOUND, ERROR KEY NOT
 - DETECTED, 341
- SPX NOT NEEDED OPTIONS
 - ENABLED, 341
- SSTACKER JAM, 342
- STACK OVERFLOW*, 341
- STACK UNDERFLOW*, 341
- STACKER FAULT, 342
- STACKER FULL, 342
- TABLE MISMATCH DOWNLOAD
 - AGAIN, 342
- TCB CORRUPTED*, 342
- TCP PORT BUSY, 342
- UNDEF INTERRUPT*, 343
- UNDFNED OPCODE*, 343
- UNKNOWN RBN1, 343
- UNKNOWN RBN2, 343
- UP DRV. SHORT*, 343
- WAITING FOR ETHERNET
 - ADAPTER, 343
- Fault, Centronics Parallel Interface
 - Signals, 297
- Features, printer, 13
- FF After Job, 177, 194

Index

- FF Valid at TOF, Proprinter XL Emulation, 237
 - FF Validity, 176, 193
 - FF, LG Emulation, 274
 - File System, ADVANCED USER menu, 285
 - FIRMWARE ERROR message, 330
 - Flash Avail., DIAGNOSTICS, 292
 - FM HEADER ERROR message, 330
 - Font Attributes, 214
 - ANSI Emulation menu, 250
 - Font Set, 163
 - Font Size, IPDS Emulation, 259
 - Font, LG Emulation, 271
 - Form Length, 77, 79
 - Form Width, 77, 79
 - Format Control, 178, 186
 - 3270 Params menu, 195
 - 5250 Params menu, 201
 - Forms Handling, 135
 - FRAMING ERROR message, 330
 - Framing Errors, Serial submenu, 105
 - FREEFORM OFF message, 331
 - FREEFORM ON OFF HOLD KEY @ PWRUP message, 331
- G**
- Gateway address
 - Adapter Address menu, 109
 - Ethernet Address menu, 114
 - WLAN Address menu, 118
 - Graphic CharSize, IPDS Emulation, 261
 - Graphic Chek Cod, 184
 - Graphic Chek Cod, 5250 Params menu, 200
 - Graphic Chek Err, 184
 - Graphic Chek Err, 5250 Params menu, 199
 - Graphics Density, PCL-II Emulation, 266
 - Graphics enhancement, 17
 - Graphics Options, 155
 - Absorb After ^PN, 160
 - Absorb After ^PY, 156
 - AI 00 Spaces, 158
 - Append Rotated, 155
 - Auto FF at ^PN, 160
 - Expanded Font, 157
 - I25 Selection, 158
 - Ignore ^Lxx Cmd., 160
 - Ignore Dots, 155
 - Ignore Spaces, 157
 - IGP110 Compatbl., 160
 - LP+ Font, 157
 - Midline PY (includes ^PN), 157
 - MSI Check Digit, 158
 - Print Quality, 157
 - Rot. Char Size, 156
 - Slash 0, 155
 - True Vert 1/10, 156
 - Truncate Alpha, 155
 - UPC Descenders, 156
 - Width Limit, 159
 - Graphics Print, IPDS Emulation, 259
 - Graphics Quality, IPDS Emulation, 259
 - Graphics Scaling, IPDS Emulation, 261

GRF CHECK ERROR PRESS STOP
message, 331

H

HAM. COIL OPEN * message, 331
HAMMER COIL BAD, ### Message, 331
HB NOT INSTALLED * message, 331
Hex Dump Mode, MAINT/MISC menu, 282
Hex Dump, printing, 315
Hexdump Mode, IPDS Emulation, 262
HMR BANK FAN FLT Message, 332
Horiz Forms, 80
Horiz Forms, LG Emulation, 272
Host Command, 213
Host Form Length, 139
Host Interface, 75
HOST INTERFACE menu, 85
Host Override, 178, 185
 3270 Params menu, 195
 5250 Params menu, 201
Host PI, 164
HS Print (High Speed Print), P-Series XQ
Emulation, 230

I

I 2/5 Checksum, IPDS Emulation, 261
I 2/5 Selection, 138
I-2/5 Guard Bars, LG Emulation, 275
I25 Selection, 158
Idle Response, Serial submenu, 104

IEEE 1284 Parallel (Bidirectional)
Submenu, 88

 Auto Trickle, 89
 Buffer Size in K, 89
 Offline Process, 90
 Prime Signal, 89
 TOF Action, 89
 Trickle Time, 89

IEEE 1284 Parallel Interface, 298
 Byte Mode, 298
 Compatibility Mode, 298
 Nibble Mode, 298
 Signals, 299

Ignore ^Lxx Cmd., 160
Ignore CH#1, 162
Ignore CH#2, 162
Ignore Char, 140
Ignore Chars, 162
Ignore Dots, 155
Ignore Spaces, 157
Ignore/DB8 Setup, 162
 Data Bit 8, 163
 Ignore CH#1, 162
 Ignore CH#2, 162
 Ignore Chars, 162

IGP/PGL Emulation, 126
 configuring with the control panel, 128
IGP/PGL submenu, 129
 Auto Uppercase, 135
 Autowrap, 133
 Barcode Options, 137
 Compatbl. Mode, 141

Index

- Compressed CPI, 140
- CR Edit, 134
- Define CR (Carriage Return)
 - Code, 133
- Define LF (Line Feed) Code, 133
- Error Report, 144
- Expanded Font, 141
- Ext Execute Copy, 136
- Forms Handling, 135
- Host Form Length, 139
- Ignore Char, 140
- LG, 132
- PCL-II, 131
- PGL SFCC, 133
- PI Slew Range, 134
- Power On IGP/PGL, 136
- Power on S-Mode, 143
- Print Quality, 143
- Printer PI Line, 142
- Scalable Size, 142
- Select Font, 134
- Select LPI, 135
- Skip Cmd Prefix, 135
- Slash 0, 134
- True Form Slew, 142
- Trunc Dyn Data, 143
- Var Form Adjust, 139
- Var Form Type, 140
- IGP/PGL, Font Set menu, 145
- IGP/VGL Emulation, 146
 - configuring with the control panel, 147
- IGP/VGL Font Set Menu, 165
- IGP/VGL submenu, 148
 - Error Handling, 161
 - Font Set, 163
 - Graphics Options, 155
 - Ignore/DB8 Setup, 162
 - LG, 152
 - LPI, 154
 - PCL-II, 150
 - PI Control, 163
 - Prt to Emulate, 164
 - SFCC & Pwrup, 154
- IGP110 Compatbl., 160
- ILL EXT BUS ACC * message, 332
- ILLGL OPR ACCSS * message, 332
- Image Buf Size, 175, 202
- INCOMPAT E-NET message, 332
- Ink Saver Mode, PRINTER CONTROL, 289
- INTAKE FAN FAULT message, 332
- Integrated Print Management System, 15, 48
 - Darker Print, 48
 - Lighter Print, 48
- Interface Type, Serial submenu, 99
- Interfaces
 - printer, 293
 - specifications, 351
- Interior cleaning, 312
- INTERRUPT UNUSED VECTOR 00 message, 333
- Intervention Req, 175, 203
- Intervention Req, 3270 Params menu, 191

INVALID ACTIVATE message, 333

INVALID COMMAND message, 333

IP address

 Adapter Address menu, 109

 Ethernet Address menu, 113

 WLAN Address menu, 117

IPDS Data Port, Adapter Params menu, 112

IPDS Data Port, Ethernet Parameters menu, 116

IPDS Data Port, WLAN Parameters menu, 120

IPDS Emulation, 257

 Barcode Quality, 259

 Barcode Size, 260

 Barcode Speed, 260

 Code Page Subset, 262

 Default Code Page, 261

 Default Font, 262

 Early Print Comp (Complete), 260

 Font Size, 259

 Graphic CharSize, 261

 Graphics Quality, 259

 Graphics Scaling, 261

 Hexdump Mode, 262

 I 2/5 Checksum, 261

 Print IPDS Fonts, 262

 Print Quality, 259

 VPA Check, 262

J

Job Control, Adapter Params menu, 113

Job Control, Ethernet Parameters menu, 117

JOB SELECT key, 31

K

KDC Port Number, WLAN Kerberos menu, 122

Keep alive timer, Adapter Params menu, 112

Keep alive timer, Ethernet Parameters menu, 116

Keep alive timer, WLAN Parameters menu, 120

Kerberos Enable, WLAN Kerberos menu, 121

Kerberos Password, WLAN Kerberos menu, 122

L

Label specifications, 347

LAC Approx., 185

LAC Option, 184

Last Char = FF, 176, 193

Latch Data On

 Centronics (Parallel) submenu, 92

 Dataproducts (Standard & Long Lines) submenu, 95

Lead-in Chars, 173

 PTX Transparent, 183

LEAP Password, WLAN LEAP menu, 124

LEAP Username, WLAN LEAP menu, 124

Index

- LG Emulation
 - Autowrap, 272
 - CR, 273
 - FF, 274
 - Font, 271
 - Horiz Forms, 272
 - I-2/5 Guard Bars, 275
 - LP, 273
 - Plot Mode Opt, 275
 - Print Mode Opt, 274
 - Unsolicited Rpt, 274
 - Vert Forms, 271
 - Lighter print, Integrated Print Management System, 48
 - Line Terminator, PCL-II Emulation, 266
 - LinePrinter Plus Emulation submenu, 209
 - Barcode X-Offset, 218
 - CPI/LPI Select, 213
 - Font Attributes, 214
 - Host Command, 213
 - Page Format, 217
 - PCL-II, 212
 - Print Char. Set, 217
 - Printer Protocol, 213
 - Reset Cmd CFG Ld, 218
 - Set Substitution, 218
 - LO DRV. SHORT * message, 333
 - Load Config., 82
 - LOAD PAPER message, 333
 - LOADING PROGRAM FROM PORT XX% message, 333
 - LOADING PROGRAM INTO FLASH message, 334
 - Loading Used Ribbon, 16
 - Logical Buf Size, 202
 - LP+ Font, 157
 - LP, LG Emulation, 273
 - LPI, 154
 - LPI Adjust, PCL-II Emulation, 267
- ### M
- MAC address
 - Adapter Address menu, 109
 - Ethernet Address menu, 114
 - WLAN Address menu, 118
 - Main menu, 70
 - MAINT/MISC menu
 - Hex Dump Mode, 282
 - Power-Up State, 283
 - PTX Setup Option, 282
 - Maintenance, 17
 - Manual
 - conventions, 18
 - related documents, 19
 - special information, 18
 - warnings, 18
 - Margins, 78
 - Max Line Width, 80
 - Max Line Width, PCL-II Emulation, 265
 - Max PI 16, 164
 - Max. Print Width, 179, 186
 - 3270 Params menu, 195
 - 5250 Params menu, 201

Menu

- ACTIVE IGP EMUL, 125
- ADVANCED USER, 281
- CONFIG. CONTROL, 82
- DIAGNOSTICS, 289
- EMULATION, 166
- HOST INTERFACE, 85
- IGP/PGL Font Set, 145
- Main, 70
 - navigating, 56
- NETWORK SETUP, 108
- PRINTER CONTROL, 276

- Midline PY (includes ^PN), 157
- MSI Check Digit, 158

N

- Name Configs, 84
- Navigating the menus, 56
- Nest Serv Type, Adapter Params menu, 111
- NetBIOS protocol, Adapter Params menu, 111
- NetBIOS protocol, Ethernet Parameters menu, 115
- NetBIOS protocol, WLAN Parameters menu, 119
- NETWORK SETUP menu, 108
 - ADAPTER ADDRESS, 109
 - ETHERNET ADDRESS, 113
 - ETHERNET PARAMS, 115
 - WLAN ADDRESS, 117
 - WLAN PARAMS, 119
- NEW SPX DETECTED message, 334

- Nibble Mode, IEEE 1284 Parallel Interface, 298
- NL At MPP+1, 175, 192, 205
- noise level, acoustic, 349
- NON VOLATILE MEMORY FAILED message, 334
- Novell frame, Adapter Params menu, 111
- Novell protocol, Adapter Params menu, 111
- Novell Protocols, 110
- Null Suppression, 176, 193

O

- Offline Process
 - IEEE 1284 Parallel (Bidirectional) Submenu, 90
- Offpage Errors, 161
- OLD RIBBON message, 334
- ON LINE key, 29
- ON LINE message, 334
- One Char Enquiry, Serial submenu, 105
- Online
 - Centronics Parallel Interface Signals, 297
 - Dataproducts Parallel Interface Signals, 295
- ONLINE 28 CU NOT ENAB message, 334
- ONLINE 8344 FAILED message, 334
- ONLINE CU TIMED OUT message, 335
- Open Platen @ BOF (Bottom of Form) PRINTER CONTROL, 278
- Operating modes, 27

Index

- Operational procedures
 - cancel a print job, 52
 - reload paper, 34
 - unload paper, 45
 - Optimized Ratio, 137
 - Optimizing print quality, 68
 - Optimizing print speed, 69
 - Output Darkness, 15
 - Overstrike, 222
 - Serial Matrix Emulation, 233
 - Overview, printer models, 13
- P**
- PA1, 171, 204
 - PA2, 172, 204
 - Page Format, 217
 - ANSI Emulation menu, 251
 - Page L./Inches, PCL-II Emulation, 268
 - Page L./Lines, PCL-II Emulation, 267
 - Page Length Rep, 80
 - Page Length Rep, PCL-II Emulation, 265
 - PAP BAD TABLE * message, 335
 - PAP BSY TOO LNG * message, 335
 - PAP FIFO OVERFL * message, 335
 - PAP FIFO UNDRFL * message, 335
 - PAP ILLGL ST * message, 335
 - PAP INCMPL ENER * message, 335
 - PAP INVLD CMD * message, 335
 - PAP INVLD PARM * message, 335
 - PAP NOT SCHED * message, 336
 - PAP NT AT SPEED * message, 336
 - PAP UNEXP INT * message, 336
 - Paper
 - reload, 34
 - unload, 45
 - PAPER ADVANCE key, 29
 - Paper Empty (PE)
 - Centronics Parallel Interface
 - Signals, 297
 - Paper Instruction (PI)
 - Centronics Parallel Interface
 - Signals, 297
 - Dataproducts Parallel Interface
 - Signals, 295
 - Paper Out Dots, DIAGNOSTICS, 291
 - Paper specifications, 346
 - Parallel Interface
 - Centronics, 296
 - Dataproducts, 294
 - PARAMETER ERROR message, 336
 - Parameter settings
 - changing, 54
 - saving, 54
 - Parameters, changing, example, 57
 - Parity Error
 - Dataproducts Parallel Interface
 - Signals, 295
 - PARITY ERROR message, 336
 - Parity, Serial submenu, 102
 - PCL-II Emulation, 263
 - Config Print, 268
 - Display Functions, 266
 - Face CPI Delay, 266
 - Graphics Density, 266

Index

- Line Terminator, 266
- LPI Adjust, 267
- Max Line Width, 265
- Page L./Inches, 268
- Page L./Lines, 267
- Page Length Rep, 265
- Perforation Skip, 266
- Primary Char. Set, 265
- PTX Linefeed, 267
- Reset Cmd CFG Ld, 268
- Second Char. Set, 265
- Symbol Set Print, 268
- Perforation Skip, PCL-II Emulation, 266
- PGL SFCC, 77, 133
- PI Control, 163
 - Host PI, 164
 - Max PI 16, 164
 - Printer PI, 163
- PI Ignored
 - Centronics (Parallel) submenu, 92
 - Dataproducts (Standard & Long Lines) submenu, 95
- PI Slew Range, 134
- PLAT INV CMD * message, 336
- PLAT INV PARM * message, 336
- PLAT INV STATE * message, 336
- PLEASE WAIT...RESET IN PROGRESS message, 337
- Plot Mode Opt, LG Emulation, 275
- PMD (Paper Motion Detection) Fault, ADVANCED USER, 283
- Poll Character, Serial submenu, 104
- Poll Response, Serial submenu, 104
- Port Type, Auto Switching submenu, 87
- Pos. on BC/OvrSz, ANSI Emulation menu, 255
- Position Aft FF (4234 only), 176, 192
- Power Consumption, 350
- Power On IGP/PGL, 136
- Power requirements, 21
- POWER SAVER MODE message, 337
- Power Saver Time, ADVANCED USER, 287
- Power Stacker, ADVANCED USER menu, 284
- POWER SUPPLY HOT * message, 337
- Power Up ^ F, 154
- Power Up ^ X, 154
- Power Up ^PY, 154
- Powering on the printer, 27
- Power-on S-Mode, 143
- Power-Up Config, 81
- Power-Up Config., 83
- Power-Up State, MAINT/MISC menu, 283
- PREV + NEXT key, 32
- PREV or NEXT key, 32
- Primary Char. Set, PCL-II Emulation, 265
- Prime Signal
 - Centronics (Parallel) submenu, 93
 - Dataproducts (Standard & Long Lines) submenu, 96
 - IEEE 1284 Parallel (Bidirectional) Submenu, 89

Index

- Prime, Centronics Parallel Interface Signals, 297
- Print Char. Set, 217
- Print Config., 83
- Print IPDS Fonts, IPDS Emulation, 262
- Print job, cancel, 52
- Print Mode Opt, LG Emulation, 274
- Print Quality, 143, 157
 - optimizing, 68
- Print speed, optimizing, 69
- Print Statistics, DIAGNOSTICS, 292
- Printer
 - component locations, 26
 - control panel, 28
 - dimensions, 23, 348
 - exterior cleaning, 311
 - features, 13
 - interior cleaning, 312
 - maintenance, 17
 - models, 13
 - operating modes, 27
 - powering on, 27
 - site requirements, 22
 - weight, 348
- PRINTER CONTROL menu, 276
 - Accented Char, 280
 - Bar Code Quality, 279
 - Display Language, 280
 - Eject Function, 277
 - Ink Saver Mode, 289
 - Open Platen @ BOF (Bottom of Form), 278
 - Ribbon Action, 288
 - Ribbon End Point, 277
 - Tear Bar Dist. (Distance), 279
 - Unidirectional, 279
- PRINTER HOT * message, 337
- Printer interfaces, 293
- Printer PI, 163
- Printer PI Line, 142
- Printer Protocol, 77, 213
- Printer Select
 - ANSI Emulation menu, 254
 - Epson FX Emulation, 242
 - Serial Matrix Emulation, 234
- Printer Tests, DIAGNOSTICS, 290
- Printer Type, SPC Type, 207
- PRINTER UNDER REMOTE CONTROL message, 337
- Printing rates, 351
- Printing, Hex Dump, 315
- PrintNet Enterprise, consumable monitoring, 17
- Private Mode, ANSI Emulation menu, 255
- Proprinter XL Character Set menu, 239
 - LG, 240
 - PCL-II, 240
- Proprinter XL Emulation, 236
 - 20 CPI Condensed, 238
 - Alt. Char Set, 238
 - Auto LF, 237
 - Character Set, 237
 - Define CR Code, 236

- Define LF Code, 237
 - FF Valid at TOF, 237
 - Protect Configs., 83
 - PROTECTED INSTR * message, 338
 - PRT CONFIG key, 30
 - Prt Partial Line, 171, 182
 - 3270 Params menu, 189
 - 5250 Params menu, 198
 - Prt to Emulate, 164
 - P-Series Character Set menu, 225
 - LG, 227
 - PCL-II, 226
 - PSeries Dbl High, 224
 - P-Series Emulation, 219, 220, 221
 - Alt. Set 80-9F, 223
 - Auto LF, 222
 - Character Set, 224
 - Control Code 06, 221
 - Control Code 08, 221
 - Define CR Code, 222
 - Define LF Code, 222
 - FF Valid at TOF, 224
 - LG, 221
 - Overstrike, 222
 - PCL-II, 220
 - PSeries Dbl High, 224
 - P-Series SFCC, 223
 - SFCC d Command, 224
 - VFU Select, 223
 - P-Series SFCC, 78, 223
 - P-Series XQ Emulation, 228
 - Auto LF, 229
 - Compressed Print, 230
 - Control Code 06, 228
 - Define CR Code, 229
 - Define LF Code, 229
 - Elong/Alt. Font, 230
 - HS Print (High Speed Print), 230
 - Slew Relative, 231
 - Upr. Case Select, 231
 - VFU Select, 230
 - PTX Linefeed, PCL-II Emulation, 267
 - PTX Setup Option, MAINT/MISC menu, 282
 - PTX Transparent, 173, 183
 - 3270 Params menu, 190
 - 5250 Params menu, 198
 - Alt. Set 80-9F, 174, 183
 - Lead-in Chars, 173, 183
 - Usr Defined HTRN, 174, 183
 - PUM Default, ANSI Emulation menu, 256
 - Pwr Save Control, ADVANCED USER, 287
 - PWRSUPP VOLT * message, 338
- Q**
- QUEUE OVERRUN* message, 338
 - QUICK SETUP menu
 - Active IGP Emulation, 77
 - Adapter Address, 75
 - Device ID, 75
 - Ethernet Address, 76
 - Form Length, 77, 79
 - Form Width, 77, 79

Index

Horiz Forms, 80
Host Interface, 75
Margins, 78
Max Line Width, 80
Page Length Rep, 80
PGL SFCC, 77
Power-Up Config, 81
Printer Protocol, 77
P-Series SFCC, 78
Ribbon End Point, 80
Save Config, 81
Select CPI, 78
Select LPI, 78
Vert Forms, 79
WLAN Address, 76

R

RBN AT END POINT message, 339
RBN SENSOR ERROR message, 338
Ready, Dataproducts Parallel Interface Signals, 295
Receive Data (RD), RS-232, 305
Received CR, ANSI Emulation menu, 255
Received DEL, ANSI Emulation menu, 255
Reload paper, 34
REMOVE USED SPX message, 338
Renew Lifetime, WLAN Kerberos menu, 123
Report Status, Auto Switching submenu, 88
Request to Send
 RS-232, 305
 Serial submenu, 103

Requirements
 power, 21
 printer site, 22
Reset Cfg Names, 84
Reset Cmd CFG Ld, 218
 ANSI Emulation menu, 254
Reset Cmd CFG Ld, PCL-II Emulation, 268
Reset Kerberos Password, WLAN Kerberos menu, 122
Reset LEAP Password, WLAN LEAP menu, 124
Reset LEAP User, WLAN LEAP menu, 124
Resistor configurations, terminating, 302
Resistors
 installation, 303
 removal, 303
Resp. Polarity
 Centronics (Parallel) submenu, 92
 Dataproducts
 (Standard & Long Lines), 95
RESTORING BOOT CODE message, 338
RIB INVLD CMD* message, 338
RIB INVLD STATE* message, 339
Ribbon Action, PRINTER CONTROL, 288
RIBBON DRIVE message, 339
Ribbon End Point, 80
Ribbon End Point, PRINTER CONTROL, 277
Ribbon Flipping, 16
Ribbon Log, 16
RIBBON NOT RECOGNIZED message, 339

- RIBBON STALL message, 339
 - RIBBON UNDER 2% message, 339
 - Ribbons, changing, 49
 - Rot. Char Size, 156
 - RS-232, 305
 - Clear to Send (CTS), 306
 - Data Carrier Detect (DCD), 306
 - Data Set Ready (DSR), 306
 - Data Terminal Ready (DTR), 306
 - Receive Data (RD), 305
 - Request to Send (RTS), 305
 - Transmit Data (TD), 305
 - RS-232 Serial Interfaces, 304
 - RS-422, 306
 - RS-422 Serial Interfaces, 304
- S**
- Save Config, 81, 83
 - Save, Auto, 60
 - Saving new configurations, 61
 - Saving parameter settings, 54
 - Scalable Size, 142
 - SCS Buffer Cntrl, 173
 - SCS COMMAND ERROR message, 339
 - Second Char. Set, PCL-II Emulation, 265
 - SECURITY KEY NOT DETECTED message, 340
 - SECURITY VIOLATION message, 339
 - Select CPI, 78
 - Select Font, 134
 - Select LPI, 78, 135
 - Select SO Char, 138
 - SENDING PROGRAM TO EC PROCESSOR message, 340
 - Serial Interfaces
 - RS-232, 304
 - RS-422, 304
 - Serial Matrix Character Set menu, 235
 - Serial Matrix Emulation, 232
 - Alt. Set 80-9F, 234
 - Auto LF, 233
 - Character Set, 234
 - Control Code 06, 232
 - Define CR Code, 233
 - Define LF Code, 233
 - ESC d command, 234
 - Overstrike, 233
 - Printer Select, 234
 - Serial submenu, 98
 - Baud Rate, 102
 - Buffer Size in K, 104
 - Data Protocol, 99
 - Data Term Ready, 103
 - Framing Errors, 105
 - Idle Response, 104
 - Interface Type, 99
 - One Char Enquiry, 105
 - Parity, 102
 - Poll Character, 104
 - Poll Response, 104
 - Request to Send, 103
 - Stop Bits 1, 102
 - Word Length, 102

Index

- Set Lock Key, ADVANCED USER menu, 288
- Set Sharing, ADVANCED USER menu, 285
- Set Text Orientn, 174, 185
 - 3270 Params menu, 191
 - 5250 Params menu, 200
- SET TOF key, 30
- SFCC & Pwrap, 154
 - Power Up ^ F, 154
 - Power Up ^ PY, 154
 - Power Up ^ X, 154
 - VGL SFCC, 154
- SFCC Char, SPC Type, 207
- SFCC d Command, 224
- SHUTL INV CMD * message, 340
- SHUTL INV PARM * message, 340
- SHUTL OVR SPEED* message, 340
- SHUTTLE JAM message, 340
- SHUTTLE STALL message, 341
- Shuttle Timeout, ADVANCED USER menu, 286
- Signals
 - Centronics Parallel Interface, 297
 - Dataproducts Parallel Interface, 295
 - IEEE 1284 Parallel Interface, 299
- Simple Prot Conv, 168
- Site requirements, 22
- Skip Cmd Prefix, 135
- Slash 0, 134, 155
- Slew Relative, P-Series XQ Emulation, 231
- Slow Paper Slew, ADVANCED USER menu, 286
- SOFTWARE ERROR* CYCLE POWER message, 341
- SPC Char Set, SPC Type, 208
- SPC Coax Params, 202
 - Buffer Print, 203
 - Buffer Reprint, 204
 - Column 132 Wrap, 203
 - Image Buf Size, 202
 - Intervention Req, 203
 - Logical Buf Size, 202
 - NL At MPP+1, 205
 - PA1, 204
 - PA2, 204
 - SPC Null Supp, 204
 - SPC Space Supp, 205
 - Translation Tbl, 203
 - Usr Defined HTRN, 203
- SPC Null Supp, 204
- SPC Space Supp, 205
- SPC Twx Params, 206, 207
 - Buffer Print, 208
 - SPC Type, 207
 - Translation Tbl, 208
- SPC Type, 207
 - EVFU, 208
 - Printer Type, 207
 - SFCC Char, 207
 - SPC Char Set, 208
 - Usr Defined HTRN, 207
- Special information, 18

Specifications

- interfaces, 351
- label, 347
- paper, 346
- Speed print, 351
- SPX FOUND, ERROR KEY NOT DETECTED message, 341
- SPX NOT NEEDED OPTIONS ENABLED message, 341
- STACK FAULT message, 342
- STACK OVERFLOW* message, 341
- STACK UNDERFLOW* message, 341
- STACKER FULL message, 342
- STACKER JAM message, 342
- Standard, CTHI, 167
- Stop Bits 1, Serial submenu, 102
- Submenu
 - IGP/PGL, 129
 - IGP/PGL with LG, 132
 - IGP/PGL with PCL-II, 131
 - IGP/VGL, 148
 - IGP/VGL with LG, 152
 - IGP/VGL with PCL-II, 150
- Subnet mask
 - Adapter Address menu, 109
 - Ethernet Address menu, 114
 - WLAN Address menu, 118
- Support, technical, 20
- Symbol Set Print, PCL-II Emulation, 268
- System Memory, DIAGNOSTICS, 291

T

- TABLE MISMATCH DOWNLOAD AGAIN message, 342
- TCB CORRUPTED* message, 342
- TCP PORT BUSY message, 342
- Tear Bar Dist. (Distance), PRINTER CONTROL, 279
- Technical support, 20
- Terminating resistor configurations, 302
- Test Width, DIAGNOSTICS, 289
- Ticket Lifetime, WLAN Kerberos menu, 122
- Timeout, Auto Switching submenu, 88
- TOF Action
 - Centronics (Parallel) submenu, 93
 - Dataproducts (Standard & Long Lines) submenu, 96
 - IEEE 1284 Parallel (Bidirectional) Submenu, 89
- Translate Table, 178
- Translation Tbl, 171, 203
 - 3270 Params menu, 189
 - 5250 Params menu, 197
 - SPC Twx Params, 208
- Transmit Data (TD), RS-232, 305
- Trickle Time
 - Centronics (Parallel) submenu, 93
 - Dataproducts (Standard & Long Lines) submenu, 96
 - IEEE 1284 Parallel (Bidirectional) Submenu, 89
- Trickle Time, Auto Switching submenu, 87
- True Form Slew, 142

Index

True Vert 1/10, 156
Trunc Dyn Data, 143
Truncate Alpha, 155
Truncate PI Slew, ANSI Emulation menu, 256
Twinax Params menu, 180
 5225 World Trade, 182
 Active Char Set, 181
 Buffer Print, 186
 Cancel IGP/DCU, 182
 Char Set Select, 181
 Device Address, 182
 Device ID, 182
 Format Control, 186
 Graphic Chek Cod, 184
 Graphic Chek Err, 184
 Host Override, 185
 LAC Approx., 185
 LAC Option, 184
 Max. Print Width, 186
 Prt Partial Line, 182
 PTX Transparent, 183
 Set Text Orientn, 185

U

UNDEF INTERRUPT* message, 343
UNDFNED OP CODE* message, 343
Unidirectional, PRINTER CONTROL, 279
UNKNOWN RBN1 message, 343
UNKNOWN RBN2 message, 343
Unload paper, 45
Unsolicited Rpt, LG Emulation, 274
UP + DOWN key, 31

UP DRV. SHORT* message, 343
UP or DOWN key, 31
UPC Descenders, 137, 156
Upr. Case Select, P-Series XQ Emulation, 231
User-Def Ratio, 139
Usr Defined HTRN, 174, 203
Usr Defined HTRN, PTX Transparent, 183
Usr Defined HTRN, SPC Type, 207

V

Var Form Adjust, 139
Var Form Type, 140
Vert Forms, 79
Vert Forms, LG Emulation, 271
VFU Select, 223
VFU Select, P-Series XQ Emulation, 230
VGL SFCC, 154
VIEW/EJECT key, 29
Voltage, 350
VPA Check, IPDS Emulation, 262

W

WAITING FOR ETHERNET ADAPTER message, 343
Warnings, 18
Weight, printer, 348
Width Limit, 159
WLAN Address, 76
WLAN ADDRESS menu, 117
 DHCP, 118
 Gateway address, 118
 IP address, 117

- MAC address, 118
- Subnet mask, 118
- WLAN Kerberos menu
 - Clock Skew, 122
 - KDC Port Number, 122
 - Kerberos Enable, 121
 - Kerberos Password, 122
 - Renew Lifetime, 123
 - Reset Kerberos Password, 122
 - Ticket Lifetime, 122
- WLAN LEAP menu
 - Auth Method, 123
 - LEAP Password, 124
 - LEAP Username, 124
 - Reset LEAP Password, 124
 - Reset LEAP User, 124
- WLAN PARAMETERS menu
 - ASCII data port, 120
 - IPDS Data Port, 120
 - Keep alive timer, 120
 - NetBIOS protocol, 119
- WLAN PARAMS menu, 119
- Word Length, Serial submenu, 102



Index

**For technical assistance, contact your
Distributor/VAR/Reseller for service.**

For further assistance, contact the Printronix Customer Support Center.

Printronix Customer Support Center

Americas (714) 368-2686
Europe, Middle East, and Africa (31) 24 6489 410
Asia Pacific (65) 65484114
Web site: <http://www.primtronix.com/public/service/support/default.aspx>

Printronix Supplier Center

Americas (800) 733-1900
Europe, Middle East, and Africa (33) 1 46 25 1900
Asia Pacific (65) 65484116 or (65) 65484182
Web site: <http://www.primtronix.com/public/supplies/default.aspx>

Printronix, Inc.
14600 Myford Road
P.O. Box 19559
Irvine, CA92623-9559
Phone: 714-368-2300
Fax: 714-368-2600

Printronix Schweiz Gmbh
42 Changi South Street 1
Changi South Industrial
Estate Singapore 486763
Phone: 65-6542-0110
Fax: 65-6543-0220

Printronix, Inc.
Nederland BV
P.O. Box 163 Nieuweweg 283
NI-6600 Ad Wijchen
The Netherlands
Phone: 31-24-6489-489
Fax: 31-24-6489499

Or visit the Printronix web site at www.primtronix.com

